

034E WIND SENSOR OPERATION MANUAL



Met One Instruments, Inc

Corporate Sales & Service: 1600 NW Washington Blvd. Grants Pass, OR 97526

Tel (541) 471-7111 Fax (541) 471-7116

www.metone.com service@metone.com

Copyright Notice

© Copyright 2020 Met One Instruments, Inc. All Rights Reserved Worldwide. No part of this publication may be reproduced, transmitted, transcribed, stored in a retrieval system, or translated into any other language in any form by any means without the express written permission of Met One Instruments, Inc.

Technical Support

Should you require support, please consult your printed documentation to resolve your problem. If you are still experiencing difficulty, you may contact a Technical Service representative during normal business hours -7:00 a.m. to 4:00 p.m. Pacific Standard Time, Monday through Friday.

Voice: (541) 471-7111

Fax: (541) 471-7116

E-Mail: service@metone.com

Mail: Technical Services Department
Met One Instruments, Inc.
1600 NW Washington Blvd.
Grants Pass, OR 97526

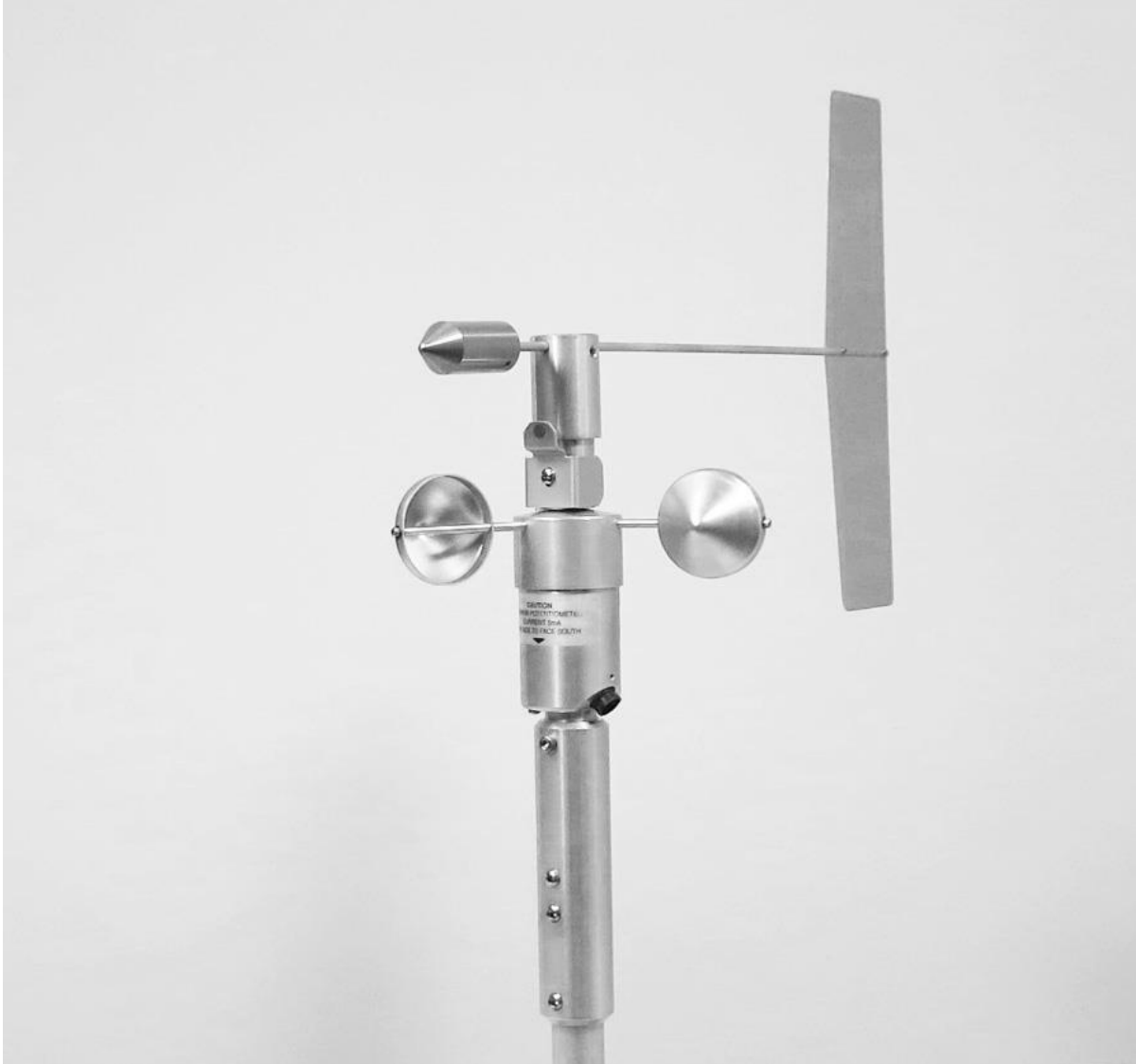

034E WIND SENSOR

1.0 GENERAL INFORMATION

- 1.1 The Met One Instruments Model 034E Wind Sensor consists of a wind speed sensor and wind direction sensor. The wind speed sensor uses a three cup anemometer to produce a series of contact closures in a magnetic reed switch. The frequency of the closures is proportional to wind speed. The wind direction sensor uses a balanced anodized aluminum vane assembly that changes the value of a linear potentiometer as the wind direction changes. The output of the potentiometer is proportional to the wind direction. A 1K ohm resistor in series with the wiper provides protection against overload situations.

1.2 SPECIFICATIONS

Wind Speed	
Range	0-167 MPH (0-269 kph, 0 - 75 m/s)
Starting Threshold	0.9 mph
Accuracy	
Less than 40 mph	+/- 0.40 mph (0.18 m/s)
Greater than 40 mph	+/- 1% of true
Wind Direction	
Range	Mechanical 0-360 Degrees Electrical 0-355 Degrees
Starting Threshold	0.9 mph
Accuracy	+/- 3 Degrees
Damping Ratio	0.25 Std.
Resolution	0.5 Degrees
Temperature Range	-50 Degrees C to +70 Degrees C, non-icing conditions
Weight	2 lb. 9 oz. With cable
Output signal	
Wind Speed	Pulsed contact closure Maximum current 5mA
Wind Direction	Potentiometer output (0-10K ohms) Maximum current 10mA Maximum open circuit voltage 28

2.0 INSTALLATION

NOTE: Save all sensor packaging. During future maintenance, it will be very handy for supporting the sensor and avoiding handling damage. Also, use during shipment for recommended factory servicing.

2.1 INSTALL VANE

- A. Insert the vane tail shaft into the hub. Make sure the shaft is fully seated at the bottom of its hole, which will replicate factory balance.
- B. Rotate the vane so that H aligns with the axis of the sensor body.
- C. Tighten the set screw using the 5/32" Allen wrench (provided) to secure the vane tail in the hub.

2.2 SENSOR INSTALLATION & ORIENTATION

- A. Install the sensor into the alignment adapter. The socket head screw will pass through the adapter and will tighten into the sensor housing.
- B. Place the sensor with adapter onto top of the tripod mast or in the fitting on the cross arm.
- C. Rotate the entire sensor until the vane points to "TRUE NORTH". The use of transit/compass will assure accurate alignment when the magnetic correction to true has been established.
- D. When the sensor is properly aligned, tighten the adapter set screw using the 5/32" Allen wrench. By removing the socket head screw in the adapter, the sensor may be removed and replaced without realignment.
- E. Remove and retain the alignment adaptor and screw from the vane hub. Check to see that the vane assembly rotates freely.
- F. Connect the cable to the sensor. Route the cable to the data recording device. Secure the cable with cable ties or tape. The cable assembly contains 5 wires. Typical wiring hookup shown in section 2.3.

2.3 CABLE WIRING

Wind Sensor 3013 Cable Wiring:

RED	Wind Speed Signal
BLK	Wind Speed Common
WHT	Wind Direction Reference
GRN	Wind Direction Common
YEL (or BLU or ORG)	Wind Direction Signal

2.4 LIGHTNING PROTECTION

Weather sensors are sensitive to direct or nearby lightning strikes. A well-grounded metal rod or frame should be placed above the sensor installation. In addition, the shield on the signal cable leading to the translator must be connected to a good earth ground at the translator end. The cable route should not be vulnerable to lightning.

3.0 OPERATIONAL CHECK-OUT AND CALIBRATION

3.1 Wind Speed and Direction Sensor Check-Out

- A. Rotating the vane in a clockwise direction as viewed from above will increase the output up to the 360 Degree point and it will start over at 0 Degrees.
- B. Spinning the anemometer cup assembly will produce a series of pulses. To verify sensor output, monitor this signal with either a translator module, data logger or an ohmmeter. Refer to Frequency vs. Wind Speed Table 3-1. Spin slowly and monitor output signal. A wind speed calibrator may be used to check operation at different RPM points. The vane and counterweight must both be removed for connection to the calibrator motor drive.
- C. The 034E wind sensor should be inspected periodically for physical damage to the vane assembly and cable connections. Inspect all vane assembly parts for security and damage. Inspect the cup assembly for loose cup arms or other damage. The cup assembly will affect calibration if a mechanical part has loosened or has been bent or broken.

TABLE 3-1

MODEL 034E WIND SPEED SENSOR CALIBRATION

WIND VELOCITY VS OUTPUT FREQUENCY

CALIBRATION EQUATIONS

$$V \text{ mph} = \frac{\text{RPM}}{16.787} + 0.63$$

$$V \text{ mps} = \frac{\text{RPM}}{37.547} + 0.28$$

$$V \text{ mph} = \frac{\text{FHZ}}{0.5596} + 0.63$$

$$V \text{ mps} = \frac{\text{FHZ}}{1.2517} + 0.28$$

SPEED IN MILES/HR		
V (mph)	RPS	F Hz
10.00	2.62	5.24
20.00	5.42	10.84
30.00	8.22	16.43
40.00	11.02	22.03
50.00	13.81	27.63
60.00	16.61	33.22
70.00	19.41	38.82
80.00	22.21	44.41
90.00	25.00	50.01
100.00	27.80	55.60
110.00	30.60	61.20
120.00	33.40	66.80
130.00	36.20	72.39
140.00	38.99	77.99
150.00	41.79	83.58
160.00	44.59	89.18
170.00	47.39	94.77

SPEED IN METERS PER SECOND		
V (mps)	RPS	F Hz
2.50	1.39	2.78
5.00	2.95	5.91
7.50	4.52	9.04
10.00	6.08	12.17
12.50	7.65	15.29
15.00	9.21	18.42
17.50	10.78	21.55
20.00	12.34	24.68
22.50	13.90	27.81
25.00	15.47	30.94
27.50	17.03	34.07
30.00	18.60	37.20
32.50	20.16	40.33
35.00	21.73	43.45
37.50	23.29	46.58
40.00	24.86	49.71
42.50	26.42	52.84
45.00	27.99	55.97
47.50	29.55	59.10
50.00	31.11	62.23
52.50	32.68	65.36
55.00	34.24	68.49
57.50	35.81	71.61
60.00	37.37	74.74
62.50	38.94	77.87
65.00	40.50	81.00
67.50	42.07	84.13
70.00	43.63	87.26
72.50	45.19	90.39
75.00	46.76	93.52

RPM VS WIND SPEED

RPM	MPS	MPH	F Hz
100.00	2.94	6.59	3.33
200.00	5.61	12.54	6.67
300.00	8.27	18.50	10.00
400.00	10.93	24.46	13.33
500.00	13.60	30.41	16.67
600.00	16.26	36.37	20.00
700.00	18.92	42.33	23.33
800.00	21.59	48.29	26.67
900.00	24.25	54.24	30.00
1000.00	26.91	60.20	33.34
1100.00	29.58	66.16	36.67
1200.00	32.24	72.11	40.00
1300.00	34.90	78.07	43.34
1400.00	37.57	84.03	46.67
1500.00	40.23	89.98	50.00
1600.00	42.89	95.94	53.34
1700.00	45.56	101.90	56.67
1800.00	48.22	107.86	60.00
1900.00	50.88	113.81	63.34
2000.00	53.55	119.77	66.67
2100.00	56.21	125.73	70.00
2200.00	58.87	131.68	73.34
2300.00	61.54	137.64	76.67
2400.00	64.20	143.60	80.00
2500.00	66.86	149.55	83.34
2600.00	69.53	155.51	86.67
2700.00	72.19	161.47	90.01
2800.00	74.85	167.43	93.34

4.0 MAINTENANCE AND TROUBLESHOOTING

4.1 General Maintenance Schedule

6-12 month intervals:

- A. Inspect the sensor for proper operation per Section 3.0
- B. Replacement of Wind Speed Sensor bearing in extremely adverse environments.

12-24 month intervals:

- A. Replacement of Wind Speed Sensor bearings.

24-36 month intervals:

- A. Recommended complete factory overhaul of sensor.

*Schedule is based on average to adverse environments.

TABLE 4.1

TROUBLESHOOTING TABLE

<u>Symptom</u>	<u>Probable Cause</u>	<u>Remedy</u>
No WS Sensor output	Faulty bearings	Replace bearings (REF. 4.2)
No WD Sensor output	Faulty pot assembly	Replace pot assy. (REF 4.3)
No WS Sensor output	Faulty reed switch	Replace reed switch (REF 4.4)
No WS or WD output	Faulty cable	Check cable and connections

4.2 Wind speed bearing replacement

- A. Refer to Figure 4-1. Remove sensor housing clamping screw (Item 16). Slide the sensor housing (Item 6) open 1 ½” to 2”, exposing the internal terminal blocks.



- B. Refer to figure 4-2. With small flat bladed screwdriver, loosen the three wire contacts of the white, green, & yellow wires in positions 3, 4 and 5 of the J1 terminal block, going to the wind direction potentiometer. Gently pull the wires free from the terminal block and straighten them enough to allow easy passage through the stem on the top of sensor.

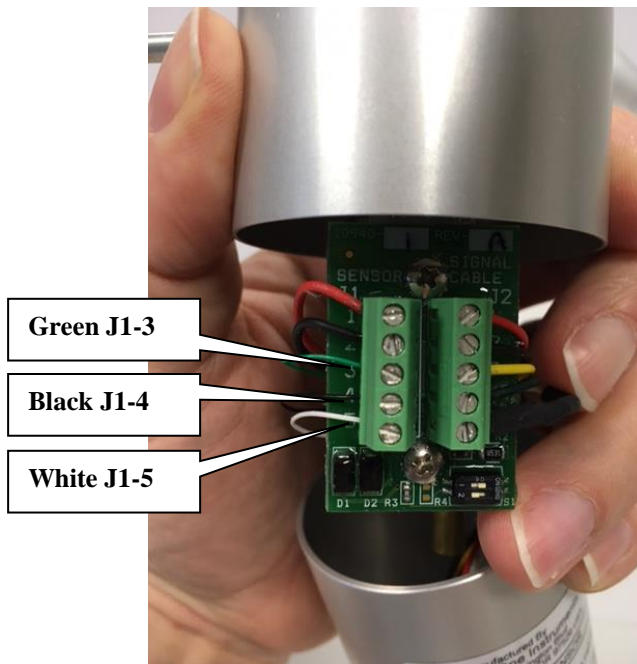

- C. Slide sensor housing closed. A notch in the tip rim of the sensor housing must engage with the “South” pin located on the outer edge of the Top Plate Assembly to allow proper closure. Install the screw.
- D. Refer to Figure 4-3. To facilitate maintenance and to minimize the risk of damage, support the sensor upright in the foam packing as shipped or some other method.

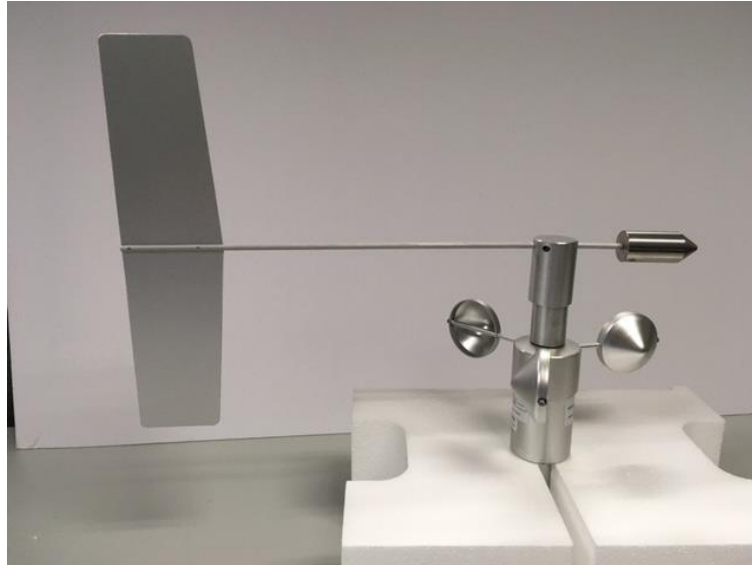
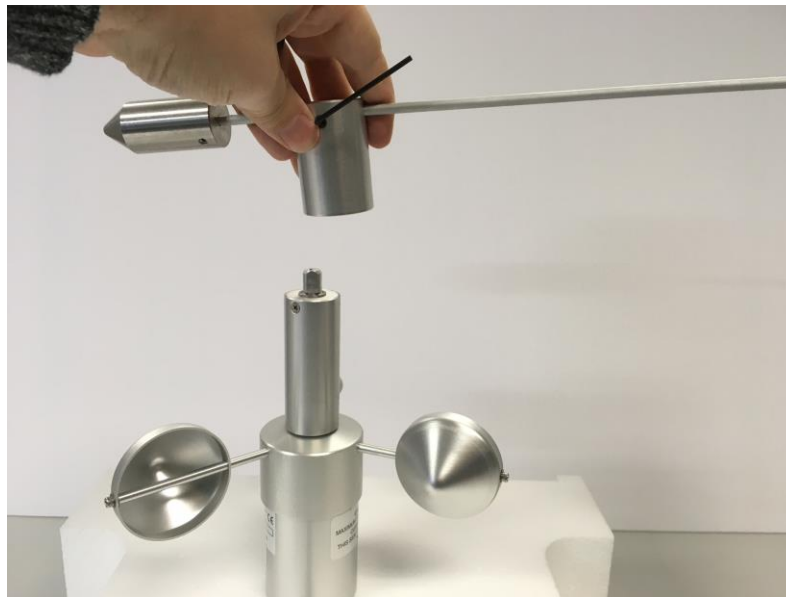

FIGURE 4-3

- D. Remove the alignment adaptor and screw if installed.



- E. Remove the wind direction vane if installed. Using a 5/64" allen wrench, loosen the center hub set screw 1 to 2 turns, and lift the vane up and off.



- F. With the 5/64" Allen wrench (Item 20). Loosen by only a ¼ turn, the set screw located in the side of the wind vane hub. The ¼ turn loosening will enable easier alignment of the pot/mount assembly during the re-assembly process.



- G. Carefully remove entire vane/potentiometer assembly from body of sensor. Use care to avoid snags when withdrawing the wires from the top stem.



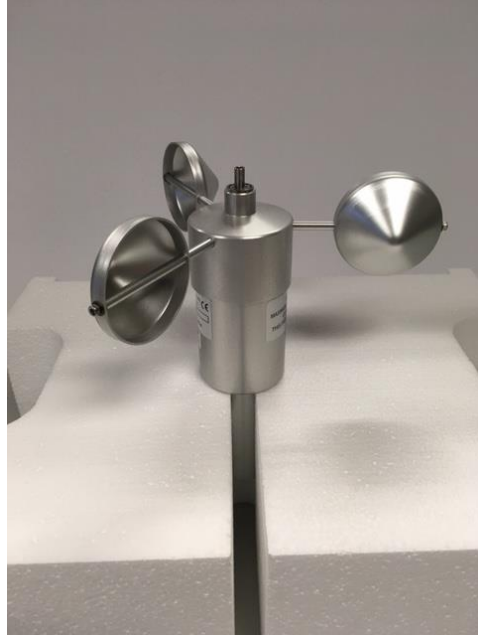

- H. Remove cup assembly (Item 2). Remove the old bearings. Clean areas of bearing contact using a cotton swab and alcohol.



CUP ASSEMBLY AND BEARINGS

CAUTION: DO NOT LUBRICATE OR FORCE BEARINGS

- I. Install new bearings (Item 12) and cup assembly (Item 2) onto stem.

NOTE: If potentiometer needs replacement, now refer to Section 4-3.

NOTE: If reed switch needs replacement, now refer to Section 4-4.

- J. Refer to Figure 4-2. Feed Pot/Mount Assembly wires into center hold in sensor stem. Note the location of the flat on the sensor stem as re-alignment of the Pot/Mount Assembly is critical to re-establish factory calibration.

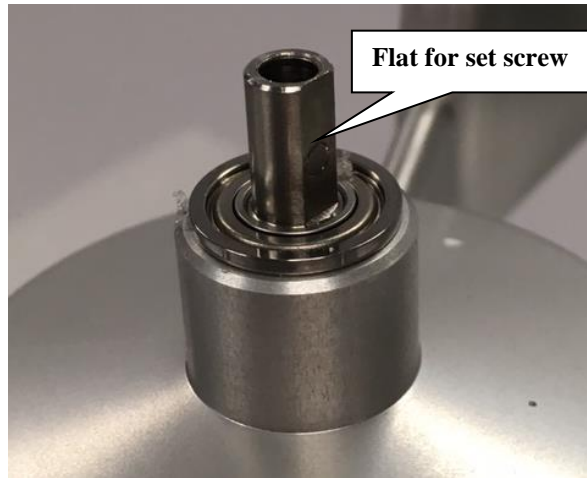

- K. Seat the unit onto the sensor stem and slowly tighten the set screw as you feel that the flat alignment has been accomplished.
- L. Spin the Cup Assembly to check for freedom of rotation. There should be a small amount of up and down play (Approximately .010").
- M. Re-open sensor body; connect pot wires in terminal block, matching wire colors as in Step B.
- N. Prior to final closure of sensor body, inspect inside. Ensure that wires are routed as to prevent pinching or over-straining. Make sure wires do not get between spacer and interior of sensor body. Close sensor and secure with screw.
- O. Unit is now ready for service.

4.3 Wind Direction Potentiometer Replacement

- A. Follow Steps A through G in Section 4.2
- B. Replace old, removed potentiometer assembly (item 3) with new.
- C. Follow Steps J through O in Section 4.2 to install new Pot/Mount Assembly.
- D. Slip Vane Hub onto pot shaft and adaptor, aligning the flat with the set screw in the upper side of the vane hub. Tighten the set screw. Reinstall alignment adaptor and screw as seen in Step D.
- E. Refer to Figure 4-5. Connect an ohmmeter to pins 3 and 4 of the cable connector (Item 9) mounted on the lower side of the sensor housing.
- F. The resistance measured across pins 3 and 4 should be approximately equal to the resistance measured across pins 3 and 5 (approx. 6k ohms).
- G. Remove shoulder screw. Rotate vane assembly clockwise $\frac{1}{4}$ turn as viewed from above. Check that the resistance between pins 3 and 4 is 8.5k ohms
- H. Unit is now ready for service.

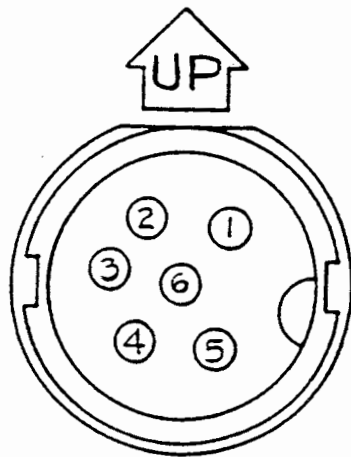
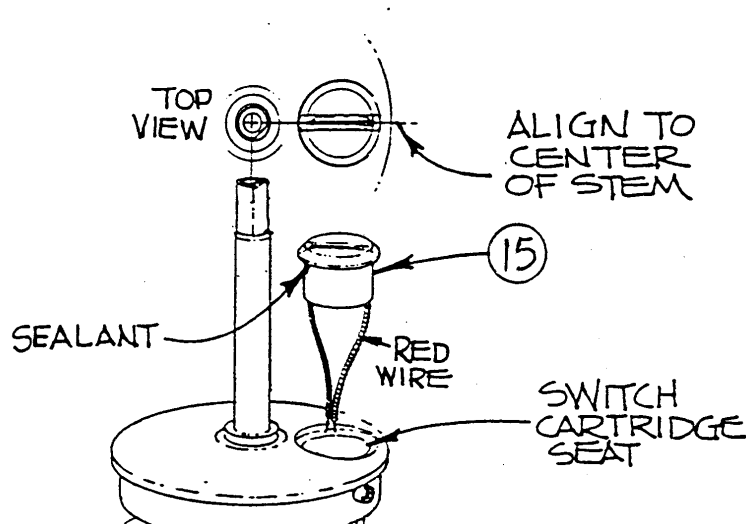

FIGURE 4-5
SENSOR CONNECTOR PIN LAYOUT

4.4 Wind Speed Reed Switch Cartridge Replacement

- A. Follow Steps A through H in Section 4-2.
- B. Open the sensor housing.
- C. From the terminal block circuit board, disconnect the black and red wires coming from the Reed Switch Cartridge (item 15) from locations J1-1 and J1-2.
- D. Push switch cartridge out of its seat. Clean off any old sealant from the Top Plate Assembly.
- E. Refer to Figure 4-6. Apply a small bead of RTV silicone sealant under cartridge flange. Noting proper orientation, push into hole.
- F. Wipe away excess sealant. Allow for overnight curing before reassembly.
- G. Using care to avoid stressing switch leads while routing, connect the switch wires in the terminal strip. Match wire colors with sensor connector harness. Refer to Figure 4-2.
- H. Follow steps J through O in Section 4.2.



4.5 Vane Assembly Replacement and Balance Procedure

Vanes and counterweight are matched and balanced at the factory, but if customer vane replacement is performed, the balance of the assembly must be verified prior to returning the sensor to service.

- A. To install replacement vane...
1. Insert the vane tail shaft into the hub. Make sure the shaft is fully seated at the bottom of its hole.
 2. Rotate vane to align axis to sensor body and tighten set screw to secure vane assembly.

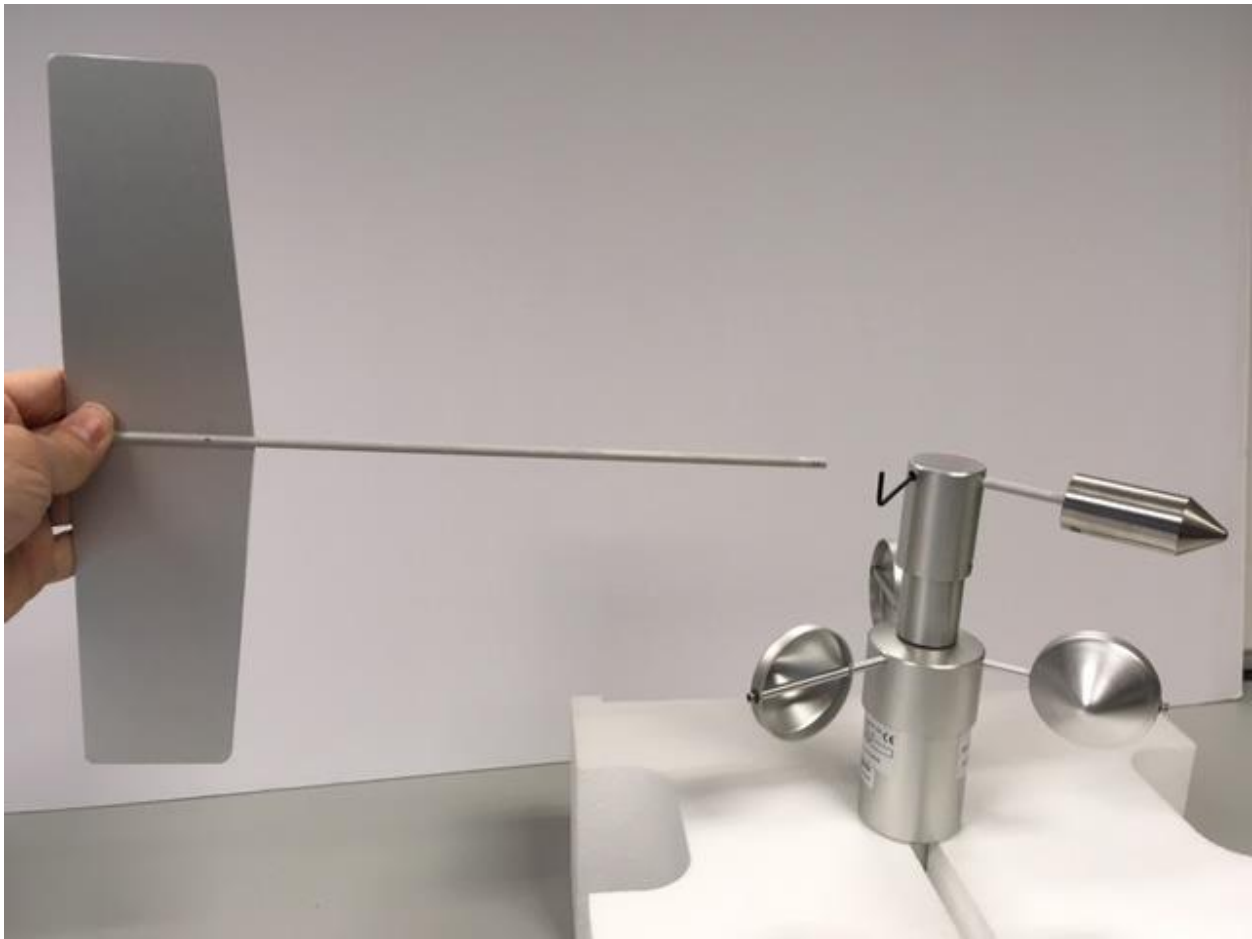

B. To prove proper vane assembly balance...

1. Hold or clamp sensor so that its axis is horizontal. Make sure the orientation shoulder is removed from the hub.
2. Rotate the vane shaft to level and gently release. If vane and counterweight remain level, assembly is already in proper balance and no further adjustment is required.
3. If balancing is required, loosen both counterweight set screws (using a 5/64" hex key) and move the counterweight on the shaft as required to establish balance. Do NOT remove the shaft from the hub.

NOTE: Position the counterweight on the stem so that the set screw holes face towards the sensor base. This will prevent moisture from collecting in the screw holes during sensor operation.

4. Tighten the set screws and recheck balance. Readjust as required and return the sensor to service.

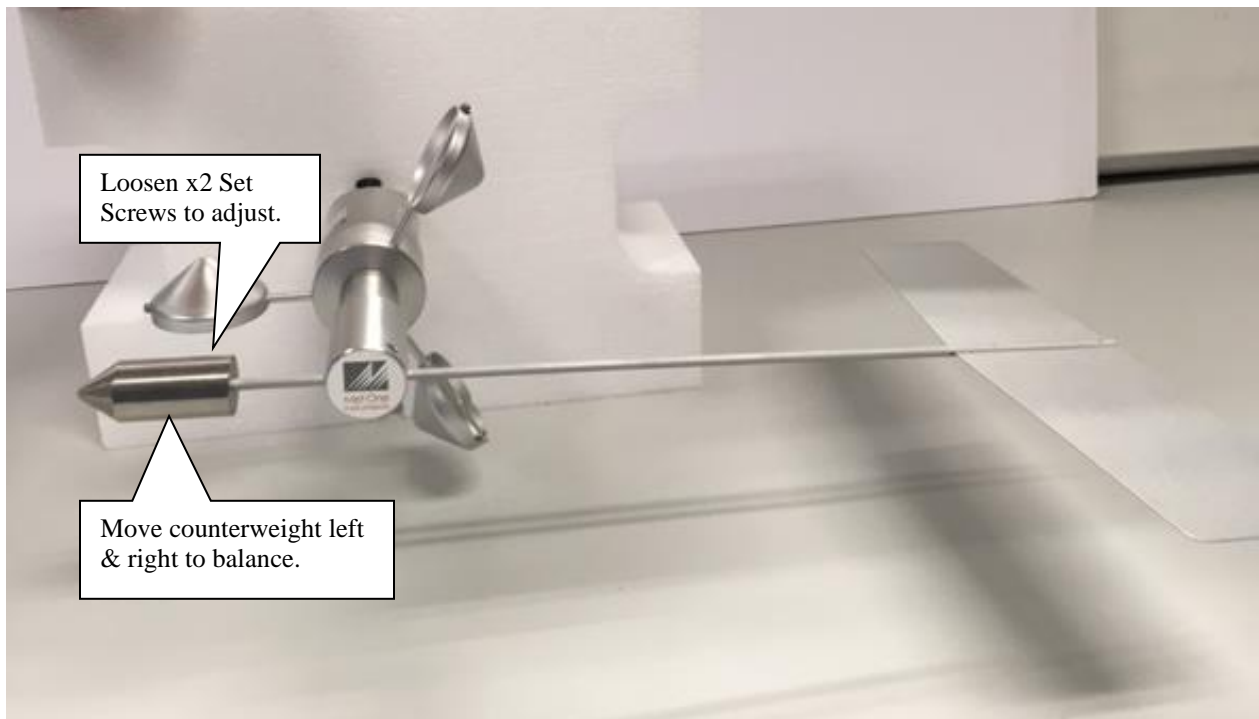
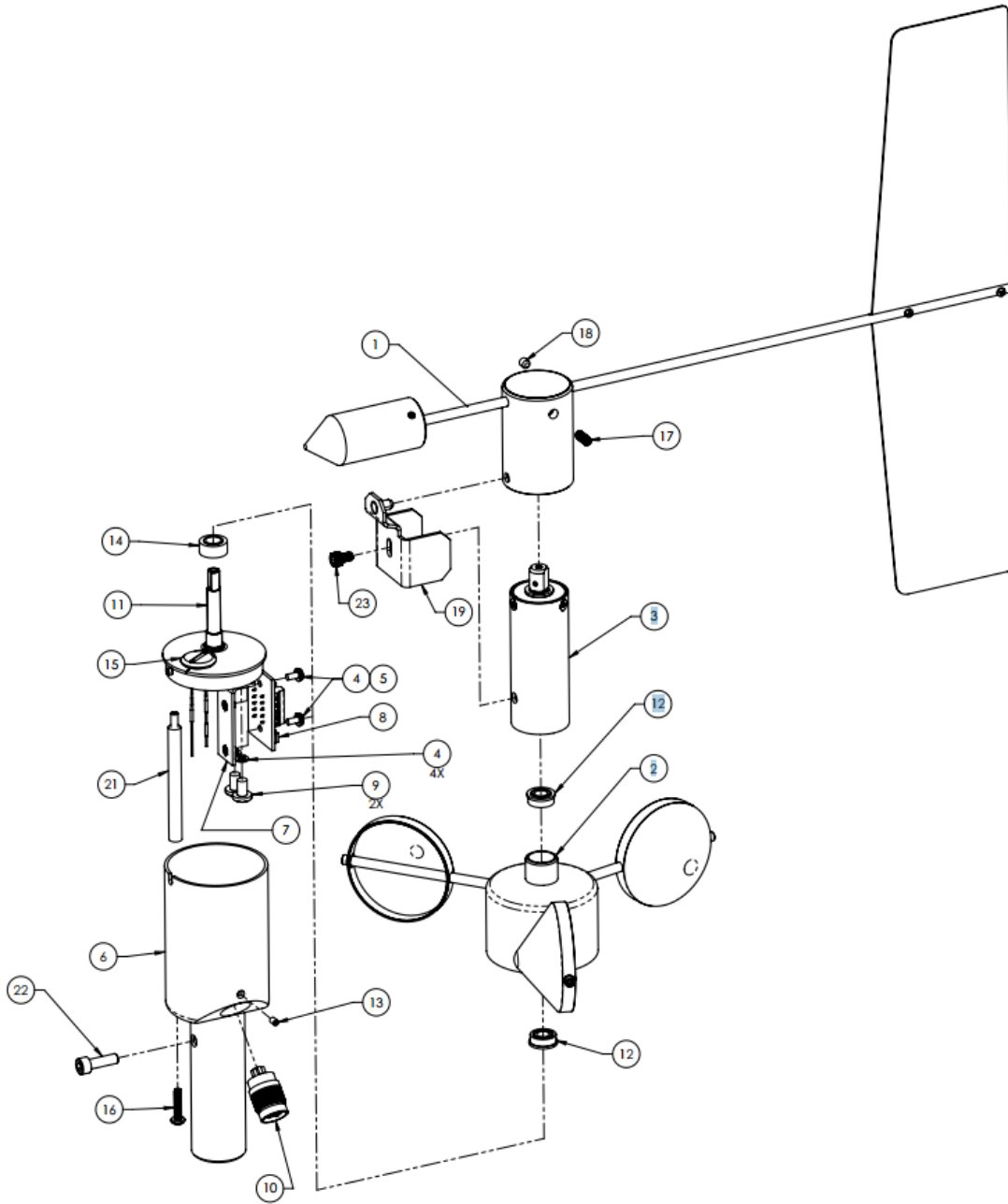

FIGURE 4-7
EXPLODED PARTS VIEW OF 034E



REPLACEMENT PARTS LIST (REFER TO FIGURE 4-7)

ITEM NO.	PART NO.	DESCRIPTION
1	3387	VANE ASSEMBLY
2	10986	CUP ASSEMBLY
3	3786-1	POT MOUNT ASSEMBLY
4	602340	WASHER, SPLIT, #6
5	601480	SCREW, PAN HD, 6/32 X 1/4"
6	3019	SENSOR HOUSING MOUNT
7	3092-1	BRACKET, TERMINAL BLOCK
8	10940-1	TERMINAL BLOCK, PCBA
9	601550	SCREW, 6-32, x 3/8, PAN HD
10	10634	CONNECTOR WIRING ASSEMBLY
11	3369	TOP PLATE STEM ASSEMBLY
12	1898	BEARING
13	601254	SET SCREW, 4-40 x 3/16, CUP PT.
14	3366	SPACER SLEEVE
15	6838	REED SWITCH ASSY
16	601580	SCREW, 6-32x5/8 PAN HD
17	601645	SET SCREW, 8-32 x 3/8, BRASS TIP
18	601650	SET SCREW, 8-32 x 3/16
19	10969	WD ALIGNMENT JIG, 034E
20	993000	ALLEN WRENCH 5/64
21	3368	SPACER, BRASS
22	601850	SCREW, 10/32 x 5/8 SOC CAP