

USER MANUAL

Serinus Cal 1000, 2000 & 3000

Dilution Calibrator

Version: 4.1

This page is intentionally blank.

Table of Contents

Table of Contents.....	3
List of Figures	7
List of Tables.....	10
List of Appendices	12
Manufacturer’s Statement	13
Safety Information	14
Important Safety Messages	15
Warranty.....	16
Service and Repairs.....	17
Service Guidelines	17
Product Compliance and Approvals.....	18
Manual Revision History	19
1. Introduction.....	21
1.1 Description	21
1.2 Specifications	21
1.2.1 Dilution & Span Flows.....	21
1.2.2 Power.....	22
1.2.3 Operating Conditions.....	22
1.2.4 Communications.....	22
1.2.5 Physical Dimension	23
1.2.6 Ozone Generator [Serinus Cal 2000]	23
1.2.7 Photometer [Serinus Cal 3000].....	24
1.3 Nomenclature	24
1.4 Background/Theory.....	25
1.4.1 Dilution Theory	25
1.4.2 Ozone Photometer Theory [Serinus Cal 3000]	26
1.4.3 Explanation Photometer Transfer Standards.....	27
1.5 Instrument Description	28
1.5.1 Common Components.....	28
1.5.2 Serinus Cal 1000 Components	35
1.5.3 Serinus Cal 2000 Components	36
1.5.4 Serinus Cal 3000 Components	38
2. Installation.....	45
2.1 Initial Check.....	45
2.2 Installation Notes	48
2.3 Instrument Set-up	48
2.3.1 Setting-up a Serinus Cal	49
2.3.2 Setting-up a Serinus Cal 3000	50
2.3.3 Power Connections.....	51
2.3.4 Pneumatic Connections	52
2.3.5 Fitting Procedure	53
2.3.6 Diluent Gas	55
2.3.7 Source Gas	55
2.3.8 Output Ports	55
2.3.9 Exhaust Port.....	56
2.3.10 Purge for Gas Lines	56
2.3.11 Communications Connections	56

2.4	Transporting/Storage.....	56
3.	Operation.....	59
3.1	Warm-Up.....	59
3.2	Theory of Operation	59
3.2.1	Running a Point or Sequence	60
3.2.2	Operation	60
3.3	General Operation Information	74
3.3.1	Keypad & Display.....	74
3.4	Home Screen	76
3.5	Menus & Screens	78
3.5.1	Quick Menu	79
3.5.2	Main Menu.....	81
3.5.3	Gas Supply Menu	81
3.5.4	Edit Gas Standards Menu	82
3.5.5	Edit Gas Standard Menu.....	83
3.5.6	Edit Custom Gasses Menu.....	84
3.5.7	Edit Custom Gas Menu.....	84
3.5.8	Points & Sequencing Menu	85
3.5.9	Define Points Menu.....	85
3.5.10	Define Point Menu	86
3.5.11	Define Sequences Menu	89
3.5.12	Define Sequence Menu	90
3.5.13	Manual Operation Menu.....	91
3.5.14	Manual Point Menu	92
3.5.15	Manual Flow Menu	92
3.5.16	Analyser State Menu	93
3.5.17	Status Menu	94
3.5.18	Temperature Menu	96
3.5.19	Pressure & Flow Menu	97
3.5.20	Voltage Menu.....	98
3.5.21	General Settings Menu.....	99
3.5.22	Measurement Settings Menu.....	100
3.5.23	Calibration Menu	100
3.5.24	Pressure Calibration Menu.....	101
3.5.25	Ozone Calibration Menu	102
3.5.26	MFC Calibration Menu	103
3.5.27	Service Menu.....	104
3.5.28	Diagnostics Menu.....	105
3.5.29	Digital Pots Menu	105
3.5.30	Internal Pump Menu	107
3.5.31	Valve Menu	108
3.5.32	Tests Menu.....	109
3.5.33	Digital Input Test Menu.....	110
3.5.34	Digital Output Test Menu.....	110
3.5.35	Calculation Factors Menu.....	111
3.5.36	Communications Menu	112
3.5.37	Data Logging Menu	112
3.5.38	Serial Communication Menu.....	113
3.5.39	Analog Input Menu	114
3.5.40	Analog Output Menu.....	115
3.5.41	Digital Output Menu	116
3.5.42	Network Menu (Optional).....	118

3.5.43	Bluetooth Menu (Optional)	119
3.5.44	Trend Display Menu.....	120
3.5.45	Chart.....	120
3.5.46	Advanced Menu.....	122
3.5.47	Hardware Menu.....	123
3.5.48	MFC Installation Menu	124
3.5.49	Parameter Display Menu	125
4.	Communications.....	127
4.1	RS232 Communication	127
4.2	USB Communication.....	128
4.3	TCP/IP Network Communication (Optional)	129
4.3.1	Reading Network Port Setup	130
4.3.2	Setting Network Port Setup	130
4.3.3	Port Forwarding on Remote Modem/Router Setup	131
4.3.4	Setup Airodis to Communicate with Serinus	131
4.4	Analog/Digital Communication	132
4.4.1	Analog Outputs	133
4.4.2	Analog Inputs.....	133
4.4.3	Digital Status Inputs.....	134
4.4.4	Digital Status Outputs.....	134
4.5	Diluent Control.....	135
4.6	Logging Data.....	135
4.6.1	Configure Instrument Internal Logging.....	135
4.7	Using Airodis Software to Download Data	136
4.7.1	Connecting the Serinus to a PC.....	136
4.7.2	Installing Airodis	139
4.7.3	Configuring Airodis	139
4.8	Serinus Remote App/Bluetooth	144
4.8.1	Installation	145
4.8.2	Connecting to the Instrument	145
4.8.3	Control Serinus Instrument.....	146
4.8.4	Real-Time Plot.....	148
4.8.5	Download.....	149
4.8.6	Get Parameters.....	149
4.8.7	Preferences.....	150
5.	Calibration.....	153
5.1	MFC Calibration.....	153
5.1.1	MFC Pre Calibration Setup.....	154
5.1.2	MFC Calibration	155
5.1.3	Readout Calibration	155
5.2	Ozone Flow Calibration	156
5.3	Pressure Calibration	157
5.3.1	Full Pressure Calibration (Two Point Calibration)	157
5.3.2	Pressure Calibration (Ambient Only)	159
5.4	Ozone Generator Characterisation - Serinus Cal 2000	159
5.5	Ozone Generator Characterisation - Serinus Cal 3000	160
5.6	Photometer Calibration - Serinus Cal 3000	161
5.6.1	Photometer Pre Check.....	161
5.6.2	Photometer Calibration	162
5.7	Photometer Audit With External Ozone Source.....	163

6. Service.....	167
6.1 Additional Safety Requirements for Service Personnel	167
6.2 Maintenance Tools	167
6.3 Maintenance Schedule	168
6.4 Maintenance Procedures.....	169
6.4.1 Leak Check Serinus Cal 3000	169
6.4.2 UV Lamp Check Serinus Cal 3000	174
6.4.3 Cleaning.....	175
6.4.4 MFC zero flow voltage check and adjustment	175
6.5 Bootloader	178
6.5.1 Display Help Screen.....	178
6.5.2 Communications Port Test	178
6.5.3 Updating Firmware from USB Memory Stick	178
6.5.4 Erase All Settings	179
6.5.5 Start Calibrator	179
7. Troubleshooting.....	181
7.1 Main Screen Error Messages	181
7.2 Technical Support Files	181
7.3 USB Memory Stick Failure.....	183
7.4 Lamp Temperature Failure	184
8. Optional Extras.....	185
8.1 Rack Mount Kit (PN: E020116).....	185
8.2 Network Port (PN: E020317).....	189
8.2.1 Hardware Setup	189
8.3 Metric Fittings Kit (PN: E020122).....	190
8.4 Additional Source Ports (PN: E020314)	190
8.4.1 Hardware Setup	190
8.5 Additional Diluent Port (PN: E020315)	191
8.5.1 Hardware Setup	191
8.6 Second Source MFC (PN: E020318-XX)	192
8.6.1 Hardware Setup	193
8.7 Second Diluent MFC (PN: E020316-XX)	193
8.7.1 Hardware Setup	194
9. Spare Parts and Schematics.....	195
9.1 Maintenance Kit (PN: E020321, E020322, E020323)	195
9.2 Serinus Cal Service Kit (PN: E020320)	195
9.3 Consumables	196
9.4 Instrument Parts List.....	197
9.5 Plumbing Schematic (Serinus Cal 1000) - (PN: D020034)	202
9.6 Plumbing Schematic (Serinus Cal 2000) - (PN: D020035)	203
9.7 Plumbing Schematic (Serinus Cal 3000) - (PN: D020036)	204
9.8 Block Wiring Schematic (Serinus Cal 1000) - (PN: D020037)	205
9.9 Block Wiring Schematic (Serinus Cal 2000) - (PN: D020038)	206
9.10 Block Wiring Schematic (Serinus Cal 3000) - (PN: D020039)	207
9.11 Valve Manifold - (PN: H013180-01)	208
9.12 Mixing Manifold (Serinus Cal 3000) - (PN: H013185).....	209

9.13	Mixing Manifold (Serinus Cal 2000) - (PN: H013185-01).....	210
9.14	Photometer (Serinus Cal 3000) - (PN: H013100-01).....	212
9.15	Bullet Valve - (PN: H010058).....	213

List of Figures

Figure 1 – Dilution Theory for Serinus Cal.....	26
Figure 2 – Ozone Transfer Standard Hierarchy.....	27
Figure 3 – Solenoid Bullet Valve.....	30
Figure 4 – Solenoid Bullet Valve Operation.....	30
Figure 5 – Differential Pressure Sensor PCA.....	31
Figure 6 – Power ON/OFF Switch.....	31
Figure 7 – Acoem Tubing.....	33
Figure 8 – Communication Connections.....	33
Figure 9 – Major Components of Serinus Cal 1000.....	35
Figure 10 – Major Components of Serinus Cal 2000.....	36
Figure 11 – Ozone Generator Assembly.....	37
Figure 12 – Mixing Manifold Serinus Cal 2000.....	38
Figure 13 – Major Components of Serinus Cal 3000.....	39
Figure 14 – Mixing Manifold Serinus 3000.....	39
Figure 15 – Flow Block Assembly.....	40
Figure 16 – Photometer Assembly.....	41
Figure 17 – Orifice and Sintered Filter.....	41
Figure 18 – Lamp Driver PCA Type Jumper Setting (REV D).....	42
Figure 19 – Ozone Scrubber.....	43
Figure 20 – Received Items.....	46
Figure 21 – Opening the Instrument - 1.....	47
Figure 22 – Opening the Instrument - 2.....	47
Figure 23 – Opening the Instrument - 3.....	47
Figure 24 – Opening the Instrument - 4.....	48
Figure 25 – Serinus Cal Rear Panel.....	49
Figure 26 – Installation of USB Memory Stick.....	49
Figure 27 – Switching the Battery ON/OFF.....	50
Figure 28 – Connecting the Output and Exhaust Ports Serinus Cal 3000 Only.....	50
Figure 29 – Connect Power Cord.....	52
Figure 30 – Turn ON Power Switch.....	52
Figure 31 – Dust Plugs.....	53
Figure 32 – Remove Nut.....	53
Figure 33 – Ferrule Correct Position.....	53
Figure 34 – Tighten Nut with Finger.....	54
Figure 35 – Ferrule Correct Position.....	54
Figure 36 – Tighten Kynar Nut with Finger.....	54
Figure 37 – Dust Plugs.....	57
Figure 38 – Packing Instruction.....	58
Figure 39 – Edit Gas Standard Menu (Example 1).....	61
Figure 40 – Gas Supply Menu (Example 1).....	61
Figure 41 – Gas Dilution Point Setup (Example 1).....	62
Figure 42 – Home Screen Running EXE 01 Point.....	62
Figure 43 – Zero Point Setup.....	63
Figure 44 – Home Screen Running EXE 02 Point.....	64
Figure 45 – Edit Gas Standard Menu (Example 3).....	65
Figure 46 – Source Control Setup.....	65

Figure 47 – Home Screen Running EXE 03 Point.....	66
Figure 48 – Edit Gas Standard Menu (Example 4)	67
Figure 49 – Gas Supply Menu (Example 4)	67
Figure 50 – Titration Setup, with Ozone.....	68
Figure 51 – Home Screen Running EXE 04 Point.....	68
Figure 52 – Titration Setup, without Ozone	69
Figure 53 – Home Screen Running EXE 05 Point.....	69
Figure 54 – O3 Generator Setup.....	70
Figure 55 – Home Screen Running EXE 06 Point.....	71
Figure 56 – O3 Gen/Photometer Setup	72
Figure 57 – Home Screen Running EXE 07 Point.....	72
Figure 58 – Titration Sequence Setup.....	73
Figure 59 – Home Screen Running GPT 1 Sequence	73
Figure 60 – Front Panel.....	74
Figure 61 – Home Screen.....	76
Figure 62 – Quick Menu Screen.....	79
Figure 63 – Mode Screen.....	80
Figure 64 – Main Menu Screen.....	81
Figure 65 – Gas Supply Menu Screen	81
Figure 66 – Edit Gas Standards Menu Screen	83
Figure 67 – Edit Gas Standard Menu Screen	83
Figure 68 – Edit Custom Gasses Menu Screen.....	84
Figure 69 – Edit Custom Gas Menu Screen.....	84
Figure 70 – Edit Custom Gasses Menu Screen.....	85
Figure 71 – Define Points Menu Screen.....	85
Figure 72 – Define Point Menu Screen	86
Figure 73 – Define Sequences Menu Screen	89
Figure 74 – Define Sequence Menu Screen.....	90
Figure 75 – Manual Operation Menu Screen.....	91
Figure 76 – Manual Point Menu Screen	92
Figure 77 – Manual Flow Menu Screen	93
Figure 78 – Analyser State Menu Screen.....	93
Figure 79 – Status Menu Screen.....	94
Figure 80 – Temperature Menu Screen.....	96
Figure 81 – Pressure & Flow Menu Screen.....	97
Figure 82 – Voltage Menu Screen.....	98
Figure 83 – General Settings Menu Screen.....	99
Figure 84 – Measurement Settings Menu Screen.....	100
Figure 85 – Calibration Menu Screen	100
Figure 86 – Pressure Calibration Menu Screen.....	101
Figure 87 – Ozone Calibration Menu Screen	102
Figure 88 – MFC Calibration Menu Screen	103
Figure 89 – Service Menu Screen	104
Figure 90 – Diagnostics Menu Screen.....	105
Figure 91 – Digital Pots Menu Screen.....	106
Figure 92 – Internal Pump Menu Screen	107
Figure 93 – Valve Menu Screen	108
Figure 94 – Tests Menu Screen.....	110
Figure 95 – Digital Input Test Menu Screen.....	110
Figure 96 – Digital Output Test Menu Screen.....	111
Figure 97 – Calculation Factors Menu Screen.....	111
Figure 98 – Communications Menu Screen	112
Figure 99 – Data Logging Menu Screen	113
Figure 100 – Serial Communication Menu Screen.....	113

Figure 101 – Analog Input Menu Screen	114
Figure 102 – Analog Output Menu Screen	115
Figure 103 – Digital Output Menu Screen	117
Figure 104 – Network Menu Screen.....	118
Figure 105 – Bluetooth Menu Screen	119
Figure 106 – Trend Display Menu Screen.....	120
Figure 107 – Chart Screen	121
Figure 108 – Advanced Menu Screen.....	122
Figure 109 – Hardware Menu Screen.....	123
Figure 110 – Communication Ports.....	127
Figure 111 – Multidrop RS232 Cable Example	128
Figure 112 – Example of Typical Network Setups	129
Figure 113 – Example of Network Menu Setup	130
Figure 114 – Port Forwarding Example	131
Figure 115 – LAN Network Set-Up (Airodis)	132
Figure 116 – WAN Network Set-Up (Airodis)	132
Figure 117 – 25 Pin Rear Panel PCA (Default Jumpers Highlighted).....	134
Figure 118 – Analog & Digital I/O Individual Pin Descriptions	135
Figure 119 – Installing Driver Software (Device Manager).....	136
Figure 120 – Update Driver Popup.....	137
Figure 121 – Update Driver Popup (Directory Location)	137
Figure 122 – Installing Driver Confirmation Prompt	138
Figure 123 – Successful Driver Installation.....	138
Figure 124 – Airodis Workspace Manager	139
Figure 125 – Adding a New Station	140
Figure 126 – New Station Connection.....	140
Figure 127 – Station Configuration (Channel List).....	141
Figure 128 – Error Status Notification.....	142
Figure 129 – Downloading Data	142
Figure 130 – Download Data Status	143
Figure 131 – Data Visibility.....	143
Figure 132 – Exporting Data	144
Figure 133 – Data Download Complete	144
Figure 134 – Downloading the App from Google Play Store	145
Figure 135 – Bluetooth Pairing Request.....	146
Figure 136 – Showing or Hiding the NumPad	147
Figure 137 – Switching Analysis	147
Figure 138 – Real-Time Plot	148
Figure 139 – Plot of Downloaded Data	149
Figure 140 – Directory Settings	150
Figure 141 – Logs Format.....	150
Figure 142 – Colour Theme Settings	151
Figure 143 – MFC Calibration Setup.....	154
Figure 144 – Port G: Test Flow Meter Shown Connected	156
Figure 145 – Ozone Flow Calibration 80 sccm	157
Figure 146 – Ozone Flow Calibration 100 sccm	157
Figure 147 – Disconnect inlet of Photometer	158
Figure 148 – Connect a Source of Diluent Air	160
Figure 149 – Connect to External Ozone Measurement Device.....	160
Figure 150 – Connect a Source of Diluent Air	161
Figure 151 – Connect a Source of Diluent Air	162
Figure 152 – Connect to External Ozone Transfer Standard	162
Figure 153 – Connect a Source of Diluent Air	163
Figure 154 – Connect to External Ozone Transfer Standard	163

Figure 155 – Connect a Source of Diluent Air	164
Figure 156 – Connect to External Ozone Transfer Standard.....	164
Figure 157 – Block Port ‘O3’ and O2’	165
Figure 158 – Minifit Extraction Tool - (PN: T030001)	167
Figure 159 – Orifice/Sintered Filter Removal Tool - (PN: H010046)	168
Figure 160 – Leak Test Jig - (PN: H050069).....	168
Figure 161 – Air Monitoring Test Equipment Kit (AMTEK) - Customisable.....	168
Figure 162 – Leak Test Jig to Exhaust Port.....	169
Figure 163 – Connect Vacuum Source.....	170
Figure 164 – Block the Output Ports.....	170
Figure 165 – Isolate Pressure Regulator	170
Figure 166 – Leak Check: Manual Point Setup.....	171
Figure 167 – Leak Check: Full Test	171
Figure 168 – Leak Check: Pump Bypass	172
Figure 169 – Leak Check: Isolate Photometer Valve States	172
Figure 170 – Leak Check: Isolate Photometer Schematic	173
Figure 171 – Leak Check: Isolate MFC’s Schematic.....	174
Figure 172 – Location of UV Lamp Securing Grub Screw	175
Figure 173 – Accessing the Service Display.....	176
Figure 174 – MFC Voltage Display	176
Figure 175 – Multi-MFC Setup Example (4 MFCs Installed).....	177
Figure 176 – Zero Flow Potentiometer Adjustment	177
Figure 177 – Final Voltage Check.....	177
Figure 178 – USB Memory Stick File Structure	182
Figure 179 – USB Memory Stick Failure Diagnostic Procedure	183
Figure 180 – Lamp Temperature Failure Diagnostic Procedure	184
Figure 181 – Separate Rack Slides	186
Figure 182 – Assemble Inner Slide on Chassis	186
Figure 183 – Rack Mount Ears Fitted to Instrument.....	187
Figure 184 – Attach Rack Mount Adaptors to Outer Slides	187
Figure 185 – Test Fit the Rack Slide Assembly into Your Rack	188
Figure 186 – Attach Slides to Front of Rack.....	188
Figure 187 – Slide Clips	189
Figure 188 – Additional Source Ports	190
Figure 189 – Additional Diluent Port	191
Figure 190 – Second Source MFC	192
Figure 191 – Second Diluent MFC.....	194

List of Tables

Table 1 – Internationally Recognised Symbols	14
Table 2 – Manual Revision History	19
Table 3 – List of Items Received	45
Table 4 – Digital Output States	117
Table 5 – Setting up a New Station via Airodis	140
Table 6 – Options Menu	147
Table 7 – Maintenance Schedule.....	168
Table 8 – Included Parts (Rack Mount Kit).....	185
Table 9 – Network Port Parts Added	189
Table 10 – Network Port Parts Removed.....	189
Table 11 – Additional Source Ports Parts Added	190
Table 12 – Additional Diluent Ports Parts Added	191
Table 13 – Second Source MFC Parts Added	192
Table 14 – Second Source MFC Removed.....	193

Table 15 – Second Diluent MFC Parts Added	194
Table 16 – Serinus Cal 1000 Maintenance Kit (PN: E020321)	195
Table 17 – Serinus Cal 2000 Maintenance Kit (PN: E020322)	195
Table 18 – Serinus Cal 3000 Maintenance Kit (PN: E020323)	195
Table 19 – Serinus Accessories Kit	196
Table 20 – Serinus Cal Consumables	196
Table 21 – Spare Parts List (Main Components)	197
Table 22 – Spare Parts List (Cables).....	198
Table 23 – Spare Parts List (O-rings)	199
Table 24 – Spare Parts List (Fittings)	199
Table 25 – Spare Parts List (Miscellaneous)	200
Table 26 – Spare Parts List (Shipping)	201
Table 27 – Packet Format.....	215
Table 28 – Example: Primary Gas Request	215
Table 29 – Example: Primary Gas Response.....	216
Table 30 – Example: Primary Gas Response (continued)	216
Table 31 – List of Errors.....	216
Table 32 – Example: Get IEEE Response data	217
Table 33 – Gas Indexes.....	218
Table 34 – Unit Indexes.....	219
Table 35 – Port Indexes.....	219
Table 36 – Mode Control	220
Table 37 – Purge Control.....	221
Table 38 – Port Defination	221
Table 39 – Gas Standard Definition.....	222
Table 40 – Point Definition.....	223
Table 41 – Sequence Definition	224
Table 42 – Ozone Calibration	225
Table 43 – Calibration Mode Indexes.....	226
Table 44 – Mode Selection.....	226
Table 45 – Diluent Port Selection	227
Table 46 – Source Port Selection.....	227
Table 47 – Flow	227
Table 48 – Gas Selection	228
Table 49 – Custom Gas Definition Sub Command.....	228
Table 50 – Molecular Structure Index	228
Table 51 – Advanced Protocol Parameter List	229
Table 52 – Bayern-Hessen Data	243
Table 53 – Block Check Operation.....	244
Table 54 – Status Bit Map	245
Table 55 – Failure Bit Map (Positive Logic)	245
Table 56 – Modbus Error Codes.....	249
Table 57 – Native Serial Commands.....	251

List of Appendices

Appendix A.	Advanced Protocol.....	215
A.1	Command Format.....	215
A.2	Commands.....	216
A.3	List of Parameters.....	229
Appendix B.	EC9800 Protocol	241
B.1	Command Format.....	241
B.2	Commands.....	241
Appendix C.	Bayern-Hessen Protocol	243
C.1	Command Format.....	243
C.2	Commands.....	244
Appendix D.	ModBus Protocol	247
D.1	Command Format.....	247
D.2	Commands.....	248
Appendix E.	Gascal Protocol	251
Appendix F.	Beer-Lambert Law.....	253

Manufacturer's Statement

Thank you for selecting the Acoem Serinus Cal 1000, 2000 & 3000.

The Serinus Cal is designed primarily as a Dilution Calibrator used in conjunction with gas cylinders to supply precise concentrations of span gas to gas analysers.

This User Manual provides a complete product description including operating instructions, calibration, and maintenance requirements for the Serinus Cal 1000, 2000 & 3000.

Reference should also be made to the relevant local standards, which should be used in conjunction with this manual. Some of these standards are listed in this manual.

If, after reading this manual you have any questions or you are still unsure or unclear on any part of the Serinus Cal 1000, 2000 & 3000, please do not hesitate to contact Acoem or your local Acoem distributor.



Please help the environment and recycle the pages of this manual when you have finished using it.

Notice

The information contained in this manual is subject to change without notice. Acoem reserves the right to make changes to equipment construction, design, specifications and/or procedures without notification.

Ecotech Pty. Ltd. has changed its trading name to Acoem Australasia.

Copyright © 2026. All rights reserved. Reproduction of this manual, in any form, is prohibited without the written consent of Acoem Australasia.





This work is copyright. Apart from any use permitted under the Copyright Act 1968, no part may be reproduced by any process, nor may any other exclusive right be exercised, without the permission of Acoem Australasia, 19/21 Brenock Park Dr, Ferntree Gully VIC 3156, copyright © 2026.

Safety Information

Read all the safety information in this section prior to using the equipment. To reduce the risk of personal injury caused by potential hazards, follow all safety notices and warnings in this documentation.

The following internationally recognised symbols are used on Acoem Australasia equipment:

Table 1 – Internationally Recognised Symbols







	Protective conductor terminal	IEC 60417-5019
	Alternating current	IEC 60417-5032
	Caution, hot surface	IEC 60417-5041
	Caution, risk of danger to user and/or equipment Refer to any accompanying documents	ISO 7000-0434
	Caution, risk of electric shock	ISO 3864-5036

These symbols will also be found throughout this manual to indicate relevant safety messages.

Note: Notes are used throughout this manual to indicate additional information regarding a particular part or process.

If the equipment is used for purposes not specified by Acoem Australasia, the protection provided by this equipment may be impaired.

Important Safety Messages

	<p>Disconnect Power Prior to Service</p> <p>Hazardous voltages exist within the instrument. Do not remove or modify any of the internal components or electrical connections whilst the mains power is ON.</p> <p>Always unplug the equipment prior to removing or replacing any components.</p>
	<p>Replacing Parts</p> <p>Replacement of any part should only be carried out by qualified personnel, using only parts specified by Acoem Australasia, as these parts meet stringent Acoem Australasia quality.</p>
	<p>Mains Supply Cord</p> <p>Do not replace the detachable mains supply cord with an inadequately rated cord. Any mains supply cord that is used with the instrument must comply with the safety requirements (250 V/10 A minimum requirement). A mains power cord with a protective earth conductor must be used.</p> <p>Ensure that the mains supply cord is maintained in a safe working condition.</p>
	<p>Do Not Expose Equipment to Flammable Gases</p> <p>This equipment is not intended for use in explosive environments, or conditions where flammable gases are present. The user should not expose the equipment to these conditions. Do not introduce any flammable gases into the instrument, otherwise serious accidents such as explosion or fire may result.</p>
	<p>Electromagnetic Compliance</p> <p>The instrument lid should be closed when in normal operation, to comply with EMC regulations.</p>
	<p>Means of Lifting/Carrying Instrument</p> <p>This instrument is a heavy and bulky object. Two persons should lift/carry the object, otherwise use proper lifting equipment. Proper lifting techniques should be used when moving the instrument.</p>
	<p>Internal Components</p> <p>Do not insert a rod or finger into the cooling fans, otherwise injury may result.</p> <p>Do not energise the instrument until all conductive cleaning liquids, used on internal components, are dried up.</p>
	<p>UV Lamp</p> <p>The Serinus Cal 2000 and 3000 contain UV Lamps that emit harmful UV radiation. Be sure to turn the instrument power OFF during UV lamp replacement or use UV protective eyewear if necessary to adjust the lamps whilst operating.</p>

Warranty

This product has been manufactured in an ISO 9001 facility with care and attention to quality.

The product is subject to a 24-month warranty period on parts and labour from date of shipment. The warranty period commences when the product is shipped from the factory. Lamps, filters and other consumable items are not covered by this warranty.

Each calibrator is subjected to a vigorous testing procedure prior to despatch and will be accompanied with a parameter list and a multipoint calibration check thereby enabling the calibrator to be installed and ready for use without any further testing.

Service and Repairs

Service Guidelines

This manual is designed to provide the necessary information for the setup, operation, testing, maintenance, and troubleshooting of your instrument.

Should you still require support after consulting the documentation, we encourage you to contact your local distributor for support.

To contact Acoem directly, please e-mail our Technical Support Specialist group at

support-em@acoem.com

Please contact Acoem and obtain a Return Material Authorization (RMA) number before sending any equipment back to the factory. This allows us to track and schedule service work and to expedite customer service. Please include this RMA number when you return equipment, preferably both inside and outside the shipping packaging. This will ensure you receive prompt service.

When shipping instrumentation, please also include the following information:

- Name and phone number
- Company name
- Shipping address
- Quantity of items being returned
- Model number/s or a description of each item
- Serial number/s of each item (if applicable)
- A description of the problem and any fault-finding completed
- Original sales order or invoice number related to the equipment

Contact Details:

Technical Support: support-em@acoem.com

Product Compliance and Approvals

The Serinus Cal 1000, 2000 & 3000 Dilution Calibrator, as manufactured by Plot No 57 Pithampur, Sector 2, Indore, Madhya Pradesh 454775, India, complies with the essential requirements of the directives listed below (including CE compliance). The respective standards have been applied:



Low Voltage Directive (LVD) 2006/95/EC

EN 61010-1:2013

Safety requirements for electrical equipment, for measurement control and laboratory use (3rd edition) – Part 1: General requirements

Electromagnetic Compatibility (EMC) Directive 2004/108/EC

EN 61326-1:2013

Electrical Equipment for measurement, control and laboratory use – EMC Requirements – Part 1: General requirements

Radio and Telecommunication Terminal Equipment (R&TTE) Directive 1999/5/EC

EN 300 328 V1.7.1:2006

Electromagnetic compatibility and Radio spectrum Matters (ERM); Wideband transmission systems; Data transmission equipment operating in the 2.4GHz ISM band and using wide band modulation techniques.



Regulatory Compliance Mark (RCM) - Australia

EN 61326-1:2013

Electrical Equipment for measurement, control and laboratory use - EMC Requirements - Part 1: General requirements

AS/NZS 4268:2012

Radio equipment and systems - Short range devices - Limits and methods of measurement

Manual Revision History

Manual PN: M010057
 Current revision: 4.1
 Date released: 5 June 2026
 Description: User Manual for the Serinus Cal 1000, 2000 & 3000 Dilution Calibrator

This manual is the full user manual for the Serinus Cal 1000, 2000 & 3000 Dilution Calibrator. This manual contains all relevant information on theory, specifications, installation, operation, maintenance and calibration. Any information that cannot be found within this manual can be obtained by contacting Acoem.

This manual uses cross reference links extensively throughout this manual. The hot keys below will greatly reduce the amount of time scrolling between references:

- You can access the links by pressing the following:
 - > CTRL + LEFT MOUSE CLICK: Move to the link location
- You can switch between links by pressing the following:
 - > ALT + LEFT ARROW KEY: Returns you to previous Link
 - > ALT + RIGHT ARROW KEY: Swaps back

Table 2 – Manual Revision History

Edition	Date	Summary
1.0		Initial release
1.1	Feb 2017	Added Trend Display Menu Edit Custom Gasses Menu Readout Calibration Quick Menu Points/Seq Log Instrument gain Internal pump Measurement Setting Menu Calibration Menu Appendix Advanced protocol Optional Extras Updated home screen image Lamp driver images & text Manual aligned to firmware 3.55.000
1.2	Dec 2018	Added Advanced Parameters for PCT Photometer Corrected Titration Revised

Edition	Date	Summary
		Advanced Parameters for Mode, Point, Sequence Manual aligned to firmware 3.79.001
1.3	March 2022	Manual update to firmware 4.18.0 Rev. Q board. A number of changes to descriptions, procedures and menu items. Standardization of naming convention applied.
4.0	September 2025	Manual update to firmware 4.32.0 Rev. R board. Firmware and hardware references updated to reflect latest versions.
4.1	May 2026	Updates were made to include the new detector in the photometer assembly. Spare part detector assemblies C010007-02 and H013111-01 were included.

1. Introduction

1.1 Description

The Serinus Cal has been designed as a stand-alone dilution calibrator specifically for environmental applications and should give many years of trouble-free service provided that it is installed, used and maintained correctly.

It can be used in conjunction with many different analysers measuring gases such as CO, CO₂, O₃, NO_x, NO_y, NH₃ and SO₂ to provide precise and constant volumes of zero air or dilutions of various calibration gases.

The Serinus Cal is used in conjunction with regulatory traceable gases, and zero air generators. The Serinus Cal 2000 provides the additional feature of an Ozone generator so that it can produce O₃ to be used when performing a Gas Phase Titration (GPT).

The Serinus Cal 3000 includes an Ozone generator as well as an Ozone photometer, enabling the accurate production and delivery of O₃ concentrations for the calibration of O₃ analysers. It also allows for the generation of precise NO₂ concentrations, required for the span calibration of direct NO₂ measurement analysers. In addition, the Ozone generator can be used to perform Gas Phase Titration, which is the preferred method for verifying the efficiency of NO₂ to NO converters.

This section will describe the specifications of the calibrator as well as the main components and techniques used to provide stable gas concentrations.

1.2 Specifications

1.2.1 Dilution & Span Flows

Range

Input dilution gases:	1 port (standard) 120 - 180 kPa (g) 2 ports (optional) 120 - 180 kPa (g)
Input source gases:	1 to 4 (standard) 100 - 300 kPa (g) 1 to 8 (optional) 100 - 300 kPa (g)
Dilution mass flow controller:	0 - 10 slpm, (STD 0°C, 1.000 ATM) (standard) 0 - 1, 0 - 2, 0 - 5 or 0 - 20 slpm (optional)
Source mass flow controller:	0 - 50 sccm (STD 0°C, 1.000 ATM) (standard) 0 - 10 sccm, 0 - 20 sccm, 0 - 100 sccm, 0 - 200 sccm, 0 - 500 sccm, 0 - 1000 sccm, 0 - 2 slpm or 0 - 5 slpm (optional)

Precision/Accuracy

Flow accuracy (constant temp):	Within 1 % of full scale
Flow repeatability:	Within 0.15 % of full scale

Linearity:	Within 0.15 % of full scale
Operating gas pressure:	100 - 200 kPa (Damage may occur if the pressure exceeds 200 kPa)
Zero drift:	< 0.58 % per year
Response time:	< 5 seconds
Output manifold:	4 output ports (standard)
Dilution ratio:	Variable 20:1 to 2000:1 (standard)

1.2.2 Power

Operating Voltage

100 - 240 VAC ($\pm 10\%$)

50/60 Hz (autoranging)

Power Consumption

Maximum:	Serinus Cal 1000 52 VA
	Serinus Cal 2000 74 VA
	Serinus Cal 3000 130 VA
Operating:	Serinus Cal 1000 52 VA
	Serinus Cal 2000 63 VA
	Serinus Cal 3000 87 VA

1.2.3 Operating Conditions

Ambient Temperature Range

0 °C to 40 °C (32 °F to 104 °F), 20 °C to 35 °C for optimum performance.

Pressure

Maximum altitude: 3000 m above sea level

1.2.4 Communications

User Interface

- Via front panel keypad or computer

Programmable Calibrations

- 16 separate programmable sequences
- 64 separate programmable points

Analog Output (Serinus Cal 3000 only)

- Voltage output of 0 - 5 V, with menu selectable zero offset of 0 V, 0.25 V or 0.5 V.
- Range: User scalable min and max range for analog output to suit application.

Analog Input

- Three analog voltage inputs (0 - 5 VDC) CAT I rated.

Digital Output

- RS232 port #1 : Normal digital communication.
- RS232 port #2 : Multidrop port used for multiple instrument connections on a single RS232.
- USB port connection on rear panel.
- 25 pin connector with discrete status and user control.
 - o Eight Digital Outputs, open collector max 400 mA each @ 12 VDC (max total output 2 A).
 - o Eight Digital Inputs, 0 - 5 VDC, CAT I rated.
- USB memory stick (front panel) for data logging, event logging and parameter storage.
- 1 Diluent Control, +12 V output.
- TCP/IP (optional)

1.2.5 Physical Dimension

Case Dimensions

Rack length (front to rear):	622 mm (24.5")
Total length (with latch release):	662 mm (26.1")
Chassis width:	418 mm (16.5")
Front panel width:	429 mm (16.9")
Chassis height:	163 mm/uses 4RU (6.4")
Front panel height:	185 mm (7.3")
Weight:	Serinus Cal 1000 18 kg Serinus Cal 2000 20 kg Serinus Cal 3000 24.8 kg

1.2.6 Ozone Generator [Serinus Cal 2000]

Output:	3 ppb to 5000 ppb
Repeatability:	< 1 % short term (24 hours) 5 % long term at constant temperature and humidity

1.2.7 Photometer [Serinus Cal 3000]

Range

0 - 20 ppm

Precision

0.5 ppb or 0.2 % of reading, whichever is greater

Linearity

<1 % of full scale

Noise at Zero

<0.25 ppb

Response Time

30 seconds to 95 %

1.2.7.1 Calibration

Zero Drift

Temperature dependant: 1.0 ppb per °C

24 hours: < 0.3 ppb

7 days: < 0.3 ppb

Span Drift

Temperature dependant: 0.1 % per °C

7 days: 0.5 % of reading

1.3 Nomenclature

O₃	This is the abbreviation for Ozone.
Bootloader	A program that checks whether the current firmware is valid, then executes the instrument start-up. The bootloader can be entered by pressing the '+' key on the front keypad during the first ½ second after power ON, and following the prompts. The bootloader enables various low level recovery tools, including updating the main firmware from a USB memory stick.
Diluent	Diluent gas is a clean, unreactive gas used to dilute reactive samples via the Diluent Port.
Source Gas	Source gas or gas standard is the name given to the certified gas cylinder that is connected to one of the source ports. To be mixed with diluent gas to make a known span concentration.

Exhaust Air	The exhaust port is where excessive calibration gases and Ozone are exhausted from the instrument.
ID and OD	These are measurements of tubing. ID is the internal diameter of tubing, OD is the outer diameter.
Multidrop	A configuration of multiple calibrators and/or analysers connected via the same RS232 cable.
Span	A gas sample of known composition and concentration used to calibrate/check the upper range of an instrument.
Zero	Zero air to calibrate/check the lower range of an instrument.
Point	A single operation such as a dilution.
Sequence	A group of points and operations.
Background	Is the reading of the instrument without Ozone present in the measurement cell. In the case of the Serinus Cal 3000, the background measurement is performed using zero air.
Calibration	The process of adjusting an instrument to ensure that it is measuring the correct concentration.
Zero Drift	The change in instrument response to zero air over a period of continuous unadjusted operation.
Zero Air	Is purified air in which contaminants are removed to a level below what is detectable by the instruments used within the calibration system. In a typical ambient air monitoring station this normally includes water vapour, hydrocarbons, O ₃ , NO, NO ₂ , SO ₂ , H ₂ S and CO.
PCA	Printed Circuit Assembly. An electronic circuit mounted on a printed circuit board to perform a specific electronic function.
Slpm	Standard litres per minute. This is the flow referenced to standard temperature and pressure conditions. For the purposes of this manual, all flows are referenced to 0 °C and 101.3 kpa (1 atm).
GPT	Gas Phase Titration.

1.4 Background/Theory

1.4.1 Dilution Theory

The Serinus Cal operates on the principle that when a known quantity of source gas is mixed with a known quantity of diluent gas, the resultant mixture can be calculated. The assumption relies on the conservation of mass which occurs if there is no loss of the source gas via chemical reaction between

the source component gas(es) and the diluent gas. In that case we can write that for each compound (i), the mass (m), entering the system is equal to the mass exiting the system:

$$m_i|_{in} = m_i|_{out}$$

In other words,

$$Concentration_i|_{in} \times FlowRate_i|_{in} = Concentration_i|_{out} \times FlowRate_i|_{out}$$

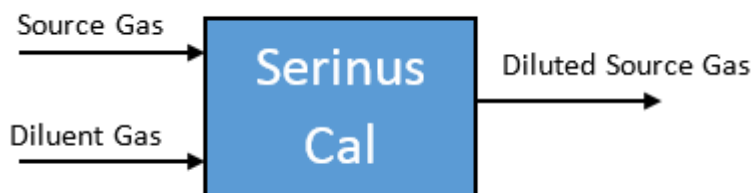

Figure 1 – Dilution Theory for Serinus Cal

So, according to the mass balance and considering Figure 1:

$$C_{source} \times F_{source} + C_{diluent} \times F_{diluent} = C_{output} \times F_{output}$$

Where C_i = Concentration

F_i = Mass flow rate

As the diluent is always chosen as a “chemical free gas”, the term $C_{diluent}$ is always zero. This simplifies the equation to:

$$C_{source} \times F_{source} = C_{output} \times F_{output}$$

Since we also know that the total mass flow rate is also conserved:

$$F_{output} = F_{source} + F_{diluent}$$

The equation becomes:

$$C_{source} \times F_{source} = C_{output} \times (F_{output} + F_{diluent})$$

This can be rearranged to give:

$$C_{output} = \frac{C_{source} \times F_{source}}{F_{source} + F_{diluent}}$$

This is the governing equation used in the operation of the Serinus Cal.

The mass flow rates of the source gas and diluent gases are accurately measured using mass flow controllers. Suppliers usually certify the source gas cylinder concentration, allowing the concentration of the output to be calculated easily.

1.4.2 Ozone Photometer Theory [Serinus Cal 3000]

This section outlines the relevant theory for Serinus Cal 3000 which contains an Ozone (O₃) photometer and Ozone generator.

The photometer accurately measures and controls the Ozone concentration generated by an internal generator, allowing its use as a transfer standard to calibrate Ozone analysers.

The Serinus Cal follows these principles and measurement techniques:

- The ozone photometer measures ozone concentration by using the Beer-Lambert law and UV absorption principles. The instrument draws in calibration air and exposes it to UV light. A detector then measures the remaining UV intensity.
- To account for interference, the photometer alternates between ozone-free air and calibration air every 10 seconds. This process produces reference and measurement UV intensity values. A microprocessor then uses these values, along with ambient temperature, pressure, and calibration factors, to calculate the final ozone concentration.

Note: In order to obtain the desired stability levels necessary for Ozone analyser calibrations, the user should run the Serinus Cal 3000 at the same Ozone concentration for at least 30 minutes to obtain a sufficiently stable output.

1.4.3 Explanation Photometer Transfer Standards

In ambient air monitoring applications, precise Ozone concentrations called *standards* are required for the calibration of Ozone analysers. Due to the instability of Ozone, concentrations must be generated and “verified” on site with another instrument referred to as a transfer standard.

A transfer standard is defined as a transportable device or apparatus which is capable of accurately reproducing Ozone.

The transfer standard’s purpose is to transfer the authority of a Level 1 pollutant standard to a remote point where it is used to verify or calibrate an air monitoring analyser.

The U.S. EPA identifies the family of standard reference photometers (SRPs) as Level 1 standards.

Beyond the SRPs, all standards are considered transfer standards and are numbered (starting with 2) based on their ‘distance in the traceability chain’ from a verification against a Level 1 standard. With each additional level, the number of standards available is multiplied. Each standard is traceable through a chain of “higher” standards to the Level 1 standard.

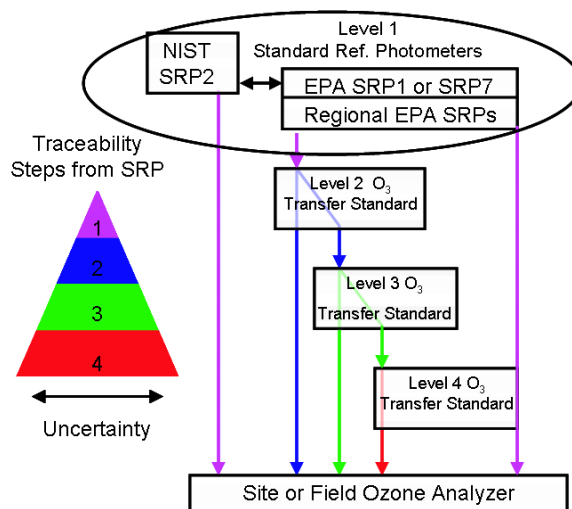

Figure 2 – Ozone Transfer Standard Hierarchy

The majority of transfer standards include both Ozone generators and photometers. Therefore, it is strongly suggested that:

- **Level-2 standards** used in the verification of other transfer standards include both a generation device and a photometer. (Serinus Cal 3000)
- **Level-3 standards** at a minimum, a photometer (Serinus 10). The level 3 standard can be a photometer and generator (Serinus 10 or Serinus Cal 3000) but should not be just a generator.
- **Level-4 standards** can be an Ozone generation device (Serinus Cal 2000)

Ozone Transfer Standards also require routine calibration against a higher transfer standard. Please refer to your local standard.

Acoem is able to offer a Level 2 and lower Ozone calibration service.

1.5 Instrument Description

1.5.1 Common Components

In this section we describe the components that are common to all Serinus Cal models.

1.5.1.1 Main Controller PCA

The main controller PCA controls all the processes within the instrument. As well as the on-board microprocessor, it contains a battery backed clock-calendar, analog to digital converters and many other circuits for signal processing and control. The ambient pressure and chassis temperature sensors are also located on this board. The main controller PCA is located above all other components within the instrument. It pivots on hinges to allow access to the components underneath.

Refer to Figure 9 for CAL 1000.

Refer to Figure 10 for CAL 2000.

Refer to Figure 13 for CAL 3000.



CAUTION

Never place objects on top of the main controller PCA as it may result in damage.

1.5.1.2 Rear Panel PCA

The rear panel PCA contains all the communications connections for the user through the rear panel. This PCA also controls all the internal solenoid bullet valves as well as the Diluent control. This PCA has its own power connection directly from main controller PCA.

Refer to Figure 9 for CAL 1000.

Refer to Figure 10 for CAL 2000.

Refer to Figure 13 for CAL 3000.

Note: The Serinus Cal may be supplied either with or without a network port, depending on configuration. Units without network connectivity use PCA PN: C010002-02, while those with a tested network interface use PCA PN: C010002-20. The installed network option corresponds to PN: E020317.

1.5.1.3 USB Memory Stick

The USB memory stick supplied with the instrument is a **critical component for normal operation** and must remain installed at all times during use. It is located on the front panel of the analyser (refer to Figure 26).

- The USB memory stick performs the following essential functions:
- Stores instrument configuration and parameter files.
- Facilitates internal data logging and event recording.
- Stores diagnostic and technical support files for troubleshooting.
- Enables firmware upgrades and system recovery operations.
- Saves automatic backups, including scheduled system snapshots.

Failure to keep the USB memory stick installed may result in **loss of data logging, inability to perform firmware updates, and limited diagnostic capability**.

Formatting Procedure

If the USB memory stick becomes full, corrupted, or requires reformatting, perform the following:

- Format the USB memory stick using:
 - File System: FAT32 (Default)
 - Cluster Size: 16 KB
- Before formatting:
 - Back up all existing data to an external device.
- After formatting:
 - Restore required files (if applicable) before reinserting the USB memory stick into the instrument.

Notes and Precautions

- Only use USB memory sticks supplied or approved by Acoem.
- Do not remove the USB memory stick while the instrument is powered ON, unless instructed for maintenance or data transfer.
- Improper removal may lead to data corruption or system errors.

1.5.1.4 Solenoid Bullet Valves

The solenoid bullet valves control the flow path of the instrument. Valves V1 to V4 are labelled S1 to S4 on the rear panel and V6 to V8 are stamped on the Ozone mixing manifold. They are designated the same in the analyser firmware.



Figure 3 – Solenoid Bullet Valve

In their energised state or “ON” state a red led lights up on the tip of the valve and this makes troubleshooting faulty valve states very easy.

Refer to Figure 9 for CAL 1000.

Refer to Figure 10 for CAL 2000.

Refer to Figure 13 for CAL 3000.

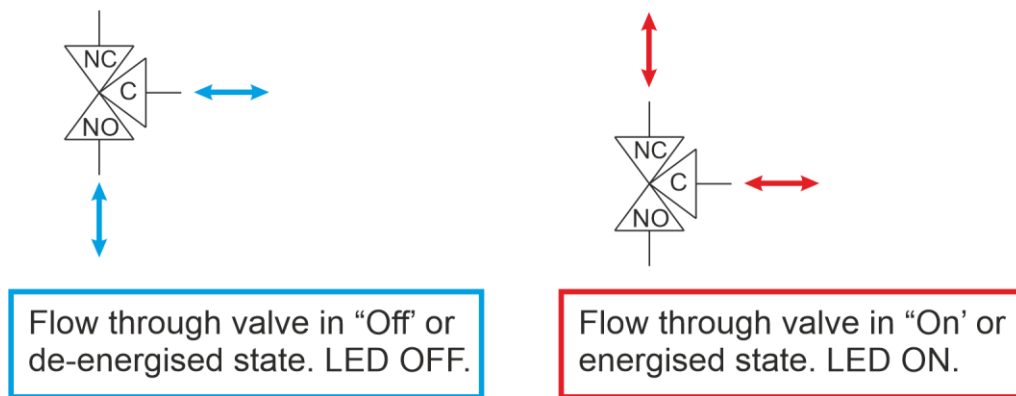

Figure 4 – Solenoid Bullet Valve Operation

1.5.1.5 Pressure Sensor PCA

The Serinus Cal 1000 has a pressure sensor installed on the main controller PCA to monitor the ambient pressure.

The Serinus Cal 2000 has a pressure sensor installed on the main controller PCA to monitor the ambient pressure. An additional differential pressure sensor is installed on the mixing manifold to monitor the flow of the output of the Ozone generator, refer to Figure 10.

The Serinus Cal 3000 has a pressure sensor installed on the main controller PCA to monitor the ambient pressure. An additional differential pressure sensor is installed on the mixing manifold to monitor the flow of the output of the Ozone generator. Lastly there are two more ambient pressure sensors installed on the photometer assembly and on the flow block to monitor the flow through the photometer, refer to Figure 13.

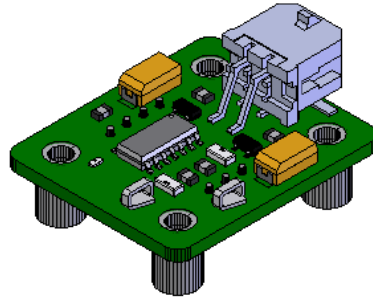

Figure 5 – Differential Pressure Sensor PCA

1.5.1.6 Power Supply

The power supply is a self-contained unit housed in a steel case designed to meet all the relevant safety and EMC requirements. This power supply is autoranging.

The output of the power supply provides +12 V, +5 V, -12 V and +3.3 V to the instrument.

Refer to Figure 9 for CAL 1000.

Refer to Figure 10 for CAL 2000.

Refer to Figure 13 for CAL 3000.

ON/OFF Switch

The ON/OFF switch is located on the rear panel (bottom right facing the rear of the instrument), refer to Figure 6. It is part of the power supply.



Figure 6 – Power ON/OFF Switch

1.5.1.7 MFC

A mass flow controller (MFC) is a device that is used to measure and control the flow of gases at a particular flow rate. It is controlled by the main controller PCA and is used to give the user the desired output concentration as defined in the point setup. There are 2 MFC in each Serinus Cal as standard regardless on the model. There are two optional MFC's available, a second diluent MFC and a second source MFC.

Refer to Figure 9 for CAL 1000.

Refer to Figure 10 for CAL 2000.

Refer to Figure 13 for CAL 3000.

1.5.1.8 DFU

A build-up of particulate matter on the diluent MFC's is prevented by a disposable filter unit (DFU).

Refer to Figure 9 for CAL 1000.

Refer to Figure 10 for CAL 2000.

Refer to Figure 13 for CAL 3000.

1.5.1.9 Inlet Manifold

The inlet manifold is comprised of four individual solenoid bullet valves that are used for selecting source gas from external pressurised vessels. The inlet manifold then delivers them to the mass flow controller for precise mixing of source gas.

Refer to Figure 9 for CAL 1000.

Refer to Figure 10 for CAL 2000.

Refer to Figure 13 for CAL 3000.

1.5.1.10 Output Manifold

The output manifold is a common set of ports used as the conduit for delivering the final user defined diluted gas concentration to its final destination. When the gas leaves the calibrator it will be at ambient pressure. This is achieved by always allocating one of the 4 common ports as a vent leading to atmosphere.

Refer to Figure 9 for CAL 1000.

Refer to Figure 10 for CAL 2000.

Refer to Figure 13 for CAL 3000.

1.5.1.11 Pneumatic Tubing

The pneumatic tubing inside this instrument is specially designed for use in Acoem Serinus instruments. It is flexible like silicone tubing with the added inner sheath of PVDF to prevent contamination of the sample. Care should be taken when removing and inserting the tubing into the fittings.

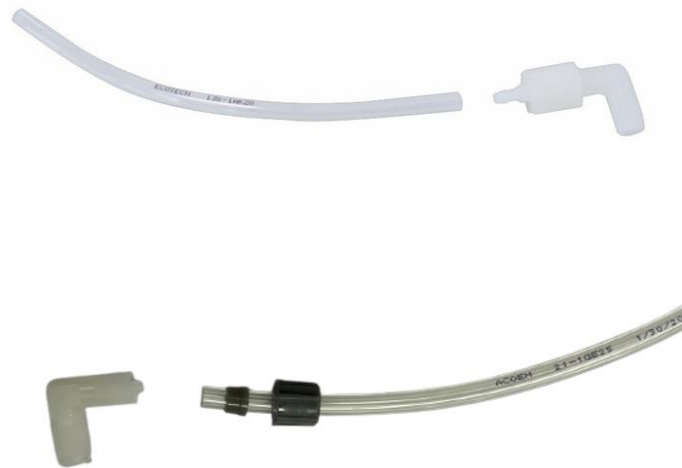

Figure 7 – Acoem Tubing

1.5.1.12 Communications Connections

There are a number of ways to communicate with the instrument (refer to Figure 8). The user can use the supplied Airodis software to access the instrument and download data. The Airodis software is supplied on the green resources USB stick provided with this instrument. The instrument can also be controlled and its data logged using other hardware/software, such as Congrego.

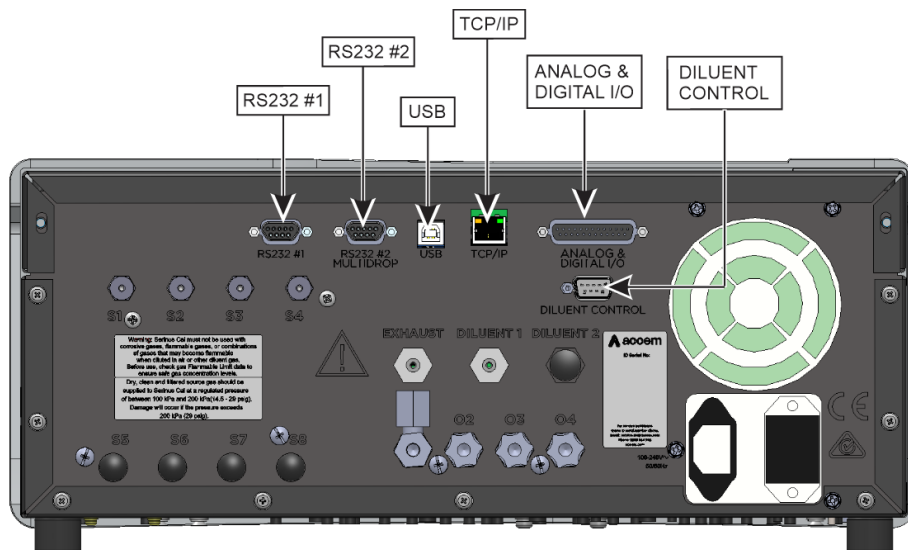

Figure 8 – Communication Connections

RS232 #1

This port is designed to be used for simple RS232 communication.

RS232 #2

This port is designed to be used for simple RS232 communication or in multidrop configuration.

Note: When using multidrop ensure each instrument is given a unique instrument ID.

USB

This port can be used for instrument communications with equipment through a standard USB port.

TCP/IP (optional)

This port is best used for remote access and real-time access to instruments when a network is available to connect with.

Analog/Digital

This port is used to send and receive analog and digital signals between instruments. It is normally used to connect with a gas analyser or data logger to activate calibration points and sequences.

Each instrument contains 8 digital inputs, 8 digital outputs, 3 analog inputs and 1 analog output.

Note: Analog output menu only appears on a Serinus Cal 3000.

Diluent Control

This port is used to control an external Zero Air Generator (such as the Acoem 8301LC) by providing a 12 V signal when the diluent is required.

Bluetooth (optional)

This allows for remote access of the instrument to any Android device with the **Serinus Remote Application** installed. It uses Bluetooth to control the instrument, view parameters, download data and construct real-time graphs.

1.5.2 Serinus Cal 1000 Components

The Serinus Cal 1000 is a stand-alone dilution calibrator designed specifically for environmental applications. The Serinus Cal 1000 can be used in conjunction with many different gas analysers and provides precise and constant volumes of zero air or dilutions of various span gases.

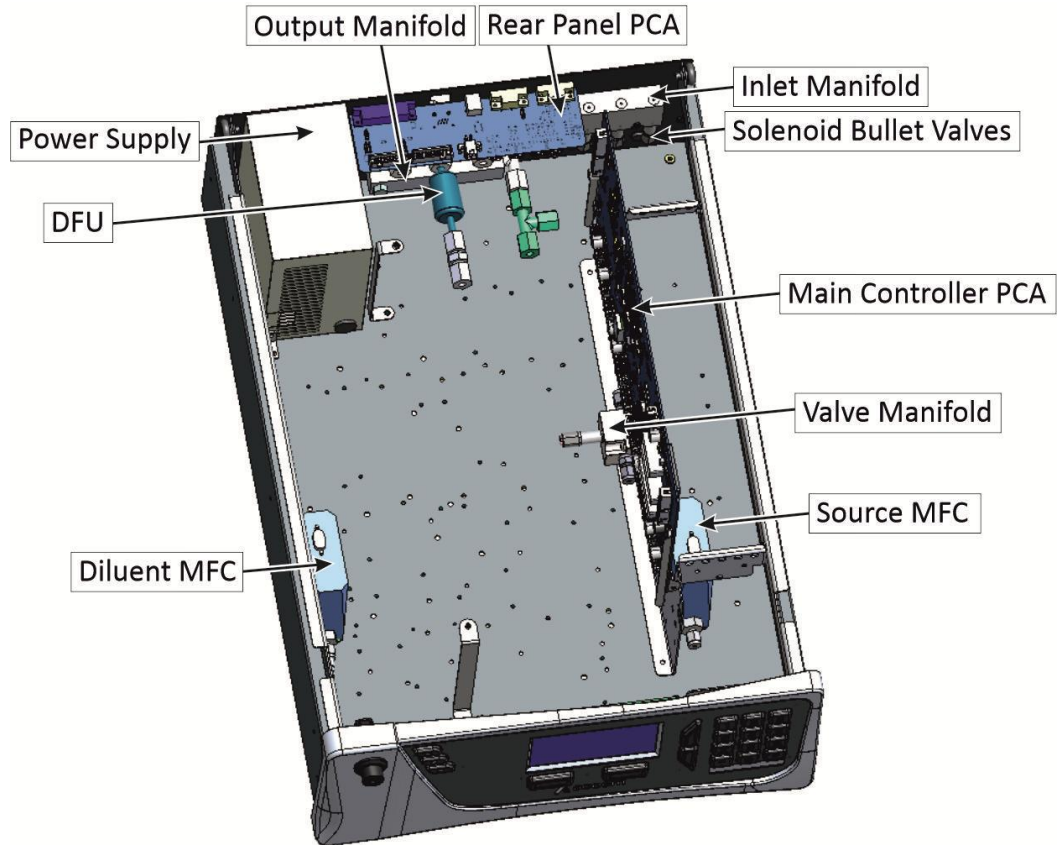

Figure 9 – Major Components of Serinus Cal 1000

1.5.3 Serinus Cal 2000 Components

The Serinus Cal 2000 provides an additional Ozone generator. This allows the Serinus Cal 2000 to run GPT calibrations of Ozone with precise dilution rates. There are a few structural changes compared to the Serinus Cal 1000 to incorporate the option.

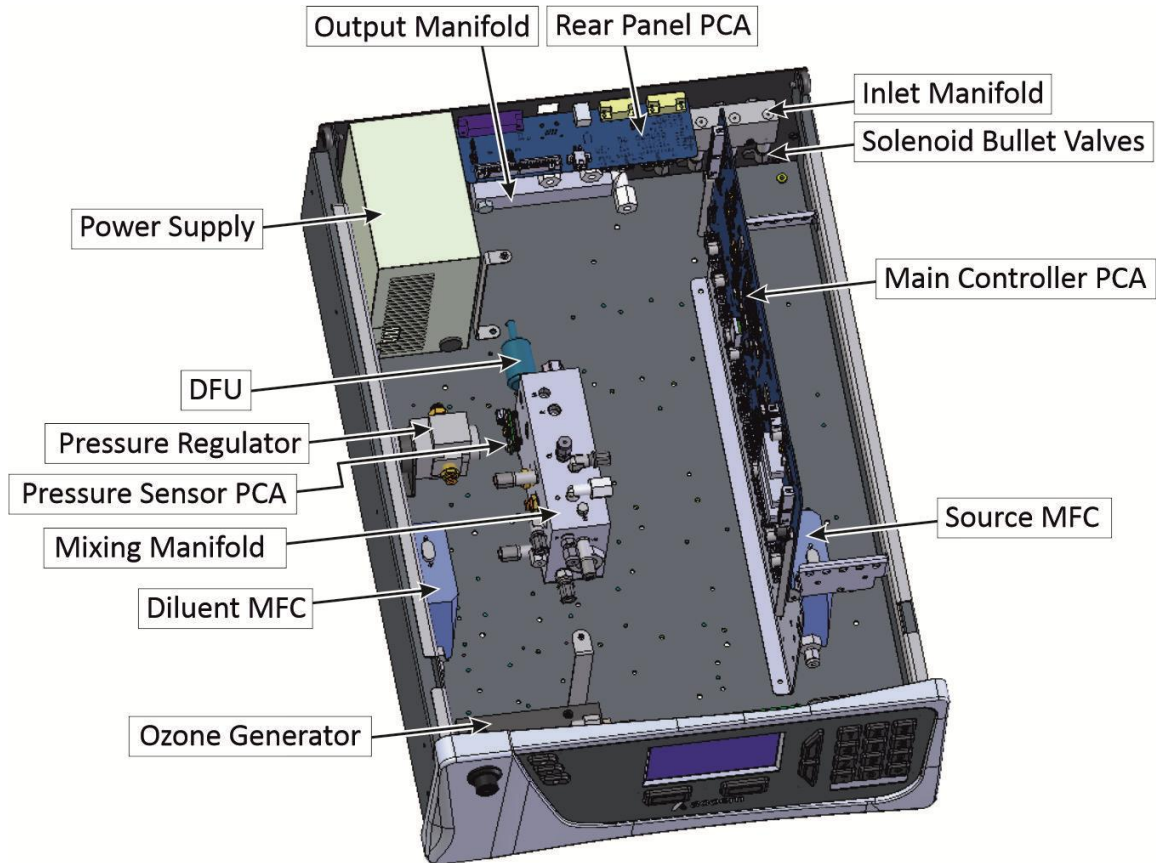

Figure 10 – Major Components of Serinus Cal 2000

1.5.3.1 Ozone Generator

Refer to Figure 10 for the location of Ozone generator. The Ozone generator consists of a pressurized chamber, Ozone producing ultraviolet lamp, heater thermistor assembly, gas inlet and outlet, fittings and Ozone generator controller PCA. Together these components produce Ozone which is fed into the Ozone mixing manifold.

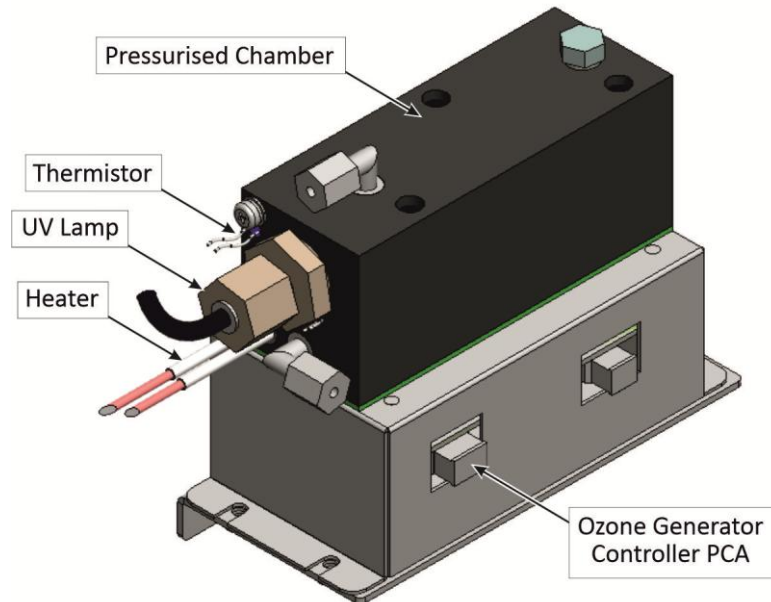

Figure 11 – Ozone Generator Assembly

UV Lamp

The location of the UV lamp is shown in Figure 11. The UV lamp, powered by the ozone generator controller PCA, is used to irradiate zero air with UV light at 254 nm, converting the oxygen in the air into ozone.

Ozone Generator Controller PCA

Refer to Figure 16 for the location of UV lamp. The lamp driver PCA is mounted under the pressurized chamber. The Ozone Generator Controller PCA generates a high-frequency voltage to power the UV lamp. The intensity of lamp is adjusted depending on amount of ozone required to be generated.



CAUTION

The lamp driver PCA contains high voltages. Ensure instrument is turned OFF before accessing this component.

Pressurised Chamber

The pressurized chamber is a small inert vessel that is used to receive dry, scrubbed air at a regulated pressure from the pressure regulator. This is then activated and excited by the UV lamp to generate ozone.

Heater and Thermistor

Refer to Figure 11 for the location of heater and thermistor. The heater and thermistor are mounted in the pressurised chamber. They are used to keep the chamber temperature at a stable and constant 50 °C.

1.5.3.2 Mixing Manifold (Serinus Cal 2000)

Refer to Figure 10 for the location of mixing manifold. This manifold contains the solenoid bullet valves, the Ozone mixing chamber and the Ozone flow pressure board. It also houses the orifice which controls the flow from the Ozone generator to the Ozone mixing chamber. As the name suggests all the gases pass through this manifold and mix to form the user defined gas concentration. All the ports are labelled with letters A through to R to help identify them using the plumbing diagram (refer to Section 1.1).

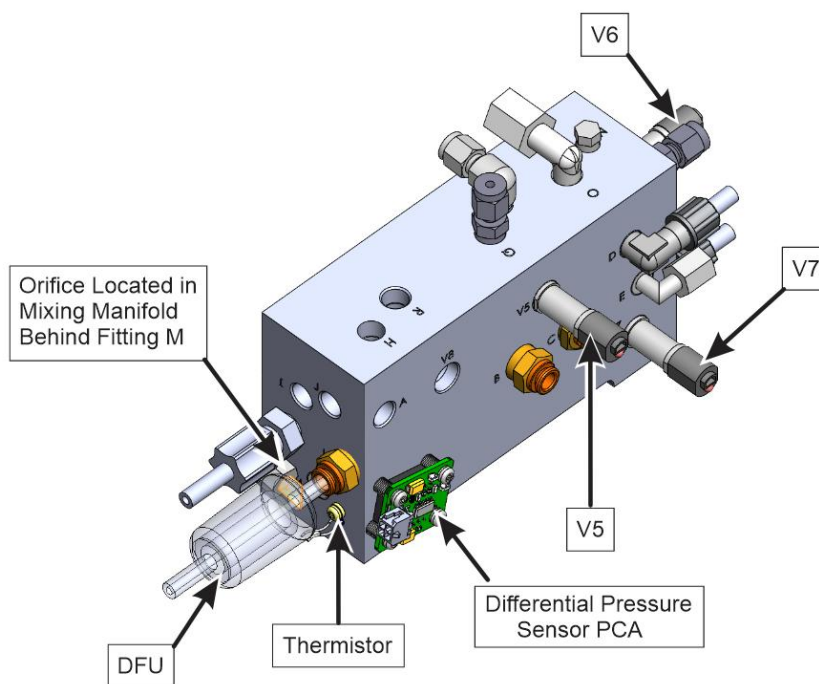

Figure 12 – Mixing Manifold Serinus Cal 2000

1.5.3.3 Pressure Regulator - Ozone Generator

Refer to Figure 10 for the location of pressure regulator. The pressure regulator is factory set to approximately 120 - 180 kPa. The pressure regulator maintains a constant pressure in front of a critical orifice to maintain the constant Ozone generator flow of 100 sccm. It is therefore equipped with a differential pressure sensor to display the Ozone flow on the home screen.

1.5.4 Serinus Cal 3000 Components

The Serinus Cal 3000 provides the Serinus Cal with both an Ozone generator and an Ozone photometer to measure the concentrations created. A feedback control algorithm allows the main controller PCA to adjust the output from the Ozone generator so that a precise concentration of Ozone is produced. This allows the Serinus Cal 3000 to be used as a transfer standard for calibration of Ozone analysers as well as performing a GPT for NO_x converter efficiency checks. The Serinus Cal 3000 has a number of additional changes to the Serinus Cal 2000 in order to incorporate the photometer function.

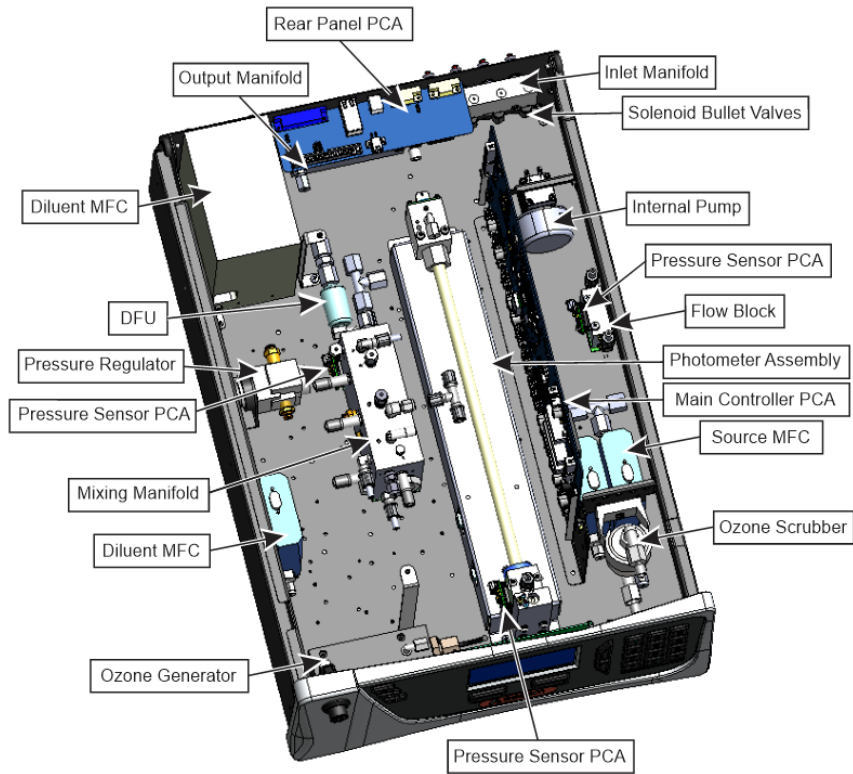

Figure 13 – Major Components of Serinus Cal 3000

1.5.4.1 Mixing Manifold (Serinus Cal 3000)

Refer to Figure 13 for the location of mixing manifold. This manifold contains the solenoid bullet valves, the Ozone mixing chamber and the Ozone flow pressure PCA. It also houses the orifice which controls the flow from the Ozone generator to the Ozone mixing chamber as well as an orifice for the photometer reference air flow. As the name of the manifold suggests all the gases pass through this manifold and mix to form the user defined gas concentration. If the point uses Ozone the mixing occurs in the mixing chamber. All the ports are labelled with letters A through to R to help identify them using the plumbing diagram (refer to Section 1.1).

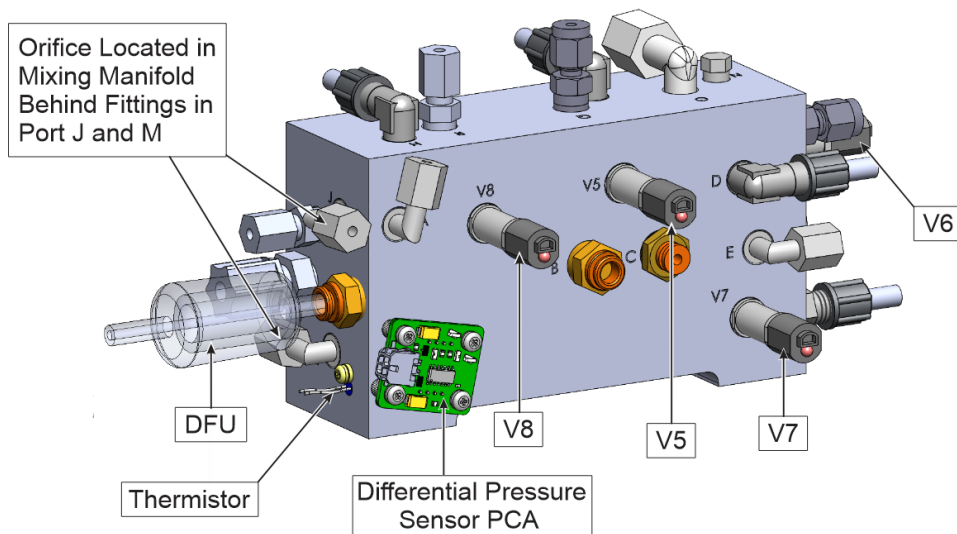

Figure 14 – Mixing Manifold Serinus 3000

1.5.4.2 Ozone Generator

Refer to Section 1.5.3.1 for details.

1.5.4.3 Pressure Regulator - Ozone Generator

Refer to Section 1.5.3.3 for details.

1.5.4.4 Internal Pump

Refer to Figure 13 for the location of internal pump. The internal pump draws a sample of generated Ozone from the output manifold, through the photometer assembly to be measured before scrubbing the Ozone and passing it out the exhaust port.

1.5.4.5 Flow Block

Refer to Figure 13 for the location of flow block. The flow block measures the downstream pressure created by the pressure drop caused by the internal pump and the critical orifice. The pump speed is controlled by the main controller PCA in order to maintain sufficient pressure drop across the critical orifice within the photometer assembly. This ensures that a stable photometer flow is maintained.

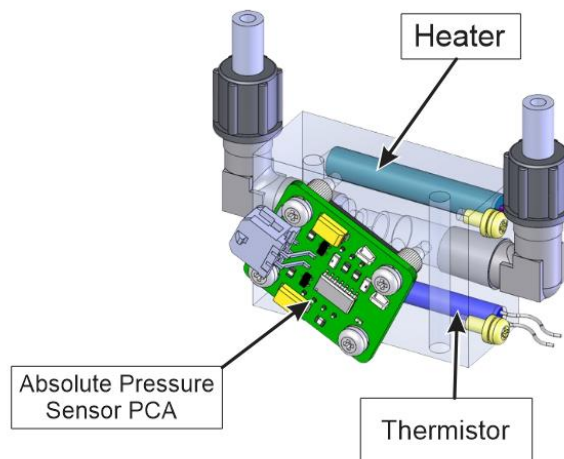

Figure 15 – Flow Block Assembly

1.5.4.6 Photometer Assembly

Refer to Figure 13 for the location of photometer assembly. The photometer assembly consists of an detector, detector PCA, measurement cell, orifice and sintered filter, UV lamp, heater and thermistor, pressure sensor PCA and lamp driver PCA. It is a non-dispersive ultraviolet (UV) photometer which switches between measuring Ozone from the output manifold and from the reference air. It calculates the ratio of transmitted light between the two signals providing an accurate and reliable measure of Ozone concentration.

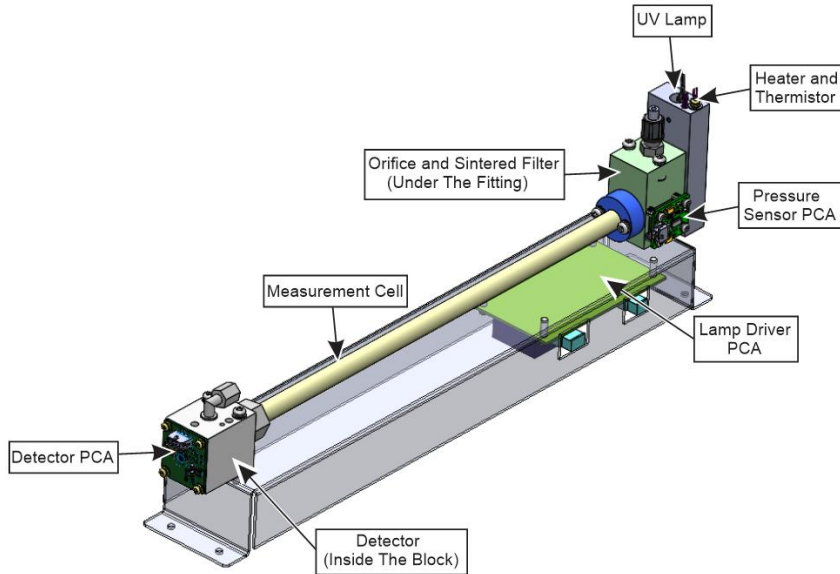

Figure 16 – Photometer Assembly

Measurement Cell

Refer to Figure 16 for the location of measurement cell. The measurement cell is a glass tube with a UV lamp at one end and a detector at the other. UV radiation is sequentially absorbed by sample air and Ozone free sample air over the length of the measurement cell. The remaining UV radiation reaching the detector is measured and used to calculate the O₃ concentration. The measurement cell is protected by a metal sheath.

Orifice and Sintered Filter

Refer to Figure 16 for the location of orifice and sintered filter. The critical orifice is made of a high precision stainless steel and sapphire, which is located under the sensor mounting block fitting. The critical orifice is a simple device that operates at a set temperature and requires minimal maintenance, it will passively keep the volume flow rate constant at a known value.

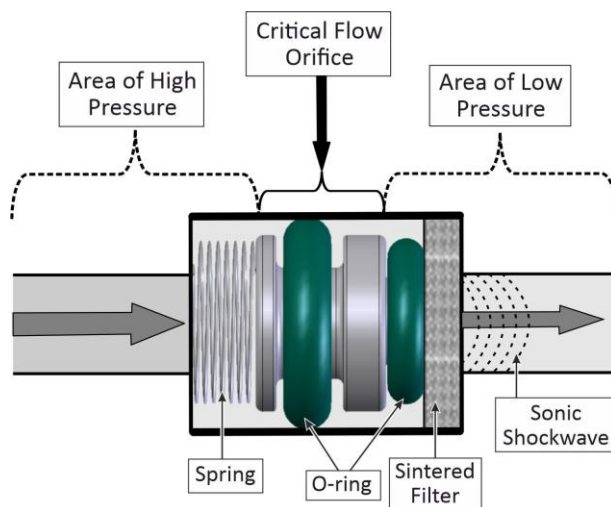

Figure 17 – Orifice and Sintered Filter

Detector

Refer to Figure 16 for the location of detector. The detector is a solar blind vacuum diode, sensitive only in the spectral region where O₃ absorbs UV light at 254 nm. This detector is used to monitor the intensity of the residual light after absorption in the measurement cell.

The detector PCA converts the UV light intensity into a voltage level which is processed by the instrument to calculate the O₃ concentration.

Heater and Thermistor

Refer to Figure 16 for the location of heater and thermistor. The heater and thermistor are mounted in the lamp housing on the UV lamp side of photometer assembly. They are used to keep the block temperature at a stable and constant 50 °C.

UV Lamp

Refer to Figure 16 for the location of UV lamp. UV lamp is used to produce UV light at 254 nm. It is powered by the lamp driver PCA.

Lamp Driver PCA

Refer to Figure 16 for the location of UV lamp. The lamp driver PCA is mounted under the photometer assembly. The lamp driver PCA generates a high-frequency voltage (800 - 1100 V) to start and maintain the UV lamp at a constant intensity. The UV lamp current is fixed at 10 mA.



CAUTION

The lamp driver PCA contains high voltages. Ensure instrument is turned OFF before accessing this component.

Note: The lamp driver PCA is the same type as used on the Serinus 50 SO₂ Analyser. For the Serinus Cal 3000 (which measures Ozone), with a REV D lamp driver PCA, set all the jumpers marked in red (JP1 - JP5) to the right (refer to Figure 18). The correct setting must be used or damage to the electronics may occur.

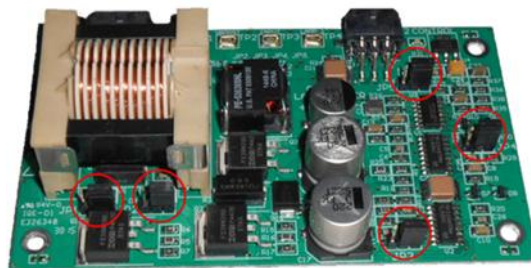

Figure 18 – Lamp Driver PCA Type Jumper Setting (REV D)

Pressure Sensor PCA

Refer to Figure 16 for the location of pressure sensor PCA. The pressure sensor PCA has an absolute-pressure transducer that is mounted to a block on the UV lamp side of the photometer assembly and sealed via a gasket. This allows the pressure sensor PCA to measure the sample air pressure in the measurement cell. This pressure reading is used to verify sample flow and correct measurement readings for pressure variations.

1.5.4.7 Ozone Scrubber

Refer to Figure 13 for the location of Ozone scrubber. The Ozone scrubber is used to eliminate the Ozone from the air to protect the internal pump. It uses manganese dioxide (MnO_2) as the catalyst to selectively eliminate Ozone.

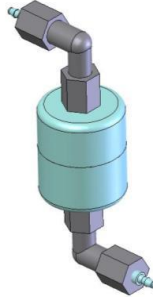

Figure 19 – Ozone Scrubber

This page is intentionally blank.

2. Installation

2.1 Initial Check

Packaging

The Serinus Cal 1000, 2000 & 3000 are transported in packaging which is specifically designed to minimise the effects of shock and vibration during transportation. Acoem recommends that the packaging be kept if there is a likelihood that the instrument is going to be relocated.

Note: The red plastic caps that seal the pneumatic connections during transport must be removed prior to operation.

Manual Handling

The Serinus Cal 1000, 2000 & 3000 weigh over 18 Kg. When lifting and carrying the instrument please follow these instructions to reduce the risk of injury:

- Two people are required to safely lift the instrument. One person to position their fingers under the front left and right corners, and the other person to position their fingers under the rear left and right corners of the instrument.
- If moving the instrument over longer distances, a suitable trolley should be used instead of manually carrying it.

Items Received

With the delivery of the Serinus Cal, the user will receive the following:

Table 3 – List of Items Received

Item Name	Part No.	Image
Acoem Serinus Cal 1000 instrument or Acoem Serinus Cal 2000 instrument or Acoem Serinus Cal 3000 instrument	E020301 or E020302 or E020303	Refer to Figure 20, callout 7.
Green Acoem Resources USB Stick	H030137-01	Refer to Figure 20, callout 10.
Manual (hardcopy optional)	M010056	-
USB Memory Stick	H030021	Refer to Figure 20, callout 9.
FQA Kit, Serinus Cal	H050080	Refer to Figure 20, callout 8.
Keys for Slam Lock	-	Refer to Figure 20, callout 11.
Data Sheet	-	Refer to Figure 20, callout 12.
Power Lead (120 V)*	C040007	Refer to Figure 20, callout 2.
Power Lead (240 V)*	C040006	Refer to Figure 20, callout 1.
	C040008	Refer to Figure 20, callout 3.

	C040009	Refer to Figure 20, callout 4.
	C040010	Refer to Figure 20, callout 5.
	C040054	Refer to Figure 20, callout 6.

*The power lead received depends on the power supply of the country (120 V or 240 V).

Note: Check that all these items have been delivered undamaged. If any item appears damaged, contact your supplier before turning the instrument ON.

Note: It is recommended to kept packaging material for transport or storage purpose.



Figure 20 – Received Items

Opening the Instrument

Check the interior of the instrument with the following steps:

1. Refer to Figure 21. Remove the thumb screws located on the rear panel.



Figure 21 – Opening the Instrument - 1

2. Refer to Figure 22. Unlocked the slam lock using keys provided with instrument.



Figure 22 – Opening the Instrument - 2

3. Refer to Figure 23. Open the chassis lid latch by pressing in the slam lock located on the front panel.



Figure 23 – Opening the Instrument - 3

4. Refer to Figure 24. To completely remove the lid, slide the lid backwards until the rollers line up with the gaps in the track and lift the lid upwards to remove from the instrument.



Figure 24 – Opening the Instrument - 4

5. Check that all pneumatic and electrical connectors are connected. If not, reconnect.
6. Check for any visible and obvious damage. If damage exists contact your supplier and follow the instructions in claims for Damaged Shipments and Shipping Discrepancies at the front of this manual.

2.2 Installation Notes

When installing the instrument, the following points must be taken into account:

- The calibrator should be placed in an environment with minimal dust, moisture and variation in temperature.
- For best results the calibrator should be located in a temperature and humidity-controlled environment (air-conditioned shelter). An enclosure temperature of 25 - 27 °C is optimum.
- Whether in a rack or placed on a bench, the instrument should not have anything placed on top of it or touching the case.
- Instruments should be sited with easy access to the front panel (instrument screen/USB memory stick and to the rear panel (communication ports/pneumatic connections).
- It is recommended that the pneumatic lines be as short as possible.
- When supplying calibration gas to other instruments through the output ports, ensure the flow is not pressurised and is sufficiently vented to ambient pressure.

Note: The power ON/OFF switch is accessible from the rear of the instrument only. Site the calibrator so that the ON/OFF power switch is accessible.

2.3 Instrument Set-up

After unpacking the instrument, the following procedures should be followed to ready the calibrator for operation.

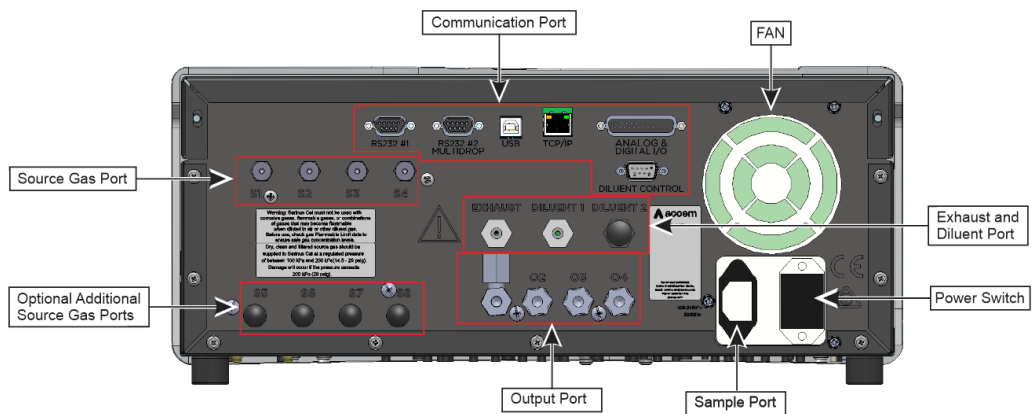

Figure 25 – Serinus Cal Rear Panel

2.3.1 Setting-up a Serinus Cal

1. Connect gas cylinder standard(s) to source ports **S1 - S4**.
2. Connect clean zero air source to **Diluent Port(s) 1**.
3. Connect communication cable(s).
4. Connect the output ports **O2 - O4** to test analysers. **Plug unused ports.**
5. Connect tubing to the output port **O1** and vent end of line away to atmosphere.
6. Refer to Figure 26. Open the lid and ensure the USB memory stick is installed.



Figure 26 – Installation of USB Memory Stick

7. Refer to Figure 27. Check the battery is turned ON at the main controller PCA.

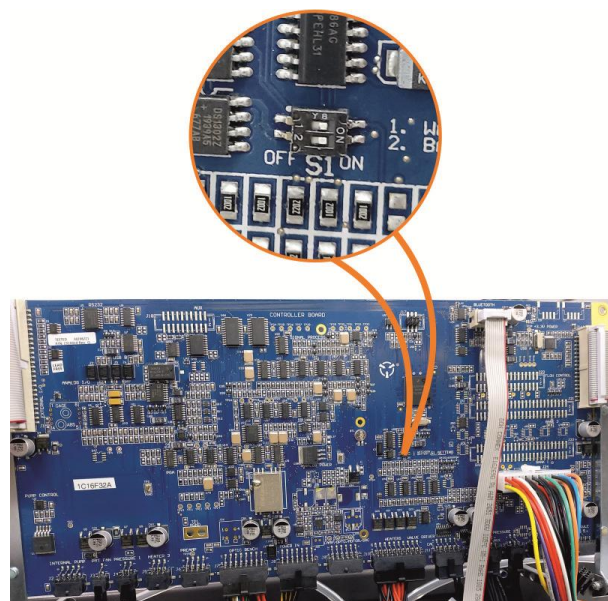

Figure 27 – Switching the Battery ON/OFF

8. Turn ON the instrument and allow the warm-up procedure to complete (refer to Section 3.1).
9. Set the internal data logging options (refer to Section 3.5.37).
10. Check/set time and date (refer to Section 3.5.21).
11. Program the instrument for your gas standard concentrations and points (refer to Section 3.5.5 and Section 3.5.9).
12. Program the instrument for your required sequences if used (refer to Section 3.5.11). Configure the analog input and output settings and digital outputs settings if used (refer to Section 3.5.38).
13. Set the communication parameters to your chosen communication method (refer to Section 3.5.36).
14. The instrument is now ready to be operated.

2.3.2 Setting-up a Serinus Cal 3000

In the case of a Serinus Cal 3000, please follow the steps 1 - 14 from Section 2.3.1 and then proceed with the following steps:

1. To ensure consistent pressure while using the Serinus Cal 3000 the exhaust port and one of the output ports must be connected together and run to the exhaust (refer to Figure 28).

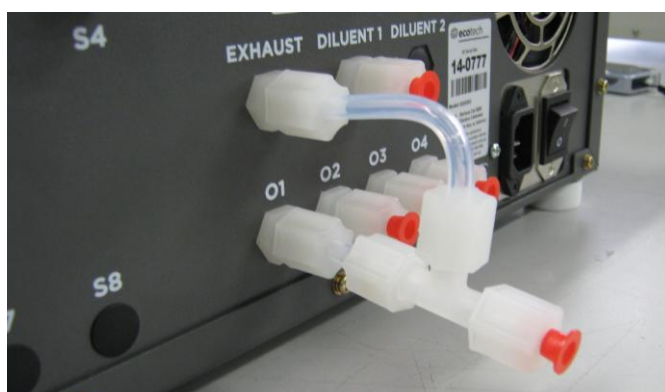

Figure 28 – Connecting the Output and Exhaust Ports Serinus Cal 3000 Only

2. Let the instrument warm-up and stabilise for 2 - 3 hours before operation.
3. The instrument is now ready to be operated.

2.3.3 Power Connections



CAUTION

Hazardous voltages exist within the instrument. Do not remove or modify any of the internal components or electrical connections whilst the mains power is ON.



CAUTION

Always unplug the equipment prior to removing or replacing any components.



CAUTION

Do not replace the detachable mains supply cord with an inadequately rated cord. Any mains supply cord that is used with the instrument must comply with the safety requirements (250 V/10 A minimum requirement).



CAUTION

Ensure that the mains supply cord is maintained in a safe working condition.



CAUTION

When connecting the mains power to the instrument, the following must be adhered to otherwise the safety and the reliability of the instrument may be compromised.

- A three pin mains power lead with a protective earth conductor **MUST** be used.
- The mains power outlet (wall socket) must be in the range of 100 - 240 VAC, 50 - 60 Hz.
- The mains power outlet must be protected by an earth leakage protection circuit.
- Refer to Figure 29. Connect the instrument's power cord into the instrument and mains power outlet.



Figure 29 – Connect Power Cord

- Refer to Figure 30. Turn ON the power switch.

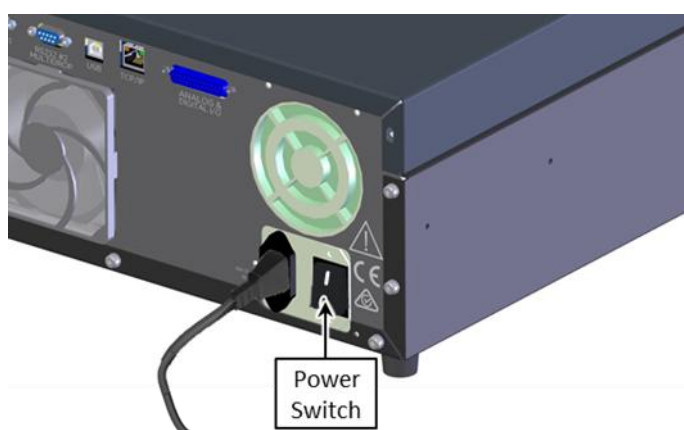

Figure 30 – Turn ON Power Switch

2.3.4 Pneumatic Connections

The Serinus Cal 1000, 2000 & 3000 feature several pneumatic ports on the rear panel; the source gases ports, the output ports, the diluent port(s) and the exhaust port. The number of ports depends on the Serinus Cal model and its installed options. All tubing and fittings used should follow the instructions below:

1. Must be made of Teflon® FEP material, Kynar®, stainless steel, glass or any other suitably inert material.
2. Calibration lines should be kept to a minimum length.
3. Exhaust line for the 3000 should be about 2 meters in length with ID, ¼ inch. If longer is required, use ID 3/8 inch.
4. Tubing must be cut squarely and any burrs removed.

Procedure

1. Refer to Figure 31. Remove all the dust plugs.



Figure 31 – Dust Plugs

2. Refer to Figure 32. Remove the Inlet manifold SS nut.



Figure 32 – Remove Nut

3. Connect the tubing, refer the Section 2.3.5 for the procedure.
4. Nuts should be re-tightened when instrument reaches operating temperature.

2.3.5 Fitting Procedure

2.3.5.1 1/8T Swagelok Fitting

Note: If the ferrules have been pre-swaged the user will only need to nip up the nut 1/10 turn.

1. Insert the tubing into the nut ensuring the ferrules are in the correct position



Figure 33 – Ferrule Correct Position

2. Push the tubing as far as you can into the fitting and then fully tighten the nut with fingers.



Figure 34 – Tighten Nut with Finger

3. Mark the nut at the 12 o'clock position with a black marker.
4. Swage (tighten) the nut 3/4 turn ensuring you finish at the 9 o'clock position.

2.3.5.2 1/4T Plastic Kynar Nut

1. Insert the tubing into the nut ensuring the two ferrules are in the correct position and are facing the right direction.



Figure 35 – Ferrule Correct Position

2. Push the tubing as far as you can into the fitting and then fully tighten the nut with fingers.



Figure 36 – Tighten Kynar Nut with Finger

3. Tighten the nut 3/4 turn.
4. Ensure you cannot easily undo the nut with your fingers.

2.3.6 Diluent Gas

The Serinus Cal features a diluent port which is typically a clean, unreactive gas used to dilute span gas.

The diluent gas will be mixed with a source gas in order to achieve the user-defined concentration. An optional second diluent port can also be setup for varied applications (Diluent 2, Figure 25).

The user can define the following diluent gases as alternatives to **AIR**; NH₃, CO, CO₂, CH₄, H₂S, NO, NO₂, N₂, SO₂, C₂H₆, C₃H₈, C₄H₁₀, HE, O₂ and O₃.

Note: When generation a point that uses the Ozone generator, AIR must be connected to the diluent port in Serinus Cal 2000 and 3000, as this diluent is used to generate Ozone and as a reference gas for the photometer.

Selecting a different diluent gas automatically changes the mass flow correction factor.



CAUTION

Dry, clean and filtered source gas should be supplied to Serinus Cal at a regulated pressure of between 100kPa and 200kPa (14.5 - 29 psig). Damage still occurs if the pressure exceeds 200kPa (29 psig).

2.3.7 Source Gas

The gas standards connect via the source gas port(s), labelled S1 to S4 (refer to Figure 25). Dry, clean and filtered source gas should be supplied to the Serinus Cal at a regulated pressure of between 100 - 200 kPa.

1/8" stainless steel tubing should be used with the supplied fittings. Only 3/4 of a turn is required after finger tightening the nut. Serious damage may result from over-tightening.

An optional second inlet manifold can also be added in order to increase the number of source gases to 8 (ports **S5-S8**, refer to Figure 25).



WARNING

Do not supply flammable gas mixtures to the Serinus Cal. The MFC's use an internal heated element which has the potential to cause an explosion. Particular attention should be paid to Hydrogen, Oxygen and Methane source gases.

2.3.8 Output Ports

There are four output gas ports available on the Serinus Cal, labelled O1 to O4. Diluted source gas is sent to each of the four output ports. Chemically inert Kynar fittings have been used and should be finger tight only. If any of the output ports are not used, they should be sealed with the supplied Kynar nut. One of the output ports must be connected to vent in order to avoid pressurising the unit. Damage to the equipment may occur if the output pneumatic system is pressurised.



CAUTION

One of the output ports must be connected to the vent in order to avoid pressuring the unit.

2.3.9 Exhaust Port

The exhaust port is where the output of the purge valve is connected as well as the output of the Ozone generator when it is not in use. In the case of the Serinus Cal 3000, the exhaust of the internal photometer pump is connected to this port (refer to Figure 28). The exhaust port must be connected to an exhaust manifold venting to a suitable location outside the room and away from the sample inlets of gas analysers in the system.

2.3.10 Purge for Gas Lines

The calibrator includes a purge option that allows venting of gases without the danger of contaminating other gas standards. Default setting is OFF but with this firmware option enabled, gases are purged for a set period of time out the exhaust port or whenever a source gas is changed (user defined).

If the optional second source MFC is installed, one of the source ports (S4) is used as the purge port. In this situation the source port (S4) should be externally connected to the exhaust port.



CAUTION

It is recommended that exhaust air is not expelled into a shelter/room inhabited by people. It should be expelled into the external air with sufficient distance away from the sample inlet of gas analysers.

2.3.11 Communications Connections

There are a number of ways to communicate with the instrument, refer to Section 4 for detail.

2.4 Transporting/Storage

Transporting the Serinus Cal should be done with great care. It is recommended that the packaging the Serinus Cal was delivered in should be used when transporting or storing the instrument.

When transporting or storing the instrument the following points should be followed:

1. Turn OFF the instrument and allow it to cool down.
2. Remove all pneumatic, power and communication connections.
3. Refer to Figure 27. If storing over a long period (6 months) turn the battery OFF by switching the switch (S1) on the main controller PCA to OFF.
4. Remove the instrument from the rack.
5. Refer to Figure 37. Seal each pneumatic ports with a dust plug.



Figure 37 – Dust Plugs

6. Refer to Figure 26. Remove the USB memory stick and pack with instrument.
7. Place the instrument back into a plastic bag with desiccant packs and seal the bag (ideally the bag it was delivered in).
8. Refer to Figure 38. Place the instrument back into the original foam and box it was delivered in. If this is no longer available find some equivalent packaging which provides protection from damage.

Note: Acoem recommended to use the same packing material in which instrument is delivered.

9. The instrument is now ready for long term storage or transportation.

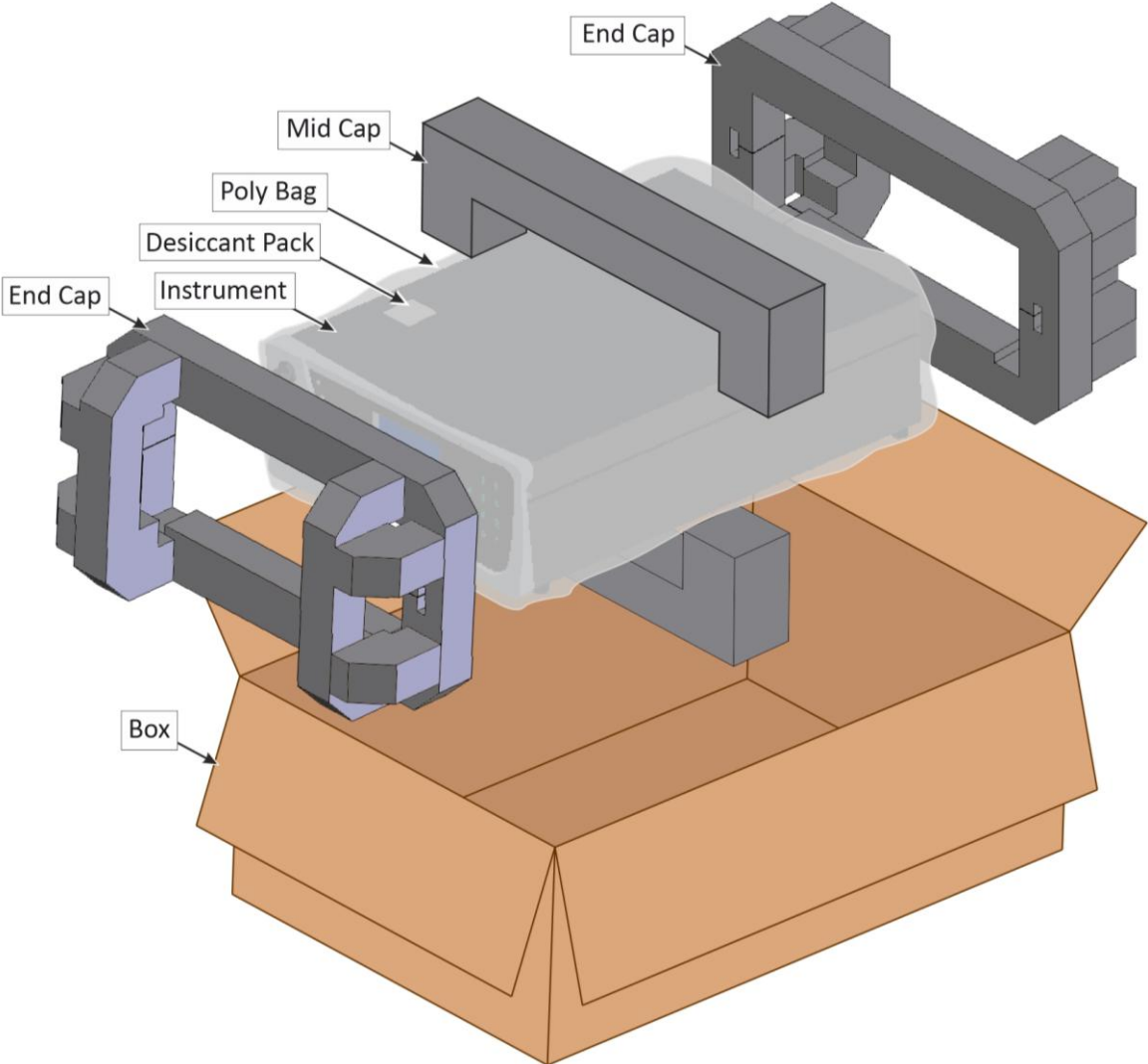

Figure 38 – Packing Instruction

3. Operation

3.1 Warm-Up

No warm up period is required for Serinus Cal 1000 or 2000, both calibrators are ready to begin operation immediately. It is suggested to allow the instrument to warm up for one hour, allowing the instrument to stabilise to the surrounding environment for best results.

The photometer portion of the Serinus Cal 3000 requires a warm up period before it can execute a photometer point. During this period, the instrument will adjust itself to prepare for monitoring. Other functions are available immediately at start up.

The following activities occur during Serinus Cal 3000 warm-up:

Lamp Adjust

The instrument automatically adjusts the lamp's current (10 mA) for a stable (reference voltage) signal/output (2 minutes).

Ref Stabilise

The instrument sets the reference voltage to 2.8 - 3.2 V output and waits for a stable output signal.

Zero Adjust

The instrument sets the course and fines zero pots for a zero-detector output.

Zero Stabilise

The instrument waits until the zero voltage signals are stable.

After this warm-up has completed the Serinus Cal 3000 can execute photometer points.

3.2 Theory of Operation

The Serinus Cal operates by using diluent gas definition, gas standard definitions, points and sequences.

When setting up the Serinus Cal for the first time the user will need to first define the gas standards that they will be connecting to the instrument via the source ports and the diluent gas via the diluent port. This needs to be done before any points or sequences can be defined.

There are 4 source ports (standard) but the user can define up to 10 gas standards definitions within the instrument.

There is 1 diluent port (standard) this should be configured to match the gas connected to the diluent port.

From the gas standard definitions points can be defined. A point is a user-defined configuration of gas flows. Up to 64 points can be defined and named. Each point can perform a different operation (gas dilution, zero-point, source control etc.), utilizing different diluent gas, gas standards, flows, and concentrations.

A sequence is a series of points. Up to 16 sequences can be defined. Each sequence can run up to 16 points for a user-specified amount of time. Sequences can also run other sequences as one of their actions, allowing for very complex series of points to be executed. The nesting of sequences can only go three deep before the user will get a nesting error. To signify the end of a sequence the user can select the repeat or idle action, which will repeat the sequence or place the Serinus Cal into Idle.

Points or sequences can be initiated from the **Quick Menu → Mode**, or they can be initiated remotely via digital inputs or serial commands.

For convenience there is a “Manual” point. This is exactly like a point definition except it does not occupy one of the 64 named point definitions. It is useful for operating the machine in an immediate mode where flow and concentration changes can be done on the fly. Points created in manual mode can be copied to a point number and given a name when the user wants to keep it long term and is satisfied.

3.2.1 Running a Point or Sequence

Initially the Serinus Cal requires several steps to be followed in order to run an automatic point or sequence.

- Program your gas cylinder concentrations and diluent gas in the **Gas Supply Menu**
- Program points in the **Points & Sequencing Menu**
- Program sequences (if applicable) in the **Points & Sequencing Menu**
- Start the desired point or sequence by accessing the **Quick Menu → Mode** and selecting point or sequence

3.2.2 Operation

When defining a point, the user first need to select an operation. Each of the Serinus Cal models has a different number of operations available to the user. The Serinus Cal 1000 has three operations, Gas Dilution, Zero Point and Source Control. The Serinus Cal 2000 has five operations, Gas Dilution, Zero Point, Source Control, Titration and O3 Generator. The Serinus Cal 3000 has six operations, Gas Dilution, Zero Point, Source Control, Titration, O3 Generator and O3 Gen/Photometer. The following sections give examples of each type of operation and how set them up.

3.2.2.1 Gas Dilution

Step by Step Example:

1. Open - **Main Menu → Gas Supply Menu → Edit Gas Standards Menu**.
2. Edit - **Standard 1** - (Refer to your gas cylinder certificate and input gas types, concentrations and units for each gas component within the cylinder).

Note: Not all fields within the Edit gas standard menu are mandatory. Such as serial number and expiration date. **Serial No.** and **Expiration** are information fields for your gas cylinder. **Balance Gas** is typically N2 and will be stated on your gas cylinder certificate.

3. Edit - **Name** - (give the Gas Standard a name that will help distinguish it from the others, for this example we will be using “Examp1”) - Accept.
4. Edit - **Serial No.** - (as stated on the certificate) - Accept.
5. Edit - **Expiration** - (as stated on the certificate) - Accept.

6. Select - **Balance Gas** - (as stated on the certificate) - Accept.
7. Select - **Gas 1** - (as stated on the certificate) - Accept.

Note: When the user select the **Gas 1** and change it from **None** to a gas name it will give the user to option of editing a second component gas. This allows the user to enter up to six gases in one gas standard.

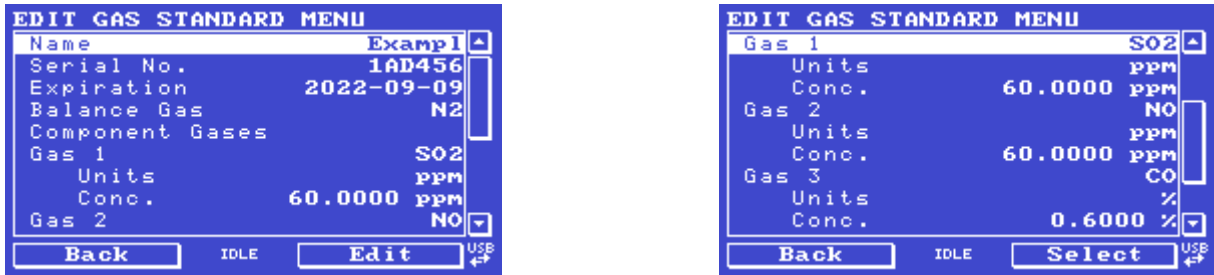

Figure 39 – Edit Gas Standard Menu (Example 1)

8. Return to the **Gas Supply Menu** (press back twice).
9. Select - **Diluent Port 1** - (change from **None** to the gas physically connected to the diluent port, typically **AIR**).

Note: Once a gas standard is defined the user needs to link the gas standard definition to the physical connection of the gas cylinder on the source ports (located on the rear of the instrument).

10. Connect the cylinder to one of the Source ports. (for this example, the cylinder is connected to source port 1 (**S1**))
11. Select - **Source Port 1** - (choose the gas standard that was just defined, “Examp1”) - Accept.



Figure 40 – Gas Supply Menu (Example 1)

12. Return to the **Home Screen** (the user can press the bottom status light (green)).

Note: Now that the **Gas Standard** and the **Diluent** have been defined, the **Point** can be defined. There are some menu items that will not be used in the steps, an explanation is given at the end of the example. **Define Point Menu** has 64 available programmable points.

13. Open - **Main Menu** → **Points & Sequencing Menu** → **Define Points Menu**.
14. Edit - **Point 1**.
15. Edit - **Name** - (give the point a name that will help distinguish it from the others, for this example we will be using “EXE 01”) - Accept.
16. Select - **Operation - Gas Dilution** - Accept.

17. Edit - **Flow** - (Set the flow rate to slightly above the instruments' requirements and connect them to the output manifold. Excess flow will be vented, as insufficient flow may cause undesirable results.) - Accept.
18. Select - **Diluent** - (set to the gas required to dilute the source gas, typically **AIR**) - Accept.
19. Select - **Standard** - (choose the gas standard the user wishes to dilute, for this example we will select "Exempl") - Accept.
20. Select - **Gas** - (this will give the user a list of the gas components within the cylinder, for this example we will select "SO₂") - Accept.
21. Select - **Units** - (this will be the units that are displayed for all the gas components in the cylinder on the home screen, for this example we will select "ppm") - Accept.
22. Edit - **Set Point** - (enter in the value of the final diluted concentration that will be supplied to the instruments connected to the output manifold. For the example we will use "0.4000 ppm").

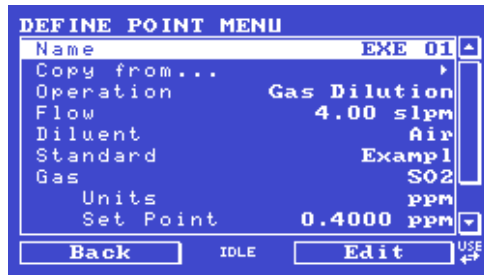

Figure 41 – Gas Dilution Point Setup (Example 1)

23. Return to the **Home Screen** (the user can press the bottom status light (green)).
24. This Point is now configured correctly and can be started automatically (via serial commands or digital bits) or manually (via the **Quick Menu**). In the case of multiple gases, the home screen will calculate and display the diluted concentrations for each gas component defined in the Gas Standard.
25. Open - **Quick Menu**.
26. Select - **Mode - Point** - Accept - **EXE 01** - Accept.
27. Return to the **Home Screen** (the user can press the bottom status light (green)).

Note: Figure 42 shows the Home Screen with all the gas components within the Gas Standard displaying their new diluted concentration values in ppm units. At the top we can also see the Serinus Cal automatically controlling the dilution and source flow to give the user their total flow requested in the point definition.

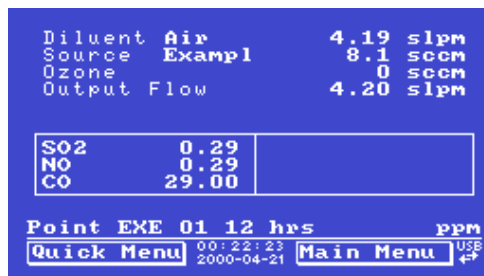

Figure 42 – Home Screen Running EXE 01 Point

Note: Some of the menu items in the **Define Point Menu** that were not discussed were the 'Copy From...', 'Input Mask' and 'Output Mask'. The 'Copy From...' feature can be used make quick copies of existing points that are similar or that were developed in **Manual Point Menu**. The 'Input Mask' and 'Output Mask' relate to the two lots of eight digital bits that can be used to automatically start points (digital input) and give a digital output to give an indication or control other instruments or relays (digital output).

3.2.2.2 Zero Point

Step by Step Example:

1. Open - **Main Menu** → **Gas Supply Menu**
2. Select - **Diluent Port 1** - (change from **None** to the gas physically connected to the diluent port, typically **AIR**).
3. Return to the **Home Screen** (the user can press the bottom status light (green)).

Note: Now that the **Diluent** has been defined, the **Point** can be defined. There are some menu items that will not be used in the steps, an explanation is given at the end of the example. **Define Point Menu** has 32 available programmable points.

4. Open - **Main Menu** → **Points & Sequences Menu** → **Define Points Menu**.
5. Edit - **Point 2**.
6. Edit - **Name** - (give the point a name that will help distinguish it from the others, for this example we will be using "EXE 02") - Accept.
7. Select - **Operation - Zero Point** - Accept (the flow will default to the lowest flow possible, typically 0.50 slpm).
8. Edit - **Flow** - (set to the flow to the value required for the instruments connected to the output manifold, for this example we will set it to 5.0 slpm) - Accept.
9. Select - **Diluent** - (change to gas required for zero point, typically **AIR**) - Accept.



Figure 43 – Zero Point Setup

10. Return to the **Home Screen** (the user can press the bottom status light (green)).
11. This Point is now configured correctly and can be started automatically (via serial commands or digital bits) or manually (via the **Quick Menu**).
12. Open - **Quick Menu**.
13. Select - **Mode - Point** - Accept - **EXE 02** - Accept.

Note: Figure 44 shows the Home Screen with the Serinus Cal automatically controlling the dilution flow to give the user their total flow requested in the point definition.

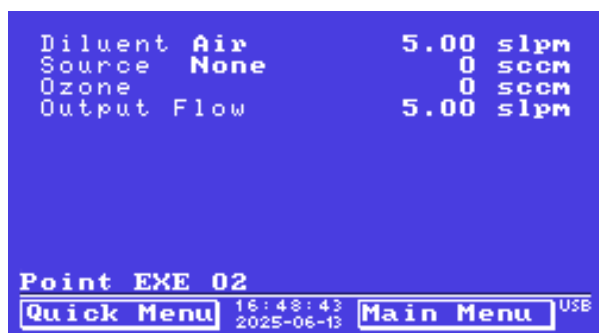

Figure 44 – Home Screen Running EXE 02 Point

Note: Some of the menu items in the **Define Point Menu** that were not discussed were the “Copy From...”, “Input Mask” and “Output Mask”. The “Copy From...” feature can be used make quick copies of existing points that are similar or that were developed in **Manual Point Menu**. The “Input Mask” and “Output Mask” relate to the two lots of eight digital bits that can be used to automatically start points (digital input) and give a digital output to give an indication or control other instruments or relays (digital output).

3.2.2.3 Source Control

Step by Step Example:

1. Open - **Main Menu** → **Gas Supply Menu** → **Edit Gas Standards Menu**.
2. Edit - **Standard 1** - (Refer to your gas cylinder certificate and input gas types, concentrations and units for each gas component within the cylinder).

Note: Not all fields within the Edit gas standard menu are mandatory. Such as serial number and expiration date. **Serial No.** and **Expiration** are information fields for your gas cylinder. **Balance Gas** is typically N2 and will be stated on your gas cylinder certificate.

3. Edit - **Name** - (give the Gas Standard a name that will help distinguish it from the others, for this example we will be using “Examp1”) - Accept.
4. Edit - **Serial No.** - (as stated on the certificate) - Accept.
5. Edit - **Expiration** - (as stated on the certificate) - Accept.
6. Select - **Balance Gas** - (as stated on the certificate) - Accept.
7. Select - **Gas 1** - (as stated on the certificate) - Accept.

Note: When the user select the **Gas 1** and change it from **None** to a gas name it will give the option of editing a second component gas. This allows the user to enter up to six gases in one gas standard.

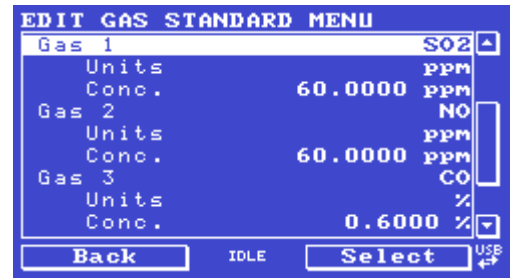

Figure 45 – Edit Gas Standard Menu (Example 3)

- Return to the **Home Screen** (the user can press the bottom status light (green)).

Note: Now that the **Gas Standard** has been defined, the **Point** can be defined. There are some menu items that will not be used in the steps, an explanation is given at the end of the example. **Define Point Menu** has 64 available programmable points.

- Open - **Main Menu** → **Points & Sequences Menu** → **Define Points Menu**.
- Edit - **Point 3**.
- Edit - **Name** - (give the point a name that will help distinguish it from the others, for this example we will be using "EXE 03") - Accept.
- Select - **Operation - Source Control** - Accept.
- Edit - **Flow** - (set to the flow to the value required for the instruments connected to the output manifold, for this example we will set it to 40 sccm) - Accept.
- Select - **Standard** - (choose the gas standard the user wishes to run, for this example we will select "Exempl") - Accept.
- Select - **Gas** - (this will give the user a list of the gas components within the cylinder, for this example we will select "SO2") - Accept.
- Select - **Units** - (this will be the units that are displayed for all the gas components in the cylinder on the home screen, for this example we will select "ppm") - Accept.

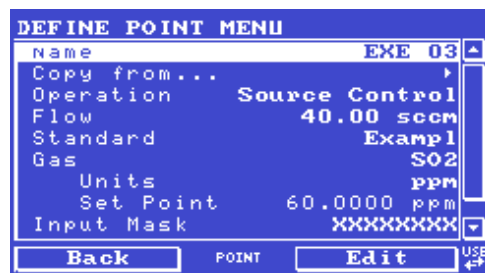

Figure 46 – Source Control Setup

- Return to the **Home Screen** (the user can press the bottom status light (green)).
- This Point is now configured correctly and can be started automatically (via serial commands or digital bits) or manually (via the **Quick Menu**).
- Open - **Quick Menu**.
- Select - **Mode - Point** - Accept - **EXE 03** - Accept.

Note: Figure 47 shows the Home Screen with all the gas components within the Gas Standard displaying their concentration. The Serinus Cal automatically controls the Source flow to give the user their total flow requested in the point definition.

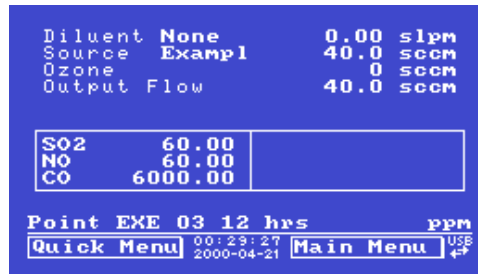

Figure 47 – Home Screen Running EXE 03 Point

Note: Some of the menu items in the **Define Point Menu** that were not discussed were the ‘Copy From...’, ‘Input Mask’ and ‘Output Mask’. The ‘Copy From...’ feature can be used make quick copies of existing points that are similar or that were developed in **Manual Point Menu**. The ‘Input Mask’ and ‘Output Mask’ relate to the two lots of eight digital bits that can be used to automatically start points (digital input) and give a digital output to give an indication or control other instruments or relays (digital output).

3.2.2.4 Titration (Serinus Cal 2000, 3000)

Step by Step Example:

1. Open - **Main Menu** → **Gas Supply Menu** → **Edit Gas Standards Menu**.
2. Edit - **Standard 1** - (Refer to your gas cylinder certificate and input gas types, concentrations and units for each gas component within the cylinder).

Note: Not all fields within the Edit gas standard menu are mandatory. Such as serial number and expiration date. **Serial No.** and **Expiration** are information fields for your gas cylinder. **Balance Gas** is typically N2 and will be stated on your gas cylinder certificate.

3. Edit - **Name** - (give the Gas Standard a name that will help distinguish it from the others, for this example we will be using “Exempl”) - Accept.
4. Edit - **Serial No.** - (as stated on the certificate) - Accept.
5. Edit - **Expiration** - (as stated on the certificate) - Accept.
6. Select - **Balance Gas** - (as stated on the certificate) - Accept.
7. Select - **Gas 1** - (as stated on the certificate) - Accept.

Note: When the user select the **Gas 1** and change it from **None** to a gas name it will give the option of editing a second component gas. This allows the user to enter up to six gases in one gas standard.

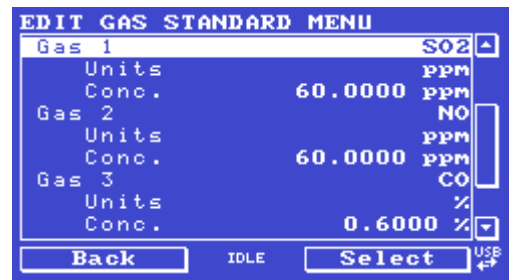

Figure 48 – Edit Gas Standard Menu (Example 4)

8. Return to the **Gas Supply Menu** (press back twice).
9. Select - **Diluent Port 1** - (change from **None** to the gas physically connected to the diluent port, typically **AIR**. When using the Titration operation the user must select a diluent that contains sufficient oxygen so the Ozone generator can produce Ozone).

Note: Once a gas standard is defined the user needs to link the gas standard definition to the physical connection of the gas cylinder on the source ports (located on the rear of the instrument).

10. Connect the cylinder to one of the Source ports. (for this example, the cylinder is connected to source port 1 (**S1**))
11. Select - **Source Port 1** - (choose the gas standard that was just defined, “Exempl”) - Accept.



Figure 49 – Gas Supply Menu (Example 4)

12. Return to the **Home Screen** (the user can press the bottom status light (green)).

Note: Now that the **Gas Standard** and the **Diluent** have been defined, the **Point** can be defined. There are some menu items that will not be used in the steps, an explanation is given at the end of the example. **Define Point Menu** has 64 available programmable points.

13. Open - **Main Menu** → **Points & Sequences Menu** → **Define Points Menu**.
14. Edit - **Point 4**.
15. Edit - **Name** - (give the point a name that will help distinguish it from the others, for this example we will be using “EXE 04”) - Accept.
16. Select - **Operation - Titration** - Accept.
17. Edit - **Flow** - (set to the flow to the value required for the instruments connected to the output manifold. For this example, we will use 5.0 slpm) - Accept.
18. Select - **Diluent** - (set to the gas required by the user to dilute the source gas, typically **AIR**) - Accept.
19. Select - **Standard** - (choose the gas standard the user wishes to dilute, for this example we will select “Exempl”) - Accept.

20. Select - **Gas** - (this will give the user a list of the gas components within the cylinder, for this example we will select “NO”) - Accept.
21. Select - **Units** - (this will be the units that are displayed for all the gas components in the cylinder on the home screen, for this example we will select “ppm”) - Accept.
22. Edit - **Set Point** - (enter in the value of the final diluted concentration that will be supplied to the instruments connected to the output manifold. For the example we will use “0.4000ppm”) - Accept.
23. Off - **Zero Point** - Off (this will allow the Ozone generator to produce Ozone)
24. Select - **Units** - (this will not have an impact on the home screen units, so we suggest selecting the units that are most relevant for the concentration set point the user is requesting. For this example, we will select “ppm”) - Accept.
25. Edit - **Set Point** - (this is where the user can set the concentration required from the Ozone Generator. For this example, we will select “0.3500ppm”) - Accept.

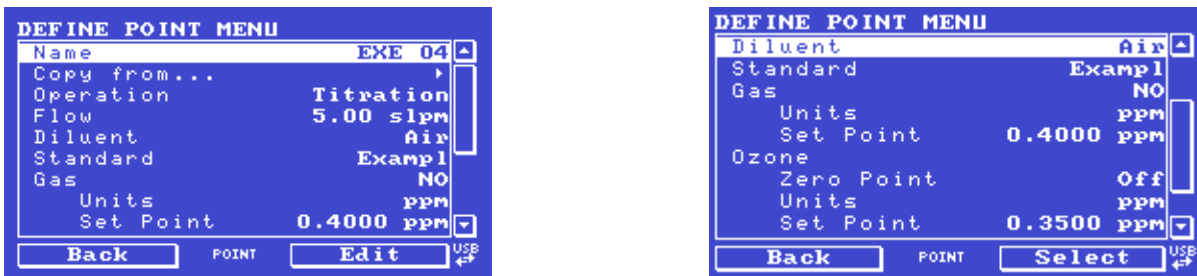

Figure 50 – Titration Setup, with Ozone

26. Return to the **Home Screen** (the user can press the bottom status light (green)).
27. This Point is now configured correctly and can be started automatically (via serial commands or digital bits) or manually (via the **Quick Menu**).
28. Open - **Quick Menu**.
29. Select - **Mode** - Point - Accept - EXE 04 - Accept.

Note: Figure 52 shows the Home Screen with all the gas components within the Gas Standard displaying their new diluted concentration values as well as the Ozone concentration from the Ozone generator all concentrations are in ppm units. At the top we can also see the Serinus Cal automatically controlling the dilution, source and Ozone flow to give the user their total flow requested in the point definition.

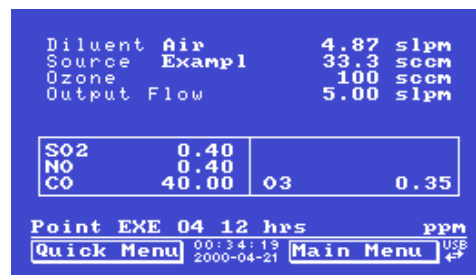

Figure 51 – Home Screen Running EXE 04 Point

Note: The main reason for running a titration point is to perform a GPT (gas phase titration). When we do a GPT we run a point with NO and O₃ and then without affect any of the concentrations or flow we stop running Ozone (run a zero point of Ozone). This can be done manually by turning the zero point menu item ON and OFF in the titration point setup. If the user wanted this to be automatic they need to set up another point identical to this point but without any Ozone (Ozone zero point set to ON). They can then be triggered with individual digital input bits or serial commands or used in a sequence.

30. Open - **Main Menu** → **Points & Sequences Menu** → **Define Points Menu**.
31. Edit - **Point 5**.
32. Edit - **Name** - (give the point a name that will help distinguish it from the others, for this example we will be using "EXE 05") - Accept.
33. Copy - **Copy from...** - EXE 04 - Accept.
34. On - **Zero Point** - On.

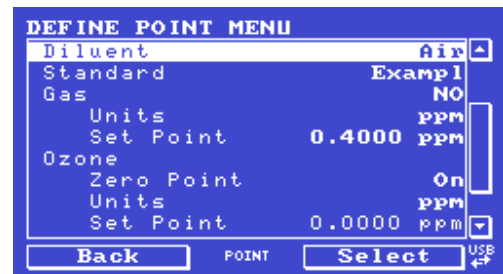
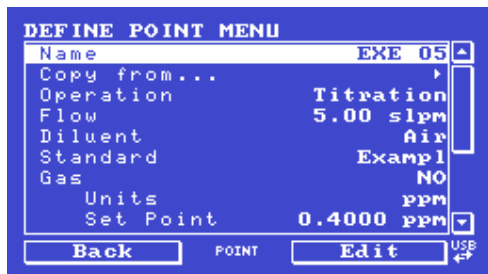

Figure 52 – Titration Setup, without Ozone

35. Return to the **Home Screen** (the user can press the bottom status light (green)).
36. This second Point is now configured correctly and can be started automatically (via serial commands or digital bits) or manually (via the **Quick Menu**) to give the user the same total flow and same concentration of NO but without the Ozone.
37. Open - **Quick Menu**.
38. Select - **Mode** - Point - Accept - EXE 05 - Accept.

Note: Figure 53 shows the Home Screen with all the gas components within the Gas Standard displaying their new diluted concentration values as well as the zero Ozone concentration from the Ozone generator. All concentrations are in ppm units. At the top we can also see the Serinus Cal automatically controlling the dilution, source and Ozone flow to give the user their total flow requested in the point definition.



Figure 53 – Home Screen Running EXE 05 Point

Note: Some of the menu items in the **Define Point Menu** that were not discussed were the 'Input Mask' and 'Output Mask'. The 'Input Mask' and 'Output Mask' relate to the two lots of eight digital bits that can be used to automatically start points (digital input) and give a digital output to give an indication or control other instruments or relays (digital output).

3.2.2.5 O3 Generator (Serinus Cal 2000, 3000)

Step by Step Example:

1. Open - **Main Menu** → **Gas Supply Menu**.
2. Select - **Diluent Port 1** - (change from **None** to the gas physically connected to the diluent port, typically **AIR**. When using the O3 Generator operation the user must select a diluent that contains sufficient oxygen so the Ozone generator can produce Ozone).
3. Return to the **Home Screen** (the user can press the bottom status light (green)).

Note: Now that the **Diluent** has been defined, the **Point** can be defined. There are some menu items that will not be used in the steps, an explanation is given at the end of the example. **Define Point Menu** has 64 available programmable points.

4. Open - **Main Menu** → **Points & Sequences Menu** → **Define Points Menu**.
5. Edit - **Point 6**.
6. Edit - **Name** - (give the point a name that will help distinguish it from the others, for this example we will be using "EXE 06") - Accept.
7. Select - **Operation** - **O3 Generator** - Accept (the flow will default to the lowest flow possible, typically 0.50 slpm).
8. Edit - **Flow** - (set to the flow to the value required for the instruments connected with a little excess to the output manifold, for this example we will set it to 5.0 slpm.) - Accept.
9. Select - **Diluent** - (change to gas required for generating Ozone, typically **AIR**) - Accept.
10. Off - **Zero Point** - Off (this will allow the Ozone generator to produce Ozone)
11. Select - **Units** - (this will not have an impact on the home screen units, so we suggest selecting the units that are most relevant for the concentration set point the user is requesting. For this example, we will select "ppm") - Accept.
12. Edit - **Set Point** - (this is where the user can set the concentration required from the Ozone Generator. For this example, we will select "0.3500ppm") - Accept.

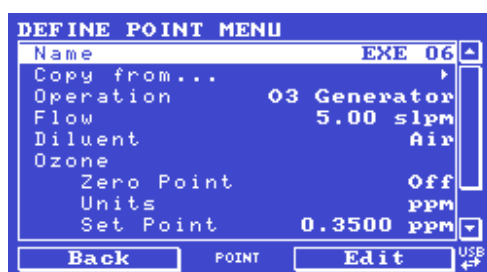

Figure 54 – O3 Generator Setup

13. Return to the **Home Screen** (the user can press the bottom status light (green)).
14. This Point is now configured correctly and can be started automatically (via serial commands or digital bits) or manually (via the **Quick Menu**).

15. Open - **Quick Menu**.

16. Select - **Mode** - Point - Accept - EXE 06 - Accept.

Note: Figure 55 shows the Home Screen with the Serinus Cal automatically controlling the dilution and Ozone flow to give the user their total flow requested in the point definition.



Figure 55 – Home Screen Running EXE 06 Point

Note: Some of the menu items in the **Define Point Menu** that were not discussed were the ‘Copy From...’, ‘Input Mask’ and ‘Output Mask’. The ‘Copy From...’ feature can be used make quick copies of existing points that are similar or that were developed in **Manual Point Menu**. The ‘Input Mask’ and ‘Output Mask’ relate to the two lots of eight digital bits that can be used to automatically start points (digital input) and give a digital output to give an indication or control other instruments or relays (digital output).

3.2.2.6 O3 Gen/Photometer (Serinus Cal 3000)

Step by Step Example:

1. Open - **Main Menu** → **Gas Supply Menu**
2. Select - **Diluent Port 1** - (change from **None** to the gas physically connected to the diluent port, typically **AIR**. When using the O3 Generator operation the user must select a diluent that contains sufficient oxygen so the Ozone generator can produce Ozone).
3. Return to the **Home Screen** (the user can press the bottom status light (green)).

Note: Now that the **Diluent** has been defined, the **Point** can be defined. There are some menu items that will not be used in the steps, an explanation is given at the end of the example. **Define Point Menu** has 64 available programmable points.

4. Open - **Main Menu** → **Points & Sequences Menu** → **Define Points Menu**.
5. Edit - **Point 7**.
6. Edit - **Name** - (give the point a name that will help distinguish it from the others, for this example we will be using “EXE 07”) - Accept.
7. Select - **Operation** - **O3 Gen/Photometer** - Accept (the flow will default to the lowest flow possible, typically 0.50 slpm).
8. Edit - **Flow** - (set to the flow to the value required for the instruments connected to the output manifold, for this example we will set it to 5.0 slpm) - Accept.
9. Select - **Diluent** - (change to gas required for generating Ozone, typically **AIR**) - Accept.
10. Off - **Zero Point** - Off (this will allow the Ozone generator to produce Ozone)

11. Select - **Units** - (this will have an impact on the home screen units, so we suggest selecting the units that are most relevant for the concentration set point the user is requesting. For this example, we will select “ppm”) - Accept.
12. Edit - **Set Point** - (this is where the user can set the concentration required from the Ozone Generator. For this example, we will select “0.3500ppm”) - Accept.

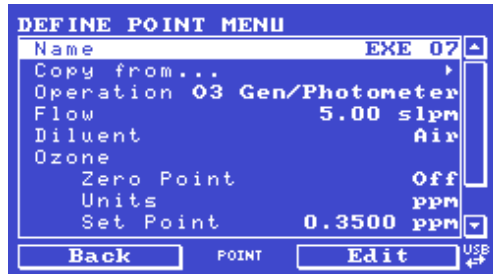

Figure 56 – O3 Gen/Photometer Setup

13. Return to the **Home Screen** (the user can press the bottom status light (green)).
14. This Point is now configured correctly and can be started automatically (via serial commands or digital bits) or manually (via the **Quick Menu**).
15. Open - **Quick Menu**.
16. Select - **Mode** - Point - Accept - EXE 07 - Accept.

Note: Figure 57 shows the Home Screen with the Serinus Cal automatically controlling the dilution and Ozone flow to give the user their total flow requested in the point definition.

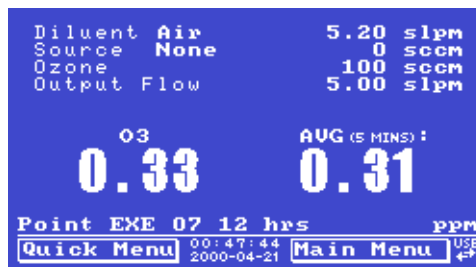

Figure 57 – Home Screen Running EXE 07 Point

Note: Some of the menu items in the **Define Point Menu** that were not discussed were the “Copy From...”, “Input Mask” and “Output Mask”. The “Copy From...” feature can be used make quick copies of existing points that are similar or that were developed in **Manual Point Menu**. The “Input Mask” and “Output Mask” relate to the two lots of eight digital bits that can be used to automatically start points (digital input) and give a digital output to give an indication or control other instruments or relays (digital output).

3.2.2.7 Sequence

Once the user has defined some points they can define a sequence. A sequence is a collection of defined points connected by steps. Each step has duration and uses the point definition. The end of the sequence is defined by either Idle, repeat or using up all 16 steps. The steps don’t always need to be points they can be linked to other sequences, allowing nested sequences. This method can only go three sequences deep before the user get a nesting error. The following example demonstrates a GPT setup using the points created in Section 3.2.2.4.

Step by Step Example:

1. Open - **Main Menu** → **Points & Sequencing Menu** → **Define Sequences Menu**.
2. Edit - **Sequence 1**.
3. Edit - **Name** - (give the point a name that will help distinguish it from the others, for this example we will be using "GPT 1") - Accept.
4. Edit - **Step 1** - (change from **Idle** to **Point**) - (select "EXE 04" this is the point we made in Section 3.2.2.4 titration with Ozone) - Accept.
5. Edit - **Time** - (For this example we will use 20 mins) - Accept.
6. Edit - **Step 2** - (change from **Idel** to **Point**) - (select "EXE 05" this is the point we made in Section 3.2.2.4 titration without Ozone) - Accept.
7. Edit - **Time** - (for this example we will use 15 mins) - Accept.

Note: the next step (step 3) will default to Idle. This will indicate the end of the sequence; no adjustment is required by the user.



Figure 58 – Titration Sequence Setup

8. Return to the **Home Screen** (the user can press the bottom status light (green)).
9. This Sequence is now configured correctly and can be started automatically (via serial commands or digital bits) or manually (via the **Quick Menu**).
10. Open - **Quick Menu**.
11. Select - **Mode - Sequence** - Accept - **GPT 1** - Accept.

Note: Figure 59 shows the Home Screen with all the gas components within the Gas Standard displaying their new diluted concentration values as well as the Ozone concentration from the Ozone generator all concentrations are in ppm units. At the top we can also see the Serinus Cal automatically controlling the dilution, source and Ozone flow to give the user their total flow requested in the point definition.

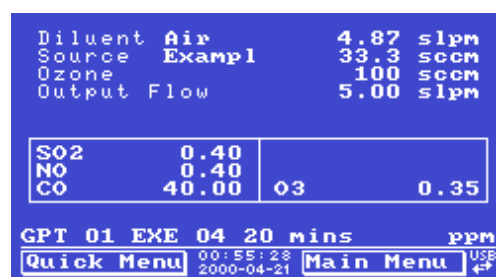

Figure 59 – Home Screen Running GPT 1 Sequence

Note: Some of the menu items in the **Define Point Menu** that were not discussed were the 'Copy From...', 'Input Mask' and 'Output Mask'. The 'Copy From...' feature can be used make quick copies of existing points that are similar or that were developed in **Manual Point Menu**. The 'Input Mask' and 'Output Mask' relate to the two lots of eight digital bits that can be used to automatically start points (digital input) and give a digital output to give an indication or control other instruments or relays (digital output).

12. Once a sequence is running the user can use the Mode feature in the quick menu to pause, skip, Rewind or Stop.

3.3 General Operation Information

3.3.1 Keypad & Display

The Serinus Cal is operated with the use of 4 sets of buttons:



Figure 60 – Front Panel

Selection Buttons (1)

The selection buttons will perform the function specified directly above it on the screen. Generally, this involves opening a menu, editing a value, accepting or cancelling an edit, or starting an operation.

Scrolling Buttons (2)

The scrolling buttons allow the users to scroll up and down through menus or selection boxes. The scrolling buttons are also used to scroll side to side through editable fields such as: dates, times, numbers etc.

On the main screen these buttons are used for adjusting the screen contrast. Press and hold the up button to increase contrast; press and hold the down button to decrease.

Keypad (3)

The keypad contains the numbers 0 - 9, a decimal point/minus key ($\bar{.}$) and a space/plus key (SPACE^+).

In the few cases where letters can be entered, the number keys act like a telephone keypad. Every time a number key is pressed, it cycles through its choices. The up/down arrow keys scroll through all the numbers and the entire alphabet.

Button	Function
1	1 or space, underline
2	2, A, B, C, a, b, c
3	3, D, E, F, d, e, f
4	4, G, H, I, g, h, i
5	5, J, K, L, j, k, l
6	6, M, N, O, m, n, o
7	7, P, Q, R, S, p, q, r, s
8	8, T, U, V, t, u, v
9	9, W, X, Y, Z, w, x, y, z
0	0 or space, underline
(⁺ _{SPACE}) and key (·)	<p>When editing a floating point number:</p> <p>The key (·) inserts a negative sign if the editing cursor is at the start of the number and negative signs are allowed. Otherwise it moves the decimal place to the current cursor location.</p> <p>inserts a positive sign if the cursor is at the start of the number; otherwise it enters a space.</p> <p>For non-floating point numbers:</p> <p>These keys usually increment or decrement the current value by 1. When editing the month field of a date, the (⁺_{SPACE}) and (·) key change the month.</p>

Instrument Status Light Buttons (4)

Located in the top left corner, these lights indicate the status of the instrument as a whole.

- A red light indicates that the instrument has a major failure and is not functioning.
- An orange light indicates there is a minor problem with the instrument, but the instrument may still run points reliably.
- A green light indicates that the calibrator is working and there are no problems.

In the case of an illuminated orange or red status light, go to the **Status Menu** to find which components are failing (refer to Section 3.5.17) or press the orange or red status light button to see a pop-up box with a full list of current faults.

Press the green status light button at any time to close any open edit box or menu and come back to the home screen.

If no instrument status lights are ON and the keypad is backlit, this indicates that the instrument is running the bootloader. The screen will also indicate that it is in bootloader menu.

3.4 Home Screen

The **Home Screen** is composed of six parts: Readings (1), Concentrations (2), Error (3), Status Line (4), Selection Buttons (5), Time and Date (6), USB Status (7), Concentration Units (8).

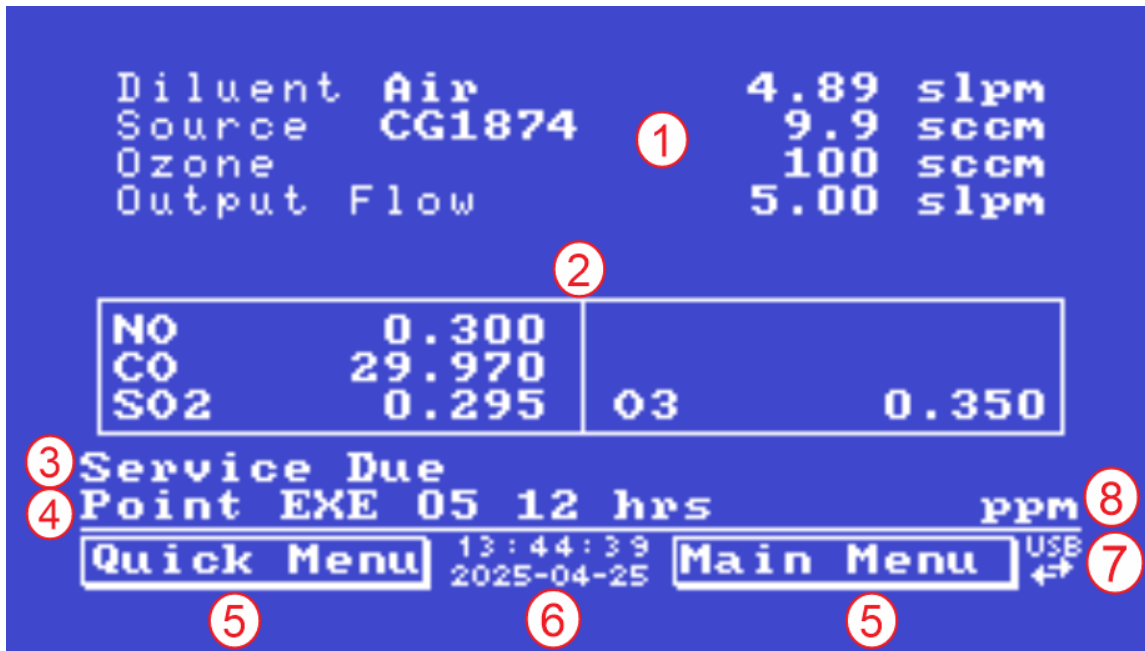

Figure 61 – Home Screen

Readings (1)

Displays the flow of each flow control device currently available in the system. The total flow distributed to the output port is also displayed.

Concentrations (2)

Displays concentration of each gas defined in the gas standard, which is currently being delivered to the output port.

Error (3)

The error line provides users with information on any problems the instrument may have. It displays the highest priority error condition contained in the Status menu.

Status Line (4)

The status line provides users with information on the current status of the instrument.

If a defined point or sequence is running, the name will appear on this line, along with the remaining time (in minutes) for the current point when running a sequence manual point.

Selection Buttons (5)

These buttons are used on the home screen to enter one of two menus. The **Quick Menu** (refer to Section 3.5.1) contains all information and features necessary for scheduled maintenance. The **Main Menu** (refer to Section 3.5.2) contains all information and fields available to the users and is generally only used during initial set-up and diagnostics.

The right button opens the **Main Menu** (refer to Section 3.5.2) contains all information and fields available to users and is generally only used during initial set-up and diagnostics.

Time and Date (6)

The time and date are displayed in between the menu buttons at the bottom of the screen.

USB Detection (7)

A USB symbol will be displayed in the bottom right corner when the USB memory stick is plugged in (the USB socket is behind the front panel). If the USB symbol is not shown the USB memory stick should be inserted. Underneath the USB symbol arrows may be displayed which indicates data transfer. The USB memory stick must not be removed whilst the arrows are visible.

Note: To safely remove the USB memory stick, navigate to the **Service Menu** and use the **Safely Remove USB Stick** function (refer to Section 3.5.27).

Concentration Units (8)

The instrument units are displayed in the bottom right corner of the display.

3.5 Menus & Screens

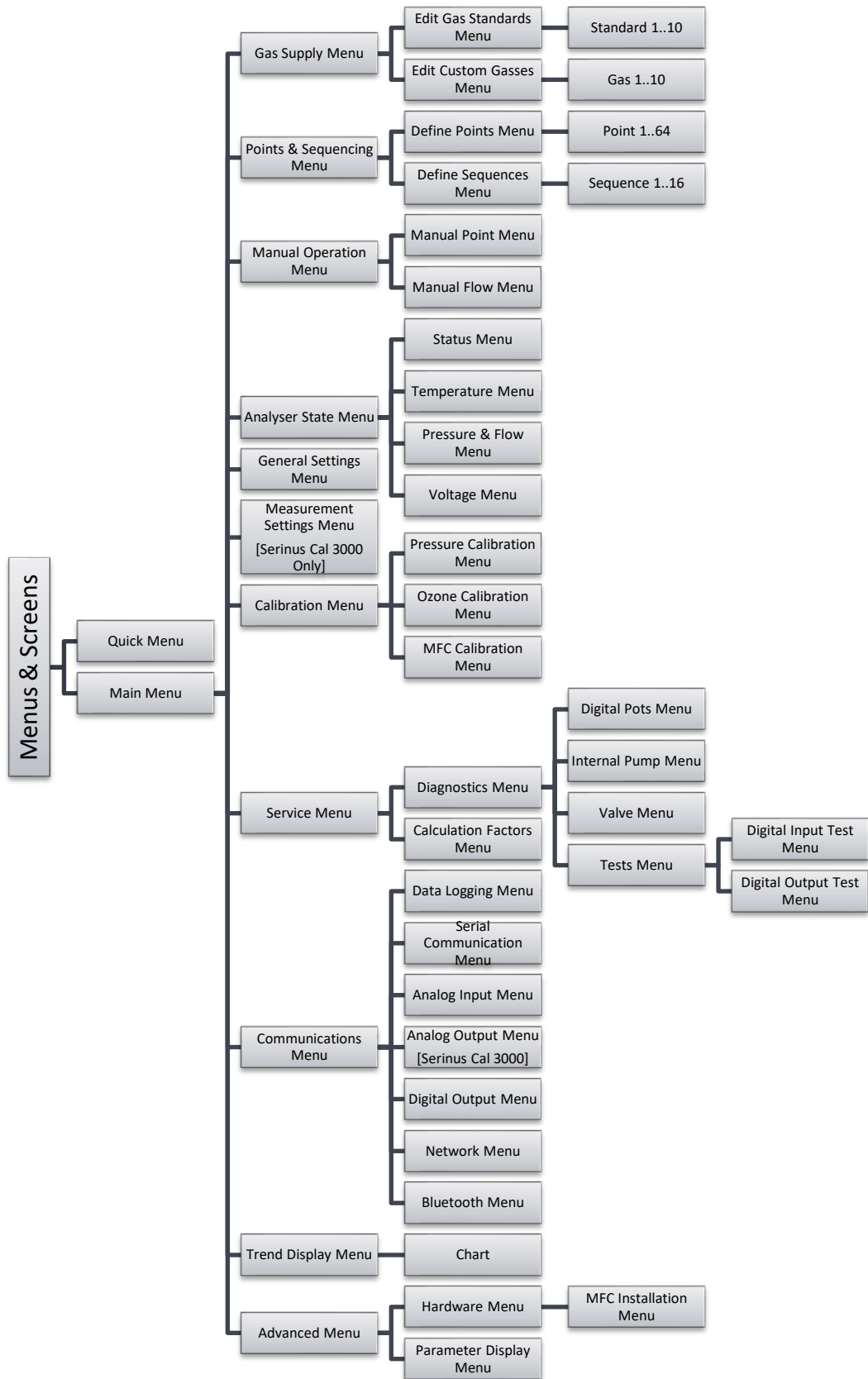

To begin using the Serinus Cal, a number of parameters must be programmed into the unit through the menu system. This section of the manual gives an overview of the menu system to the user. To access these items, press the Menu button while on the home screen.

In general, editable parameters are displayed in bold font. Non-editable information is displayed in a thin font. Some parameters may become editable based on the state of the instrument.

Sub-menus will be indicated with a small arrow; pressing the right-hand button on these items will open a new menu or a dialog box.

3.5.1 Quick Menu

The **Quick Menu** contains all the maintenance tools in one easy to use screen. It allows operators to perform calibrations, check important parameters and review the service history.

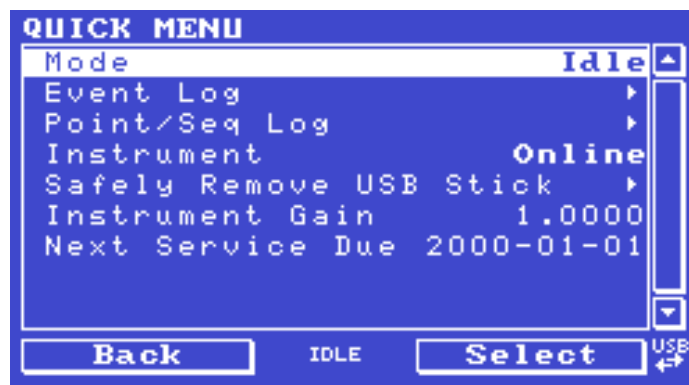

Figure 62 – Quick Menu Screen

Mode	Allows the user to select a mode of operation. Refer to Section 3.5.1.1
Event Log	This field enters a screen with a log of all the events that the instrument has performed. These events include errors and warnings. This log is stored on the removable USB memory stick. The log is organised by month. When the user enters this screen they will be prompted to enter the month for which they wish to view events.
Point/Seq Log	This field enters a screen with a log of all the actions the calibrator has performed. Every time a point or sequence starts and stops, is edited, when a sequence repeats, when the mode is changed (e.g. idle, manual...) and when the pause skip or rewind function is used. This log is stored on the removable USB memory stick. The log is organised by month. When the user enters this screen they will be prompted to enter the month for which they wish to view actions.
Instrument	This field allows the instrument to be set to either Online (normal instrument operation) or In Maintenance (data is flagged as invalid).
Safely Remove USB Stick	Always select this menu item before removing the USB memory stick or select the same menu item from the Service Menu (refer to Section 3.5.27). Failure to do this may cause corruption of the memory stick.
Instrument Gain [Serinus Cal 3000]	Shows the user the instrument gain of the photometer.

Next Service Due	A field that notifies the user when the next instrument service is due. This value is editable in the Next Service Due field of the Advanced Menu (refer to Section 3.5.46). This field is only displayed in the 2 weeks prior to the date displayed in this field or after the date has occurred.
-------------------------	--

3.5.1.1 Mode

Quick Menu → Mode

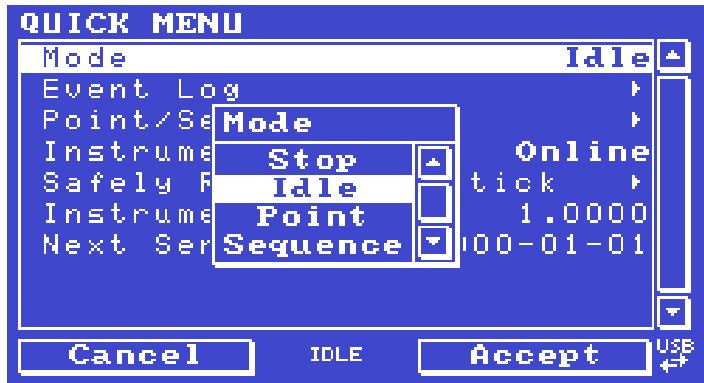

Figure 63 – Mode Screen

Stop	The instrument stops all flows, closes all valves, and does not respond to any other input (manual, serial or digital).
Idle	The default state. The instrument is not running any points or sequences but will respond to any request to do so. Selecting this option from the Mode button will terminate any point or sequence currently active.
Point	The instrument is currently running a point. Selecting this option from the Mode button will allow the user to initiate a new point.
Sequence	The instrument is currently running a sequence. Selecting this option from the Mode button will allow the user to initiate a new sequence.
Pause [Running a Sequence]	The instrument is attempting to run a sequence but the user has asked it to pause. This means the instrument remains in the current point indefinitely (until resumed) instead of moving on to the next point once the count-down has expired.
Resume [Running a Sequence]	When a sequence is paused, opening the Mode button will allow the choice to resume. This continues the point's countdown from where it was paused.
Skip [Running a Sequence]	While running a sequence the Mode button can be used to skip ahead to the next point.
Rewind [Running a Sequence]	While running a sequence the Mode button can be used to rewind back to the previous point.

3.5.2 Main Menu

There are various menus available on the **Main Menu** screen.



Figure 64 – Main Menu Screen

Gas Supply Menu	Refer to Section 3.5.3.
Points & Sequencing Menu	Refer to Section 3.5.8.
Manual Operation Menu	Refer to Section 3.5.11.
Analyser State Menu	Refer to Section 3.5.16.
General Settings Menu	Refer to Section 3.5.21.
Measurement Settings Menu [Serinus Cal 3000 Only]	Refer to Section 3.5.22.
Calibration Menu	Refer to Section 3.5.23.
Service Menu	Refer to Section 3.5.27.
Communications Menu	Refer to Section 3.5.36
Trend Display Menu	Refer to Section 3.5.44

3.5.3 Gas Supply Menu

Main Menu → Gas Supply Menu

In this menu, the user can define the names and concentrations of the different gases used throughout the system.



Figure 65 – Gas Supply Menu Screen

Diluent Port 1	This editable field displays the name of the gas connected to the diluent port 1.
Diluent Port 2 [Dual Diluent Valve Option]	This editable field displays the name of the gas connected to the diluent port 2.
Source Port 1..4	This editable field displays the name of the defined gas standard connected to the physical source port from 1 to 4 on the rear of the Serinus Cal. A standard setup only has 4 source ports. If the user has the dual source MFC option installed, source port 4 is no longer available.
Source Port 5..8 [Optional Source Option]	This editable field displays the name of the defined gas standard connected to the physical source port from 5 to 8 on the rear of the Serinus Cal. This is an installed option.
Edit Gas Standards Menu	This submenu allows the user to define the composition of the gas standard available (refer to Section 3.5.5).
Edit Custom Gasses Menu	This submenu allows the user to create a user defined gas composition (refer to Section 3.5.6).
Purge Mode	Select this mode to enable the automatic purge feature. Disabled: No purging occurs. Change Source: Whenever gas is drawn from a standard for the first time, purge the line. If the user run a series of points or sequences that only use one gas standard, no additional purging will occur. Start Source: Whenever gas is drawn from a standard, purge the line, unless running a sequence. The line will still be purged if the user run points or sequences that use different gas standards. This mode is useful for manual operation, as it is a good idea to purge if the instrument has sat idle for too long. However, if the user run a sequence that only uses a single gas standard, it will only be purged at the beginning of the sequence.
Purge Time [Purge Mode Enabled]	Set the purge time in seconds. If this value is set to 0, purging is disabled (just as if Purge Mode were set to Disabled).

3.5.4 Edit Gas Standards Menu

Main Menu → Gas Supply Menu → Edit Gas Standards Menu



Figure 66 – Edit Gas Standards Menu Screen

Edit Standard	This is a quick method for the user to access the gas standard they wish to edit.
Reset All Standards	This will erase all the current definitions stored in the USB memory stick.
Standard 1..10	Leads to the Edit Gas Standard Menu submenu where the user can edit a specific gas standard (refer to Section 3.5.5). The list of gas standards and their definitions are not stored in the instrument’s EEPROM like other configuration settings. Instead, they are stored on the USB memory stick in a file named “Standard.dat”.

3.5.5 Edit Gas Standard Menu

Main Menu → Gas Supply Menu → Edit Gas Standards Menu → Standard 1..10



Figure 67 – Edit Gas Standard Menu Screen

Name	Name of the gas standard.
Serial No.	Serial number of the gas standard. This field may contain letters and numbers, up to 15 characters long.
Expiration	Expiration date of the gas standard.
Balance Gas	Balance gas of the gas standard.
Component Gases	Up to 6 gases can be defined for each standard. The last gas will be defined as NONE. Simply select a gas name and a new blank entry will appear at the end of the list.

Gas 1..6	Gas name.
Units	Units for the gas concentration.
Conc.	Gas concentration.

3.5.6 Edit Custom Gasses Menu

Main Menu → Gas Supply Menu → Edit Custom Gasses Menu

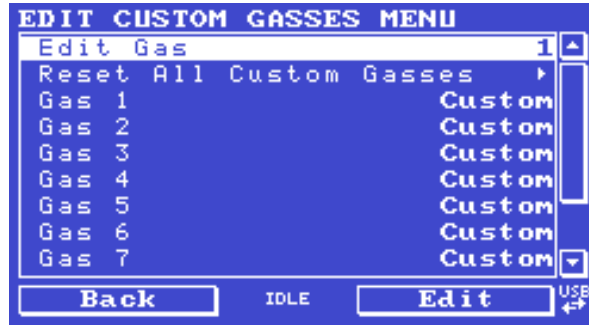

Figure 68 – Edit Custom Gasses Menu Screen

Edit Gas	This is a quick method for the user to access the custom gas they wish to edit.
Reset All Custom Gasses	This will erase all the current definitions stored in the USB memory stick.
Gas 1..10	Leads to the Edit Custom Gas Menu submenu where the user can edit a specific custom gas (refer to Section 3.5.7). The list of predefined gases and custom gasses and their definitions are not stored in the instrument's EEPROM like other configuration settings. Instead, they are stored on the USB memory stick in a file named "Gas.dat".

3.5.7 Edit Custom Gas Menu

Main Menu → Gas Supply Menu → Edit Custom Gasses Menu → Gas 1..10



Figure 69 – Edit Custom Gas Menu Screen

Name	Name of the custom gas (limited to 6 letters or numbers).
Copy from...	Copy the definition of a predefined gas or custom gas.

Structure	This is where the user can select the molecular structure of the custom gas. Monoatomic, Diatomic, Triatomic and Polyatomic.
Temperature	This is where the user enters the Specific temperature, CP of the custom gas. (cal/g °C)
Density	This is where the user enters the standard density of the custom gas. (g/l @ 0 °C)
Pure MFC	This is where the user enters the mass flow controller gas correction factor relative to nitrogen.
Molecular Weight	This is the weight g/mol of your custom gas.

3.5.8 Points & Sequencing Menu

Main Menu → Points & Sequencing Menu

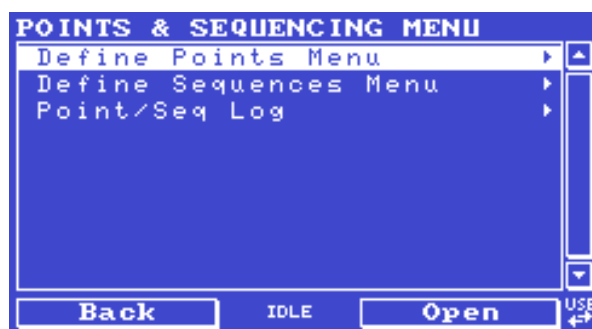

Figure 70 – Edit Custom Gasses Menu Screen

Define Points Menu	Refer to Section 3.5.9.
Define Sequences Menu	Refer to section 3.5.11.
Points/Seq Log	Records all the events relating to points and sequences.

3.5.9 Define Points Menu

Main Menu → Points & Sequencing Menu → Define Points Menu



Figure 71 – Define Points Menu Screen

Edit Point	This is a quick method for the user to access the point definition they wish to edit.
Reset All Points	This will erase all the current point definitions stored in the USB memory stick.
Point 1..64	Select a point to edit (from 1 - 64), this leads the user to the Define Point Menu submenu. Note that the point definitions are not stored in the instrument's EEPROM. Instead, they are stored on the USB flash drive in a file named "Point.dat".

3.5.10 Define Point Menu

Main Menu → Points & Sequencing Menu → Define Points Menu → Point 1..64

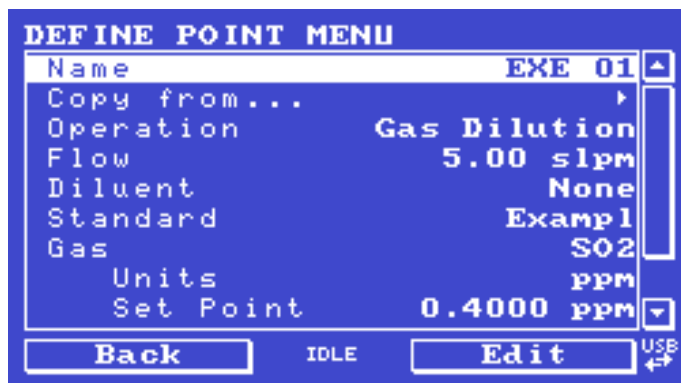

Figure 72 – Define Point Menu Screen

Name	Enter a name for the point (limited to 6 letters or numbers).
Copy from...	Copy the definition of another point into this one. Useful for making a series of points that only differ in one or two small ways.
Operation	The type of operation for this point. Refer to Section 3.5.10.1 to Section 3.5.10.6 for details of each operation.
[Various]	Various fields will be displayed based on the type of Operation selected.
Input Mask	When the digital input lines match this pattern, the point will automatically trigger. An X means the pattern will trigger regardless of the state of that line. If the pattern is set to all XXXXXXXX, it will never be triggered by the digital input lines. Conversely, if it is set to XXXXXX1, the point will automatically be triggered as soon as the instrument turns ON, as the default state of the digital input lines is 11111111. Remember that selecting manual operation, or manually starting a point or sequence, will temporarily disable the digital input controls.
Output Mask	The digital output lines will be a combination (OR operation) of this pattern, the sequence DIO output mask (if running a sequence) and the DIO Output Mask (refer to the Digital Output Menu , Section 3.5.41). An X will have no impact on the combination (i.e. any bits marked X here will either be set by the sequence or the DIO Output Mask).

3.5.10.1 Gas Dilution

The standard operation of the instrument: mixing source gas with diluent.

Flow	Desired flow delivered to the output port. If the Set Point the user selected is incompatible with this flow, they will be asked if they want to change the Set Point.
Diluent	The diluent to be used; selected from the diluents attached to the instrument if the user has the dual diluent option.
Standard	The gas standard to be used; selected from the list of gas standards attached to the instrument. Refer to Gas Standards Menu 0 .
Gas	Selected from the gasses available from the gas standard.
Units	Units for the desired concentration. These are the units that all the gasses will be displayed in on the Home Screen .
Set Point	The desired concentration. If the Flow the user selected is incompatible with this concentration, they will be asked to select a new Flow.

3.5.10.2 Zero Point

Provide a specified amount of diluent flow, without source gas.

Flow	Desired flow delivered to the output port.
Diluent	The diluent to be used; selected from the diluents attached to the instrument if the user has the dual diluent option.

3.5.10.3 Source Control

Provide a specified amount of source flow.

Flow	Desired flow delivered to the output port.
Standard	The Gas standard to be used; selected from the list of gas standards attached to the instrument. Refer to Gas Standards Menu 0 .
Gas	Selected from the gasses available from the gas standard.
Units	Units for the desired concentration. These are the units that all the gasses will be displayed in on the Home Screen .
Set Point	Since there is no diluent, the concentration set point for the gas must be the same as the concentration in the source.

3.5.10.4 Titration [Serinus Cal 2000 and 3000]

Mix a diluted gas source with generated Ozone.

Flow	Desired flow delivered to the output port. If the Set Point the user selected is incompatible with this flow, they will be asked if they want to change the Set Point.
Diluent	The diluent to be used; selected from the diluents attached to the instrument if the user has the dual diluent option.

Standard	The gas standard to be used; selected from the list of gas standards attached to the instrument. Refer to Gas Standards Menu 0 .
Gas	Selected from the gasses available from the gas standard.
Units	Units for the desired concentration. These are the units that all the gasses will be displayed in on the Home Screen .
Set Point	The desired concentration. If the Flow the user selected is incompatible with this concentration, they will be asked to select a new Flow.
Ozone	<p>The amount of Ozone to produce.</p> <p>Photometer Corrected Titration: During a titration the Ozone cannot be measured by the photometer. Thus the Ozone level is set by a calibrated lamp control point, which may not be as accurate. However, if an O3Gen/Photometer point is run long enough to achieve a stable result, the point's flow and Ozone concentration are recorded. If a titration point with the same flow and concentration is then requested within five minutes after the O3Gen/Photometer stops running, the Ozone lamp will be set to the stabilized value rather than the calibrated value.</p> <p>This is indicated by appending (C) to the Ozone label on the main screen. It is also indicated by Advanced Parameter 253, which is set to 1 once a O3Gen/Photometer point has reached stability (or 0 if the stabilized value has expired and is no longer reliable).</p>
Zero Point	When this option is ON, the set point is fixed to 0.0 and the Ozone lamp is turned OFF. This is necessary when running the NO point.
Units	Units for entering the desired concentration of Ozone. On the home screen, the Ozone will be displayed in the source units.
Set Point	The desired concentration of Ozone. Note that the amount of Ozone that can be delivered depends on the flow.

3.5.10.5 O3 Generator [Serinus Cal 2000 and 3000]

Generate and dilute Ozone.

Flow	<p>Desired flow delivered to the output port.</p> <p>If the Set Point the user selected is incompatible with this flow, they will be prompted if they want to change the Set Point.</p>
Diluent	The diluent to be used; selected from the diluents attached to the instrument if the user has the dual diluent option.
Ozone	The amount of Ozone to produce.
Zero Point	When this option is ON, the set point is fixed to 0.0 and the Ozone lamp is turned OFF. This is necessary when calibrating the photometer.
Units	Units for the desired concentration. These are the units that all the gasses will be displayed in on the Home Screen .
Set Point	The desired concentration of Ozone. Note that the amount of Ozone that can be delivered depends on the flow.

3.5.10.6 O3 Gen/Photometer [Serinus Cal 3000]

Generate and dilute Ozone under photometer control. The amount of Ozone delivered will be constantly monitored and adjusted by a feedback loop, to remain at the desired concentration.

Flow	Desired flow delivered to the output port. If the Set Point the user selected is incompatible with this flow, they will be asked if they want to change the Set Point.
Diluent	The diluent to be used; selected from the diluents attached to the instrument if the user has the dual diluent option.
Ozone	The amount of Ozone to produce.
Zero Point	When this option is ON, the set point is fixed to 0.0 and the Ozone lamp is turned OFF. This is necessary when calibrating the photometer.
Units	Units for the desired concentration. These are the units that all the gasses will be displayed in on the Home Screen .
Set Point	The desired concentration of Ozone. Note that the amount of Ozone that can be delivered depends on the flow.

3.5.11 Define Sequences Menu

Main Menu → Points & Sequencing Menu → Define Sequences Menu



Figure 73 – Define Sequences Menu Screen

Edit Sequence	This is a quick method for the user to access the sequence definition they wish to edit.
Reset all sequences	This will erase all the current sequence definitions stored in the USB memory stick.
Sequence 1..16	Select a sequence to edit (from 1 - 16). Note that the sequence definitions are not stored in the instrument's EEPROM. Instead, they are stored on the USB flash drive in a file named "Sequence.dat".

3.5.12 Define Sequence Menu

Main Menu → Points & Sequencing Menu → Define Sequences Menu → Sequence 1..16



Figure 74 – Define Sequence Menu Screen

Name	Enter a name for the sequence (limited to 6 letters or numbers).
Copy from...	Copy the definition of another sequence into this one.
Timed Start	When Timed Start is turned On it allows the user to define a time and date for the sequence to start running. The only other condition is that the instrument must be in "Idle" mode, while in any other mode the Timed Start will be ignored.
Date [Timed Start On]	Displays the date that the sequence is due to run.
Time [Timed Start On]	Edit and display the time that the sequence will run. The time is set using a 24 hour clock.
Repeat [Timed Start On]	Defines an interval value for the repeat of the sequence based on the Units selected. This field indicates the delay period; once the specified amount of time has lapsed the sequence will automatically run again. The user can edit this field but some restriction apply depending on the Units selected. Default is "1".
Units [Timed Start On]	This is where the user can define the type of units for the Repeat delay period. For example: A Repeat of "1" and Units of "Days" means that the sequence will automatically run every day at the defined time. Default is "Days"
Step 1-16	Define the task to perform at this point in the sequence. Idle : The sequence is terminated and the instrument goes to the IDLE state. Point : Load a point for a specified amount of time. Sequence : Load a sequence and repeat it a specified number of times. Note that the user may only nest sequences three deep; that is, Seq A can call Seq B, which can call Seq C. If the user attempt to have Seq C call another sequence, the entire sequence will terminate with an error. The user

	<p>may call sequences in order as many times as they like: so Seq A can call Seq B, C, D, and E one after the other.</p> <p>Repeat: Go back to the beginning of the sequence and start over.</p>
Time [Point]	Run the named point for this many minutes. At the end of that time the sequence advances to the next task.
Repeats [Sequence]	Repeat the named sequence this many times. At the end of that loop the sequence advances to the next step.
Input Mask	<p>When the digital input lines match this pattern, the sequence will automatically trigger. An X means the pattern will trigger regardless of the state of that line. If the pattern is set to all XXXXXXXX, it will never be triggered by the digital input lines. Conversely, if it is set to XXXXXXX1, the sequence will automatically be triggered as soon as the instrument turns ON, as the default state of the digital input lines is 11111111.</p> <p>Remember that selecting manual operation, or manually starting a point or sequence, will temporarily disable the digital input controls.</p>
Output Mask	<p>The digital output lines will be a combination (OR operation) of this pattern, the point DIO output mask (if running a sequence) and the DIO Output Mask (refer to Digital Output Menu, Section 3.5.41). An X will have no impact on the combination (i.e. any bits marked X here will either be set by the point or the DIO Output Mask).</p>

3.5.13 Manual Operation Menu

Main Menu → Manual Operation Menu



Figure 75 – Manual Operation Menu Screen

Manual Timeout	<p>When using the manual point menu to operate the instrument, the instrument will automatically return to the “Idle” state after this timeout has expired.</p> <p>If the Manual Timeout is set to 0, then no timeout is used. The instrument will remain in the manually selected state indefinitely.</p>
Manual Point Menu	Refer to Section 3.5.14.

Manual Flow Menu	Refer to Section 3.5.15.
------------------	--------------------------

3.5.14 Manual Point Menu

Main Menu → Manual Operation Menu → Manual Point Menu

This menu allows the user to operate the instrument directly (without defining a point). This may be used when experimenting with points it can then later be copied into a permanent point definition with the “Copy from...” feature.



Figure 76 – Manual Point Menu Screen

Mode	This is the same as the Mode in the Quick Menu.
Operation	The type of operation. Refer to Sections 3.5.10.1, 3.5.10.2, 3.5.10.3, 3.5.10.4 and 3.5.10.5 for operation descriptions.
[Various]	Various fields will be displayed based on the type of operation selected.
Output Mask	The digital output lines will be a combination (OR operation) of this pattern, the sequence DIO output mask (if running a sequence) and the DIO Output Mask (refer to the Digital Output Menu , Section 3.5.41). An X will have no impact on the combination (i.e. any bits marked X here will either be set by the sequence or the DIO Output Mask).
Audit Mode	Provides a method for external audits of the photometer. When turned ON, a warning dialog box appears, stating “Connect external Ozone generator”. The point is then forced into a Zero point (if it isn't already) and operation is set to O3 Gen/Photometer . While running this point, the MFCs are locked closed and their flow alarms are suppressed. The new status condition "Audit Mode" will be triggered, forcing a yellow warning light. Otherwise, the point runs as normal.
Purge	Manually initiate a purge of the source.

3.5.15 Manual Flow Menu

Main Menu → Manual Operation Menu → Manual Flow Menu

For calibration and test it is often necessary to directly control the MFC flows.

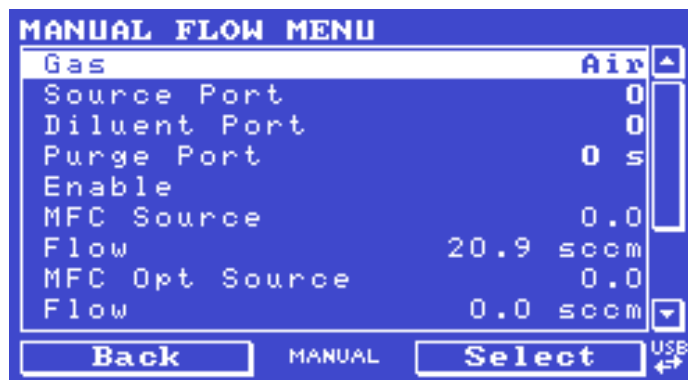

Figure 77 – Manual Flow Menu Screen

Gas	Indicate which gas is being provided. This is used to calculate the MFC correction factor.
Source Port	Select a source port to open. 0 indicates no port.
Diluent Port	Select a diluent port to open. 0 indicates no port.
Purge Port	Open the purge port for the specified amount of seconds. This value will count down and when it reaches 0 the purge port will be closed.
Enable	This enable the MFC source or MFC Opt Source.
MFC Source	Enter the desired flow for the source MFC (in sccm).
Flow	Displays the measured flow for the above MFC.
MFC Opt Source	Enter the desired flow for the optional 2nd source MFC (in sccm).
Flow	Displays the measured flow for the above MFC.
MFC Diluent	Enter the desired flow for the diluent MFC (in sccm).
Flow	Displays the measured flow for the above MFC.
MFC Opt Diluent	Enter the desired flow for the optional 2nd diluent MFC (in sccm).
Flow	Displays the measured flow for the above MFC.

3.5.16 Analyser State Menu

Main Menu → Analyser State Menu

This displays the status of various parameters that affect instrument measurements.



Figure 78 – Analyser State Menu Screen

Status Menu	Refer to Section 3.5.17.
Temperature Menu	Refer to Section 3.5.18.
Pressure & Flow Menu	Refer to Section 3.5.19.
Voltage Menu	Refer to Section 3.5.20.
Model	This field will always display Serinus plus the model 300, 1000, 2000 or 3000.
Nominal Range [Serinus Cal 3000]	This is the nominal range of the photometer.
Ecotech ID	The Acoem ID number (called Ecotech ID in firmware).
Serial No.	The main controller PCA serial number.
Board Revision	The main controller PCA version.
Firmware Ver.	This field displays the firmware version currently in use on this instrument. This can be important when performing diagnostics and reporting back to the manufacturer.
Power Failure	This field displays the time and date of the last power failure or when power was disconnected from the instrument.

3.5.17 Status Menu

Main Menu → Analyser State Menu → Status Menu

The Status Menu presents a list of the current Pass/Fail statuses of the main components. During warm-up, the status of some parameters will be a dashed line.



Figure 79 – Status Menu Screen

Event Log	This field enters a screen with a log of all the events that the instrument has performed. These events include errors and warnings. This log is stored on the USB memory stick. The log is organised by month. When the user enters this screen they will be prompted to enter the month for which they wish to view events.
Show Error List	This field allows the user to display the list of current errors and warnings on the screen.

Next Service Due	This field is visible with the next service due date if the service is due within the next two weeks.
Maintenance Mode	Ok if the instrument is online and Error if the instrument is in maintenance mode. Refer to Service Menu (refer to Section 3.5.27) or Quick Menu (refer to Section 3.5.1).
+5V supply	Pass if the +5 V power supply to the main board is within the acceptable range.
+12V supply	Pass if the +12 V power supply is within the acceptable range.
+Analog Supply	Pass if the analogue power supply is within the acceptable range (+12 V).
-Analog Supply	Pass if the analogue power supply is within the acceptable range (-12 V).
A2D	Fail only if a problem is detected with the analog to digital conversion.
Ozone Lamp Temp. [Serinus Cal 2000 & 3000]	Pass if the Ozone generator lamp is the correct temperature.
Lamp Temp. [Serinus Cal 3000]	Pass if the photometer lamp is the correct temperature.
Lamp/Source [Serinus Cal 3000]	Checks if the photometer lamp current is within acceptable limits 8 - 12 mA.
Ref Voltage [Serinus Cal 3000]	Checks that the reference voltage is within acceptable limits 1.5 to 4.5 V.
System Power	Pass if the system has an adequate electrical supply.
Diagnostic Mode [Serinus Cal 3000]	Error if the electronics are in diagnostic mode. Refer to Digital Pots Menu (refer to Section 3.5.29).
Diagnostic PTF Comp [Serinus Cal 3000]	Error if the pressure /temperature compensation is disabled. Refer to Diagnostics Menu (refer to Section 3.5.28).
Diagnostic Control [Serinus Cal 3000]	Error if the control loop is disabled. Refer to Diagnostics Menu (refer to Section 3.5.28).
Valve Manual Control	Error if the valves have been placed in manual control mode. Refer to Valve Menu (refer to Section 3.5.31).
O3 Gen. Manual Control [Serinus Cal 2000 & 3000]	Error if the Ozone generator is under manual control. Refer to Digital Pots Menu (refer to Section 3.5.29).
O3 Conc. V Saturated [Serinus Cal 3000]	Indicates if the voltage of the concentration during photometer measurement is within the limits of the analog to digital converter (-0.26 to 3.29 V).
Bkgnd Conc. V Saturated [Serinus Cal 3000]	Indicates if the voltage of the concentration during photometer background measurement is within the limits of the analog to digital converter (-0.26 to 3.29 V).
Ozone Gen. Cal [Serinus Cal 2000 & 3000]	Fail if the instrument is performing an O ₃ generator calibration. Refer to Ozone Calibration Menu (refer to Section 3.5.25).
Pressure Calibration	Error if the user is performing a pressure calibration.

Flow Calibration [Serinus Cal 3000]	Error if the user is performing a flow calibration.
Photometer Flow Fault [Serinus Cal 3000]	Ok when the photometer has sufficient flow.
Full Stop	Error if the instrument is in STOP mode.
Manual Flow	Error if the instrument is under manual flow control (Refer to Manual Flow Menu Section 3.5.15).
Diluent Flow Fault	Ok when the diluent flow is within 5 % of specified flow.
Source Flow Fault	Ok when the source flow is within 5 % of specified flow.
Ozone Flow Fault [Serinus Cal 2000 & 3000]	Ok when the Ozone flow is within 10 % of 100 sccm.
Flow Block Temp. [Serinus Cal 3000]	Pass if the flow block temperature is within 10 % of the heater set point (to keep a constant accurate flow).
Chassis Temp.	Pass if the chassis temperature is within the acceptable limits (0 - 50 °C).
USB Stick Disconnect	This diagnostic status identifies whether a USB memory stick is properly inserted into the front USB port or if the analyser is unable to read the connected media.
Instrument Warmup [Serinus Cal 3000]	Ok once the photometer is out of warm-up status.
O3 Gen. Flow Fault [Serinus Cal 2000 & 3000]	Fail if the O3 Gen. Warm feature was enabled but there is insufficient flow through the Ozone generating chamber.
Audit Mode [Serinus Cal 3000]	Error if a manual O3 Gen/Photometer point is in audit mode.

3.5.18 Temperature Menu

Main Menu → Analyser State Menu → Temperature Menu

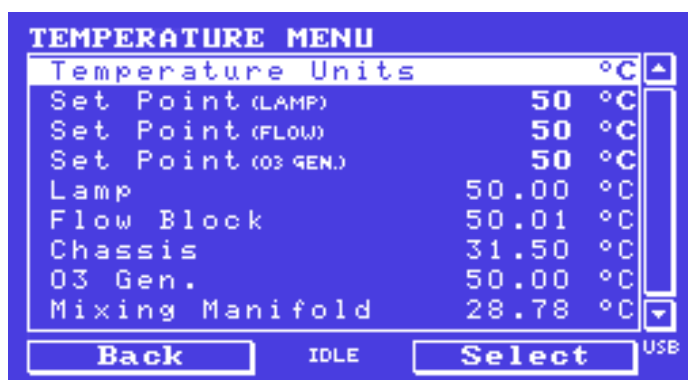

Figure 80 – Temperature Menu Screen

Temperature Units	The current temperature units of the instrument (Celsius, Fahrenheit, or Kelvin).
Set Point (LAMP) [Serinus Cal 3000]	The temperature set point of the photometer UV lamp. The factory default is 50 °C.
Set Point (FLOW) [Serinus Cal 3000]	The temperature set point of the flow block heater. The factory default is 50 °C.
Set Point (O3 GEN.) [Serinus Cal 2000 & 3000]	The temperature set point of the Ozone generating lamp. The factory default is 50 °C.
Lamp [Serinus Cal 3000]	The current temperature of the photometer lamp.
Flow Block [Serinus Cal 3000]	The current temperature of the flow block.
Chassis	The current temperature of air inside the chassis, measured on the main controller PCA.
O3 Gen. [Serinus Cal 2000 & 3000]	The current temperature of the Ozone generator.
Mixing Manifold [Serinus Cal 2000 & 3000]	The current temperature of the Ozone flow block.
Chassis Humidity	The current humidity inside the instrument, in percentage. This option is available only on Rev P or later boards.

3.5.19 Pressure & Flow Menu

Main Menu → Analyser State Menu → Pressure & Flow Menu

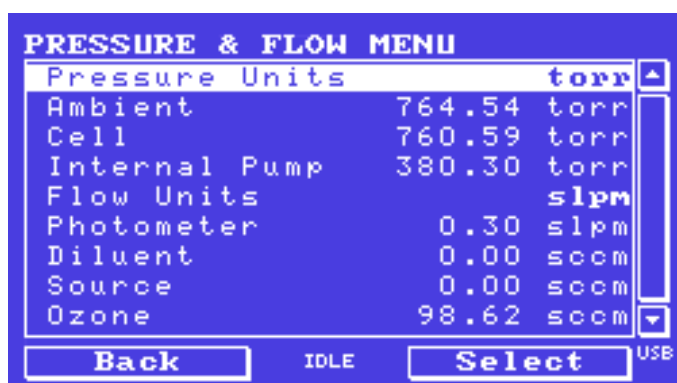

Figure 81 – Pressure & Flow Menu Screen

Pressure Units	Select the units that the pressure will be displayed in (torr, PSI, mBar, ATM, kPa).
Ambient	Current ambient pressure.
Cell [Serinus Cal 3000]	Current photometer cell pressure.
Internal Pump [Serinus Cal 3000]	Current photometer pumps pressure.

Flow Units	Select the units that the flow will be displayed in (slpm or L/min).
Photometer [Serinus Cal 3000]	The current photometer flow.
Diluent	The gas flow through the diluent MFC.
Source	The gas flow through the source MFC.
Ozone [Serinus Cal 2000 & 3000]	The current Ozone flow.

3.5.20 Voltage Menu

Main Menu → Analyser State Menu → Voltage Menu



Figure 82 – Voltage Menu Screen

Lamp Current [Serinus Cal 3000]	The photometer UV lamp current.
Conc. Voltage (RAW) [Serinus Cal 3000]	Voltage from the sensor proportional to the detected signal from the cell. This voltage represents the actual measurement of gas.
Conc. Voltage [Serinus Cal 3000]	Displays the detector voltage after PGA scaling.
Ref. Voltage [Serinus Cal 3000]	A voltage offset from the detector that is removed to measure the concentration voltage. This is set to 3 V (using the input pot) at start-up, and automatically adjusts if the reference voltage drops below 2 V or above 4 V.
O3 Gen. Current [Serinus Cal 2000 & 3000]	Ozone generator current.
+5V Supply	+5 V power supply.
+12V Supply	+12 V power supply.
+Analog Supply	+12 V (primary) power supply. The value should be within ± 2 V.
-Analog Supply	-12 V (primary) power supply. The value should be within ± 2 V.

3.5.21 General Settings Menu

Main Menu → General Settings Menu



Figure 83 – General Settings Menu Screen

Decimal Places	Select the number of decimal places (0 - 5) used for the concentration displayed on the home screen.
Reference Temperature	The flow measured by the MFC is corrected using the standard temperature for your region: 0, 20, or 25°C.
Temperature Units	Select the units that temperature will be displayed in °C (Celsius), °F (Fahrenheit), or K (Kelvin) .
Pressure Units	Select the units that the pressure will be displayed in (torr, PSI, mBar, ATM and kPa).
Flow Units	Select the units that the sample flow will be displayed in (slpm or L/min).
Date	The current instrument date.
Time	The current instrument time.
Backlight	Select the length of time the screen and keypad backlight remain ON after a button press. The setting Always Off means the backlight never turns ON; the setting Always On means the backlight never turns OFF.
Home Screen [Serinus Cal 3000]	This field allows the user to display concentrations on the Home Screen in three formats. Inst. only which displays only the instantaneous concentration reading. Inst & Avg which displays both instantaneous and average concentration on the Home Screen . Avg. Only which only displays the average concentration reading. The average is measured over the time period set in Measurement Settings Menu (refer to Section 3.5.22).
Char 0 has Slash	When enabled, the instrument will display the zero character with a slash (0) to differentiate it from a capital "O".

3.5.22 Measurement Settings Menu

Main Menu → Measurement Settings Menu

Note this menu only appears on a Serinus Cal 3000.



Figure 84 – Measurement Settings Menu Screen

Average Period [Serinus Cal 3000]	Allows the user to set the averaging period from 1 min to 24 hours
Min. Data Capture [Serinus Cal 3000]	Controls how much of the previous time period needs to be included before the average yields a number. The default is 0 %, which reflects past behaviour of the instrument: turning on a machine with 15-minute averaging and a setting of 0 % at 1:01 or 1:14 would produce ##### until 1:15 (because at 1:15, there was at least 1 valid measurement to construct the average from). Setting 100 % would mean the value stayed ##### until 1:30 (because there needs to be a complete 15 minutes worth of measurements to construct the average from).

3.5.23 Calibration Menu

Main Menu → Calibration Menu



Figure 85 – Calibration Menu Screen

Photometer [Serinus Cal 3000]	Displays the current photometer reading.
Average [Serinus Cal 3000]	Displays the average photometer reading based on the average set up in the measurement settings menu (refer to Section 3.5.22).
Audit Mode [Serinus Cal 3000]	Sets the instrument to sample from an external Ozone source. Used for calibration of the photometer. Refer to Section 5.7.
Span Calibrate O3 [Serinus Cal 3000]	Calibrate the photometer span point to the current reading. Note the instrument must be running a photometer point before it will enable this function.
Zero Calibrate O3 [Serinus Cal 3000]	Calibrate the zero point to the current reading. Note the instrument must be running a zero point before it will enable this function.
Pressure Calibration Menu	Refer to section 3.5.24.
Ozone Calibration Menu [Serinus Cal 2000 & 3000]	Refer to Section 3.5.25.
MFC Calibration Menu	Refer to Section 3.5.26.
Pressure O3 [Serinus Cal 3000]	The instrument cell pressure in the photometer during the last calibration.
Temperature [Serinus Cal 3000]	The instrument temperature during the last calibration.

3.5.24 Pressure Calibration Menu

Main Menu → Calibration Menu → Pressure Calibration Menu

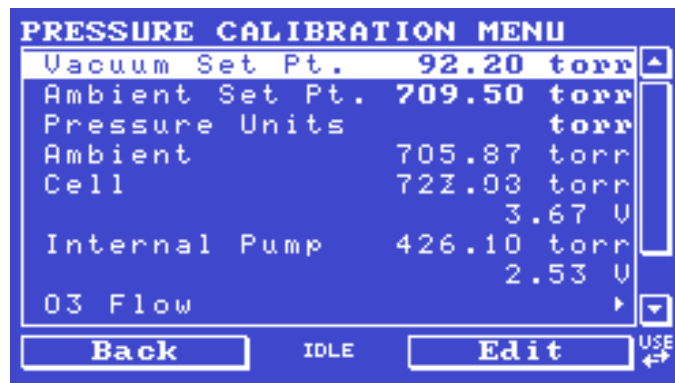

Figure 86 – Pressure Calibration Menu Screen

Vacuum Set Pt. [Serinus Cal 3000]	The zero point for the calibration. Activating this item will open a dialog box of instructions. Refer to Section 5.3 for the calibration procedure.
Ambient Set Pt.	The high point for the calibration. Activating this item will open a dialog box of instructions. Refer to Section 5.3 for the calibration procedure.
Pressure Units	Select the units that the pressure will be displayed in (torr, PSI, mBar, ATM or kPa).
Ambient	The current ambient pressure (displayed in pressure units and as a raw voltage).

Cell [Serinus Cal 3000]	The current photometer reaction cell pressure (displayed in pressure units and as a raw voltage).
Internal Pump [Serinus Cal 3000]	The current internal pump pressure (displayed in pressure units and as a raw voltage).
O3 Flow [Serinus Cal 2000 & 3000]	Calibrates the Ozone flow. Refer to Section 5.2 for the calibration procedure.
Vacuum Cal Mode [Serinus Cal 3000]	Defaults to OFF. When turned ON, the valves will be set to the same state as during a Vacuum Set Pt. adjustment, but there is no adjustment. Used for checking the accuracy of the vacuum pressure calibration. There are no dialog boxes or prompts, so the user needs to follow similar steps and precautions as during Vacuum Set Pt.
Ambient Cal Mode	Defaults to OFF. Similar to Vacuum Cal Mode, except the valves are set to check the ambient cal.

3.5.25 Ozone Calibration Menu

Note this menu only appears on a Serinus Cal 2000 & 3000.

Main Menu → Calibration Menu → Ozone Calibration Menu



Figure 87 – Ozone Calibration Menu Screen

Diluent [Serinus Cal 2000 & 3000]	Allows the user to select a diluent gas for the Ozone calibration.
Flow [Serinus Cal 2000 & 3000]	Specify the flow desired for the Ozone calibration process.
Min Range [Serinus Cal 2000 & 3000]	This is the minimum value for the Ozone generator calibration. The calibration is performed between the Min and Max values.
Max Range [Serinus Cal 2000 & 3000]	This is the maximum value for the Ozone generator calibration. The calibration is performed between the Min and Max values.
Ozone Calibration [Serinus Cal 2000 & 3000]	Refer to Section 5.4 and Section 5.5 for the calibration procedures.
Reset Ozone Cal [Serinus Cal 2000 & 3000]	Resets the Ozone calibration to factory default.

3.5.26 MFC Calibration Menu

Main Menu → Calibration Menu → MFC Calibration Menu

This menu allows a manual calibration of each MFC.

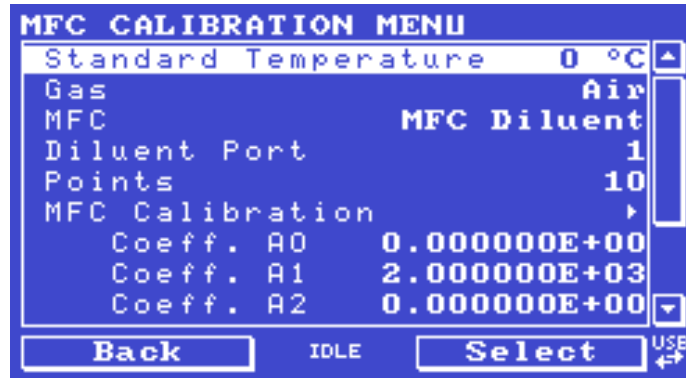

Figure 88 – MFC Calibration Menu Screen

Standard Temperature	User selected temperature for the MFC calibration.
Gas	Indicate which gas is being provided. This is used to calculate the MFC correction factor.
MFC	Select the MFC being calibrated.
Diluent Port [MFC – MFC Diluent]	Select a diluent port to open.
Source Port [MFC – MFC Source]	Select a source port to open.
Points	Select the number of points to include in the calibration (5 - 10).
MFC Calibration	Refer to Section 5.1 for the calibration procedures.
Coeff. A0	The polynomial terms for the MFC calibration. Default is 0.
Coeff. A1	The polynomial terms for the MFC calibration. Default is the maximum flow of the MFC in sccm divided by 5.
Coeff. A2	The polynomial terms for the calibration. Default is 0.
Readout Calibration	Refer to Section 5.1.3 for the calibration procedures.
Coeff. A0	The polynomial terms for the readout calibration. Default is 0.
Coeff. A1	The polynomial terms for the readout calibration. Default is 1.
Coeff. A2	The polynomial terms for the readout calibration. Default is 0.

3.5.27 Service Menu

Main Menu → Service Menu



Figure 89 – Service Menu Screen

Diagnostics Menu	Refer to Section 3.5.28.
Calculation Factors Menu [Serinus Cal 3000]	Refer to Section 3.5.35.
Load Auto-Backup Config.	Loads the auto-backup configuration file. The configuration is automatically backed up every night at midnight.
Load Configuration	Loads a configuration file from the USB memory stick.
Save Configuration	Saves all of the EEPROM-stored user-selectable analyser configurations to the USB memory stick (calibration and communication settings, units, instrument gain, etc.). If there are problems with the instrument use this function to save settings to the removable USB memory stick and send this file (and the parameter list) to your supplier with your service enquiry.
Save Parameter List	Saves a text file of various parameters and calculation factors. If the user has problems with the instrument use this function to save settings to the removable USB memory stick and send this file (and the configuration) to your supplier with your service enquiry.
Instrument	This field allows the instrument to be set to either Online (normal instrument operation) or In Maintenance (data is flagged as invalid).
Next Service Due	Displays when the next scheduled service is due.
Safely Remove USB Stick	This command must be activated to safely remove the USB memory stick.
System Restart	Activating this will restart the calibrator.

3.5.28 Diagnostics Menu

Main Menu → Service Menu → Diagnostics Menu



Figure 90 – Diagnostics Menu Screen

Digital Pots Menu	Refer to Section 3.5.29.
Internal Pump Menu [Serinus Cal 3000]	Refer to Section 3.5.30.
Valve Menu	Refer to Section 3.5.31.
Tests Menu	Refer to Section 3.5.32.
Pres/Temp/Flow Comp. [Serinus Cal 3000]	Set either ON or OFF. OFF is used when running diagnostics to see fluctuations in readings. The default state is ON, to compensate for environmental fluctuations.
Control Loop [Serinus Cal 3000]	When ENABLED is selected, the microprocessor maintains control of the digital pots; when DISABLED is selected, the microprocessor does not control the digital pots and the user can manually adjust the digital pots. The red traffic light will be ON while the control loop is disabled.

3.5.29 Digital Pots Menu

Main Menu → Service Menu → Diagnostics Menu → Digital Pots Menu

Digital pots are electronically controlled digital potentiometers used for adjustments to operations of the instrument. This menu should be accessed only during diagnostics.

Unless the **Control Loop** is **Disabled** (refer to **Diagnostics Menu**, Section 3.5.28), changes to the pots may be modified by the instrument. This is intentional; some diagnostics are best done with instrument feedback and some are best done without.



Figure 91 – Digital Pots Menu Screen

Lamp Adjust Pot [Serinus Cal 3000]	255	Sets the UV lamp current.
Lamp Current [Serinus Cal 3000]	9.5-10.5	Displays the UV lamp current in mA.
PGA Gain [Serinus Cal 3000]	1-128	Displays the gain of the PGA.
Input Pot [Serinus Cal 3000]	50-200	Reduces the raw signal to measurable level.
Conc. Voltage (RAW) [Serinus Cal 3000]	0-3.1	The concentration voltage measured by the analog to digital converter.
Conc. Voltage [Serinus Cal 3000]	0-3.1	The concentration voltage after adjustment for the PGA gain factor.
Meas. Zero Pot (COARSE) [Serinus Cal 3000]	50-200	Electronic zero for the measure channel.
Meas. Zero Pot (FINE) [Serinus Cal 3000]	0-255	Electronic zero for the measure channel.
Ref. Voltage [Serinus Cal 3000]	1.5-4	The reference voltage of the detector.
O3 Gen. Override [Serinus Cal 2000 and 3000]	On-Off	When On, enables the user to manually control of the O ₃ generator.
O3 Gen. Enable [Serinus Cal 2000 and 3000]	On-Off	When On allows the user to turn ON or OFF the O ₃ generator. Only editable if the Override is On .

O3 Gen. DAC [Serinus Cal 2000 and 3000]	0-65535	O ₃ generator lamp. Only editable if the Override is On . The O ₃ generator is controlled either by a coarse and fine pot or a DAC.
O3 Gen. Current [Serinus Cal 2000 & 3000]	0-4.9	The O ₃ generator lamp current, as determined by the pot or DAC setting.
Diagnostic Mode [Serinus Cal 3000]	Operate	<p>Operate (default): Puts the instrument in normal operation mode.</p> <p>Electrical: Injects an artificial test signal into the electronic processing circuitry on the main controller PCA to verify that the circuitry is operating correctly. When in this Diagnostic Mode, adjust the Diagnostic Test Pot from 0 to 255. This will produce a change in the concentration voltage as well as the indicated gas concentration.</p> <p>Preamp: Injects an artificial test signal into the Preamplifier mounted on the Optical Cell to verify that the Preamplifier, cabling and electronic circuitry on the main controller PCA is operating correctly. When in this Diagnostic Mode, adjust the Diagnostic Test Pot from 0 to 255. This will produce a change in the concentration voltage as well as the indicated gas concentration.</p>
Diagnostic Test Pot [Serinus Cal 3000]	0	This Digital Pot is used for diagnostics only. When in the Electrical or Preamp Diagnostic Mode , this Digital pot should be adjusted from 0 to 255. This will produce a change in the concentration voltage as well as the indicated gas concentration.
Valve Drive V Pot	0	Additional valve drive voltage pot that is used by technicians when troubleshooting.

3.5.30 Internal Pump Menu

Main Menu → Service Menu → Diagnostics Menu → Internal Pump Menu

Note this menu only appears on a Serinus Cal 3000.

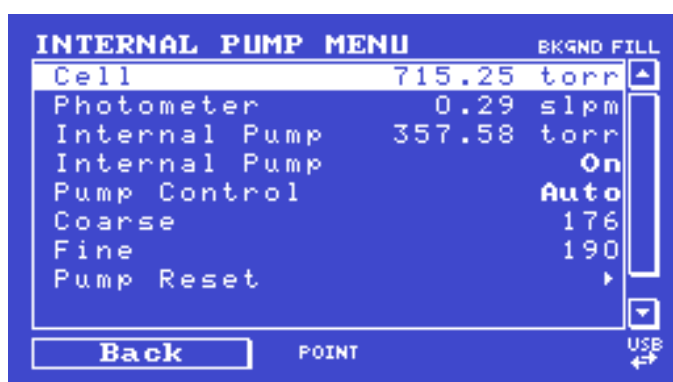

Figure 92 – Internal Pump Menu Screen

Cell [Serinus Cal 3000]	The current pressure in the photometer measurement cell.
Photometer [Serinus Cal 3000]	The current photometer gas flow.
Internal Pump [Serinus Cal 3000]	This is the pressure reading from the internal pump flow block PCA.
Internal Pump [Serinus Cal 3000]	This field allows the internal pump to be turned ON or OFF. This field is only editable when the Flow Control field is set to MANUAL.
Pump Control [Serinus Cal 3000]	Set to MANUAL to disable the automatic flow control. AUTO allows the flow PID to modify the pump coarse and fine settings. START will transition to AUTO after one second.
Coarse [Serinus Cal 3000]	Internal pump speed control (Coarse). This field is only editable when the Flow Control field is set to MANUAL.
Fine [Serinus Cal 3000]	Internal Pump speed control (Fine). This field is only editable when the Flow Control field is set to MANUAL.

3.5.31 Valve Menu

Main Menu → Service Menu → Diagnostics Menu → Valve Menu

The Valve Menu allows the user to observe the instrument-controlled switching of the valves. If the valve is ON it means the valve is energised. When a three-way valve is in the ON state it will now be in the NC (normally closed) position as shown in the plumbing schematic. When the valve sequencing is disabled, the user has the ability to turn the valve OFF and ON manually. It is recommended that the valve menu be used by a trained technician following the plumbing schematic (refer to Section).

Note: When interpreting the information below regarding the flow path through the valve note that (NC = Normally Closed), (NO = Normally Open) and (C = Common).

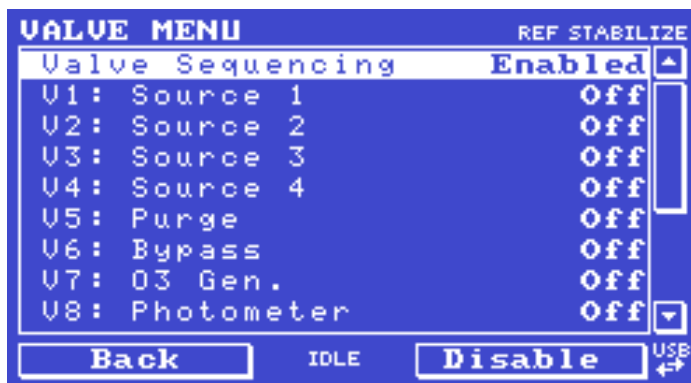

Figure 93 – Valve Menu Screen

Valve Sequencing	When Enabled the valves will open and close under instrument control (even if the user has manually opened or closed a valve). When Disabled the valves will change only in response to manual controls.
V1: Source 1	Shows the status of the valve for source port number 1.
V2: Source 2	Shows the status of the valve for source port number 2.
V3: Source 3	Shows the status of the valve for source port number 3.
V4: Source 4 or V4: Purge [Optional]	Shows the status of the valve for source port number 4. If the optional source MFC is installed this will now show the state of the purge valve.
V5: Purge or V5: Opt. Source [Optional]	Shows the status of the purge valve. If the optional source MFC is installed this will now show the state of the optional source valve.
V6: Bypass [Serinus Cal 2000 and 3000]	Shows the status of the bypass valve. This valve mixes Ozone with other gasses and is only used during a titration.
V7: O3 Gen. [Serinus Cal 2000 and 3000]	Shows the status of the Ozone generation valve.
V8: Photometer [Serinus Cal 3000]	Shows the status of the photometer valve.
V9: Opt. Source 5 [Optional]	Shows the status of the valve for source port number 5.
V10: Opt. Source 6 [Optional]	Shows the status of the valve for source port number 6.
V11: Opt. Source 7 [Optional]	Shows the status of the valve for source port number 7.
V12: Opt. Source 8 [Optional]	Shows the status of the valve for source port number 8.
V13: Dilution 2 [Optional]	Shows the status of the dilution selection valve for instruments with dual diluent option.
Diluent Supply	Shows the status of the valve supplying the diluent. This output can be used to automatically turn ON the diluent supply when it is required.

3.5.32 Tests Menu

Main Menu → Service Menu → Diagnostics Menu → Tests Menu

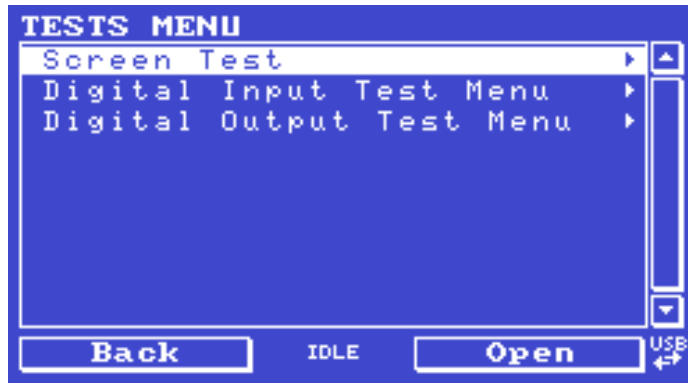

Figure 94 – Tests Menu Screen

Screen Test	Performs a screen test by drawing lines and images on the screen so that the operator can determine if there are any faults in the screen. Press a keypad key to step through the test. The up and down scrolling buttons will adjust the contrast.
Digital Input Test Menu	Refer to Section 3.5.33.
Digital Output Test Menu	Refer to Section 3.5.34.

3.5.33 Digital Input Test Menu

Main Menu → Service Menu → Diagnostics Menu → Tests Menu → Digital Input Test Menu

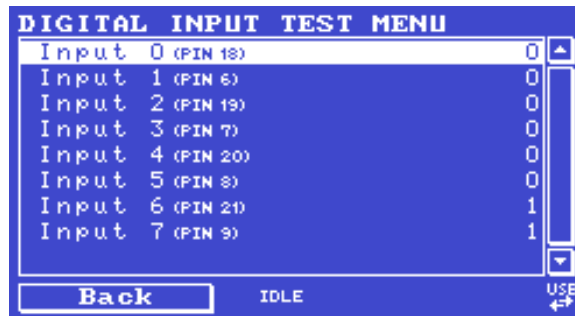

Figure 95 – Digital Input Test Menu Screen

Note: Entering the **Digital Input Test Menu** will temporarily disable the control of all digital and analog input/outputs. This will affect logging via these outputs. Exiting the menu restores automatic control.

Input 0..7	Displays the status of the 0 - 7 digital input pins. Value will be 0 or 1.
------------	--

3.5.34 Digital Output Test Menu

Main Menu → Service Menu → Diagnostics Menu → Tests Menu → Digital Output Test Menu

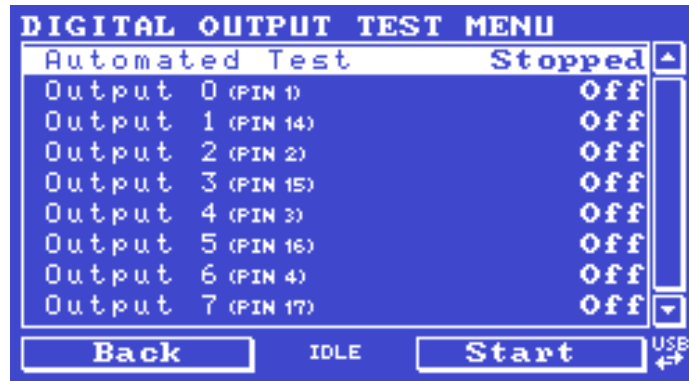

Figure 96 – Digital Output Test Menu Screen

Note: Entering the **Digital Output Test Menu** will temporarily disable the control of all digital and analog input/outputs. This will affect logging via these outputs. Exiting the menu restores automatic control.

Automated Test	Steps through each output, turning it On and Off.
Output 0..7	Displays the state of the output pin (On or Off), and allows the user to manually set the state.

3.5.35 Calculation Factors Menu

Main Menu → Service Menu → Calculation Factors Menu

Note this menu only appears on a Serinus Cal 3000.

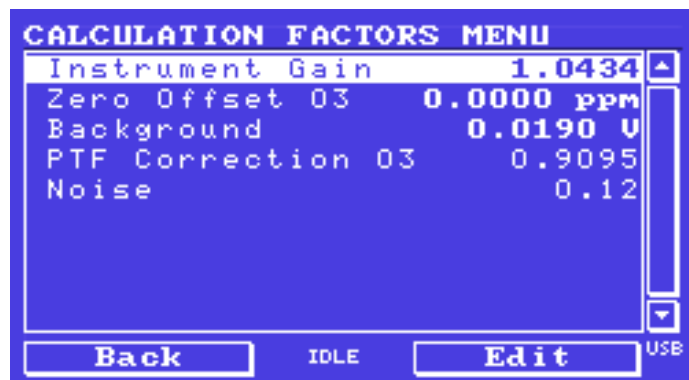

Figure 97 – Calculation Factors Menu Screen

Instrument Gain [Serinus Cal 3000]	A multiplication factor used to adjust the concentration measurement to the appropriate level (set at calibration).
Zero Offset 03 [Serinus Cal 3000]	This field displays the offset created from a zero calibration. This is the concentration measured from zero air and is subtracted from all readings.
Background [Serinus Cal 3000]	The correction factor calculated from the background cycle (used to eliminate background interferences).

<p>PTF Correction O3 [Serinus Cal 3000]</p>	<p>Displays the correction factor applied to the concentration measurement. This correction is for changes in pressure, temperature and flows since the last calibration.</p>
<p>Noise [Serinus Cal 3000]</p>	<p>The standard deviation of the concentration. The calculation is as follows: Take a concentration value once every two minutes. Store 25 of these samples in a first in, last out buffer. Every two minutes, calculate the standard deviation of the current 25 samples. This is a microprocessor-generated field and cannot be set by the user. Note: This reading is only valid if zero air or a steady concentration of span gas has been supplied to the instrument for at least one hour.</p>

3.5.36 Communications Menu

Main Menu → Communications Menu

Configures how the instrument communicates with external instrumentation and data loggers.



Figure 98 – Communications Menu Screen

<p>Data logging Menu</p>	<p>Refer to Section 3.5.37.</p>
<p>Serial Communication Menu</p>	<p>Refer to Section 3.5.38.</p>
<p>Analog Input Menu</p>	<p>Refer to Section 3.5.39.</p>
<p>Analog Output Menu [Serinus Cal 3000]</p>	<p>Refer to Section 3.5.40.</p>
<p>Digital Output Menu</p>	<p>Refer to Section 3.5.41.</p>
<p>Network Menu [Optional]</p>	<p>Refer to Section 3.5.42.</p>
<p>Bluetooth Menu</p>	<p>Refer to Section 3.5.43.</p>

3.5.37 Data Logging Menu

Main Menu → Communications Menu → Data Logging Menu

When editing the numeric or text menus, the “-” key will delete the current parameter and move the others up to take its place; the “+” key will insert a parameter at the current location and move the ones below it down. The internal logger can log a maximum of 12 parameters.



Figure 99 – Data Logging Menu Screen

Data Log Interval	Displays the interval at which the data is saved to the USB memory stick. Selecting 1 sec interval may result in occasional measurements not being logged or slow response to serial commands.
Data Log Setup –Numeric	Numeric list of the parameters logged. This is a quicker way to enter parameters (for lists of parameters refer to Table 51).
Data Log Setup –Text	Select the list of logged parameters by name.

3.5.38 Serial Communication Menu

Main Menu → Communications Menu → Serial Communications Menu



Figure 100 – Serial Communication Menu Screen

Serial ID	This is the ID of the instrument when using Multidrop RS232 communications. This ID can be changed to support multiple instruments on the same RS232 cable. The default is 1, 2 and 3 for the 1000, 2000 and 3000 respectively.
Bayern-Hessen Serial ID [Bayern-Hessen Protocol]	This is the Bayern-Hessen ID used by the Bayern-Hessen Protocol.
O3 ID [Bayern-Hessen Protocol]	This is the ID of the O3 gas used by the Bayern-Hessen Protocol.

[Serinus Cal 3000]	
Service port (RS232 #1) Multidrop port (RS232 #2)	The port parameters below are repeated for each serial port.
Serial Delay	Some older communications systems require a delay before the analyser responds to a serial command. Enter the number of milliseconds of delay required here (0 - 1000). The default is 0, meaning the analyser responds as quickly as possible to any serial request.
Baudrate	Sets the baud rate for this serial port (1200, 2400, 4800, 9600, 14400, 19200, 38400, or 115200).
Parity	This controls the Parity of RS232 communication. This should be left at the default None , unless your system requires otherwise.
Protocol	Sets the protocol used for this serial port (Advanced, ModBus, EC9800, Bayern-Hessen or GasCal). This must be set to Advanced for Acoem supplied software.
Endian [Modbus Protocol]	Select Little or Big endian mode for ModBus protocol.

3.5.39 Analog Input Menu

Main Menu → Communications Menu → Analog Input Menu

The Serinus supports 3 analog inputs from the 25 pin I/O connector. Each input is a 0 to 5 volt CAT 1 input that can be scaled and logged to the internal memory, or accessed remotely as parameters 199 - 201.



CAUTION
Exceeding these voltages can permanently damage the instrument and void the warranty.



Figure 101 – Analog Input Menu Screen

Analog Dew Point	The instrument has a diluent Dew Point option installed. Default is Disabled.
Input 1/2/3	The sections below are repeated for each analog input.
Multiplier	The input voltage will be multiplied by this number. For example, if a sensor has a 0 - 5 V output for a temperature of -40 °C to 60 °C, the multiplier would be $(60 - (-40))/5 = 20$.
Offset	This value will be added to the above calculation. Continuing the example in the multiplier description, the offset should be set to -40, so that a voltage of 0 V, will be recorded as -40 °C.
Reading	The current reading from the input voltage, after the multiplier and offset has been applied. This is the value that is logged or reported as parameter 199 - 201 via USB or serial requests.

3.5.40 Analog Output Menu

Main Menu → Communications Menu → Analog Output Menu

Note this menu only appears on a Serinus Cal 3000.

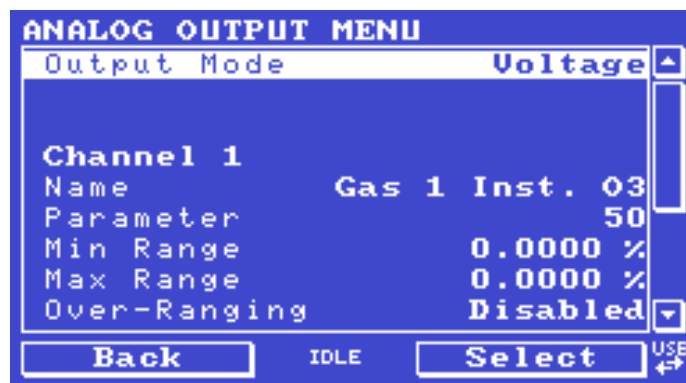

Figure 102 – Analog Output Menu Screen

Output Mode	The analog output can be set to be either Current or Voltage. Different fields will be displayed depending on which analog output type is selected.
Channel 1	Channel 1 as default will be setup to be Parameter 50, which is O3 instantaneous reading. This Channel can be user defined to any of the available parameters (for a list of parameters refer to Table 51). IF the user has the optional MFC source this option will not be available.
Name	Text list of the parameter defined to output through the analog output (for a list of parameters refer to Table 51).
Parameter	Numeric list of the parameter defined to output through the analog output. This is a quicker way to enter parameters (for a list of parameters refer to Table 51).
Min Range	Sets the lower range limit (in concentration units). This is the value at which the analog output should be at its minimum. For example, 4 mA for a 4 to 20 mA current output.
Max Range	Sets the upper range limit (in concentration units). This value can be edited but cannot exceed the Over Range value. This is the value at which the analog output should be at its maximum. For example, 20 mA for a current output.
Over-Ranging	Set to Enabled or Disabled to turn the over-ranging feature ON or OFF.

Over-Range	This field is only editable when Over-Range is set to Enabled . Set to the desired over range value. This value cannot be set below the Range value. This is the alternate scale the used for the analog output when over-ranging is active and enabled. When 90 % of the standard range is reached, this over range is automatically entered. When 80 % of the original range is reached, it returns to the original range.
Hold for Cal.	

3.5.40.1 Analog Output Menu - Voltage

Main Menu → Communications Menu → Analog Output Menu

These items appear when **Output Mode** is set to **Voltage**.

Voltage Offset	Choices are 0 V, 0.25 V, and 0.5 V. This sets the voltage for a reading of 0. Since the output cannot go negative, this offset can be used to record negative readings.
0.5V Calibration	Enables the user to calibrate the analog output at a low point. Increase/decrease the value until the connected equipment reads 0.5 V.
5.0V Calibration	Enables the user to calibrate the analog output at maximum output (5 V). Increase/decrease the value until the connected equipment reads 5 V.

3.5.40.2 Analog Output Menu - Current

Main Menu → Communications Menu → Analog Output Menu

These items appear when **Output Mode** is set to **Current**.

Current Range	Enables the user to set desired current ranges. Choices are 0 - 20 mA, 2 - 20 mA or 4 - 20 mA.
4mA Calibration	Enables the user to calibrate the current output at a low point. Increase/decrease the value until the connected equipment reads 4 mA.
20mA Calibration	Enables the user to calibrate the current output at a full scale point (20 mA). Increase/decrease the value until the connected equipment reads 20 mA.

3.5.41 Digital Output Menu

Main Menu → Communications Menu → Digital Output Menu

The digital outputs are shared among digital alarms and point and sequence definitions. A digital output that is designated as a digital alarm will display an **R** instead of a **0**, **1**, or **X** in the digital mask.

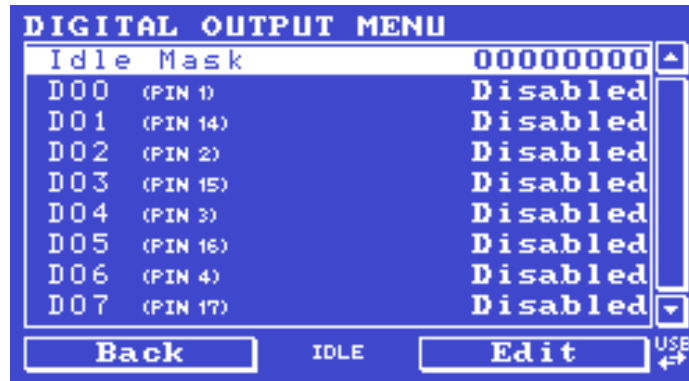

Figure 103 – Digital Output Menu Screen

Idle Mask	This is the state of the digital outputs when the instrument is IDLE. When the instrument is running a point or sequence, the digital output masks for the point, sequence, and digital alarms will be combined (OR operation) with this pattern (any bit that is a 1 in either this mask, the point mask, the sequence mask, or the a digital alarm will be set to 1).
DO N (Pin X)	Associates a state with a digital output. There are 8 digital outputs (the pin numbers are for the 25-pin connector). Each one can have one of the associated states listed in Table 4 – Digital Output States. The pin will be driven high while the analyser is in that state. If a pin is set to anything other than Disabled , that pin will not be available for point or sequence masks.
Active	Each pin can be set to be active High or Low . Active High means that the pin will be pulled to 5 V when the associated event occurs. Active Low means the pin will be pulled to 0 V when the associated event occurs.

Table 4 – Digital Output States

Digital Output State	Description
Disabled	No state (this output is never set high).
Pwr Supply Fail	Power supply fault.
Ref Volt. Fail	Reference voltage fault.
A2D Fail	Analog to digital fault.
Lamp Fail	Lamp fault.
Flow Fail	Photometer flow fault.
Flow Heat Fail	Flow block heater fault.
Lamp Heat Fail	Lamp heater fault.
Chassis Tmp Fail	Chassis temperature fault.
USB Disconnected	The USB memory stick is not communicating.
Background	Performing a background.
Span	Performing a span check.

Digital Output State	Description
Zero	Performing a zero check.
System Fault	Any system fault (the red light is ON).
Diluent Flow Fault	A diluent flow fault.
Source Flow Fault	A source flow fault.
Ozone Flow Fault	An Ozone flow fault.
Maintenance Mode	User has activated maintenance mode.
Over Range AO 1	Over range for analog output 1 is active.

3.5.42 Network Menu (Optional)

Main Menu → Communications Menu → Network Menu

The **Network Menu** only appears when the **Network Port** is enabled (refer to **Hardware Menu**, Section 3.5.47). The **Network Menu** allows the user to view or set the I.P. address, Netmask and Gateway if the optional network port is installed.

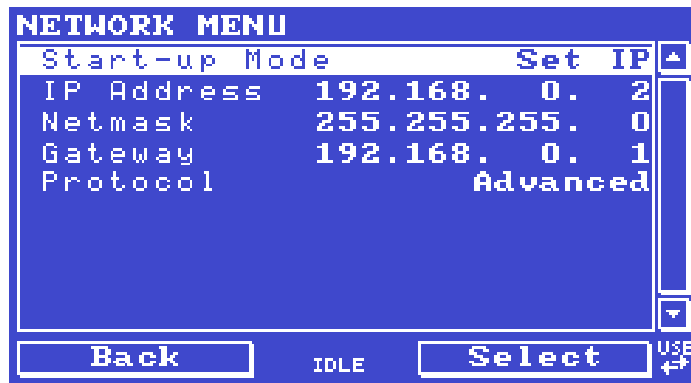

Figure 104 – Network Menu Screen

Start-up Mode	<p>The following modes are available:</p> <p>NORMAL: In this mode nothing is done with the network port during boot-up. It is assumed to be configured correctly or unused.</p> <p>READ IP: This mode interrogates the network port for its IP address. The menu will display the network address after boot-up.</p> <p>SET IP: The user may enter an IP address, Netmask, and Gateway address (following the usual rules for formatting these addresses). Note that at this time the instrument does not validate the correctness of these entries.</p> <p>When the user cycle power, the instrument will first instruct the network port on its new address. It will switch to Read IP mode and read back the address it just set so that the user may verify it in the menu.</p> <p>Set DHCP: This sets the network port into DHCP mode, allowing the network to assign the instrument an IP address.</p>
IP Address [Read IP or Set IP Start-up Mode]	This is the current IP address of the instrument.

Netmask [Read IP or Set IP Start-up Mode]	This is the subnet mask of the network the instrument is connected to.
Gateway [Read IP or Set IP Start-up Mode]	This is the IP address of the router to access addresses not on the same subnet.
ID [Set DHCP Start-up Mode]	This is the ID of the instrument. Use the keypad to edit this field. The default ID setting is Serinus(Acoem ID) . The word Serinus is always the first part of the name and cannot be edited. The second part is the Acoem ID .
Adaptor is in DHCP mode [Set DHCP Start-up Mode]	In this mode the instrument will ask for its network parameters from a DHCP server on your network.
Protocol	Sets the protocol used for the network port (Advanced, ModBus, EC9800, Bayern-Hessen or GasCal). This must be set to Advanced for Acoem supplied software.
Endian [Modbus Protocol]	Select Little or Big endian mode for ModBus protocol.
Bayern-Hessen Serial ID [Bayern-Hessen Protocol]	This is the Bayern-Hessen ID used by the Bayern-Hessen Protocol.
O3 ID [Bayern-Hessen Protocol] [Serinus Cal 3000]	This is the ID of the O3 used by the Bayern-Hessen Protocol.

To read the IP address, refer to Section 4.3.1.

To set the IP address, refer to Section 4.3.2.

3.5.43 Bluetooth Menu (Optional)

Main Menu → Communications Menu → Bluetooth Menu

Serinus Cal instruments support Bluetooth communication through the Serinus Remote Android Application (refer to Section 4.8).

Note: If the user has security concerns about the Bluetooth, it can be disabled by disconnecting the ribbon cable connecting the Bluetooth module to the main controller PCA. This will disable the Bluetooth and remove the Bluetooth menu item from the communications menu after a power cycle.



Figure 105 – Bluetooth Menu Screen

Bluetooth	This field indicates whether the instrument is remotely connected to an Android device.
Reset	After changing the ID or PIN, it is necessary to reboot the Bluetooth module. This is done by resetting the instrument or by using this menu item to reboot only the Bluetooth.
ID	<p>This is the Bluetooth ID of the instrument. Use the keypad to edit this field (refer to Section 3.3.1 for instructions on entering text with the numeric keypad).</p> <p>The default ID setting is Serinus(Acoem ID).</p> <p>Note: The word Serinus is always the first part of the name and cannot be edited. The second part is the Acoem ID.</p>

3.5.44 Trend Display Menu

Main Menu → Trend Display Menu



Figure 106 – Trend Display Menu Screen

Parameter	Allows the user to select a parameter from 0 - 251 to graph on the trend display.
Name	Displays the name of the Parameter the user has selected.
Autoscale	Autoscale can be ON or OFF. When it is “On” the parameter will be scaled automatically for user convenience based on the current values logged.
Min	This is the minimum scale of the chart as defined by the Autoscale or the user.
Max	This is the maximum scale of the chart as defined by the Autoscale or the user.
Clear	Clears the current data points in the Chart .
Data Log Interval	The data log interval can be user set from 1 sec interval up to 24 hours.
Chart	This field enters a screen with a graph of the user selected Parameter (Refer to Section 3.5.45).

3.5.45 Chart

Main Menu → Trend Display Menu → Chart

The chart allows the user to select a parameter and view it in a real time chart. The user can select from any loggable parameter (refer to Table 51). Changing the logged parameter will reset the chart. However, up to the first four Instantons gas and Ozone values are always memorized. Changing the Data Log Interval resets all charts.

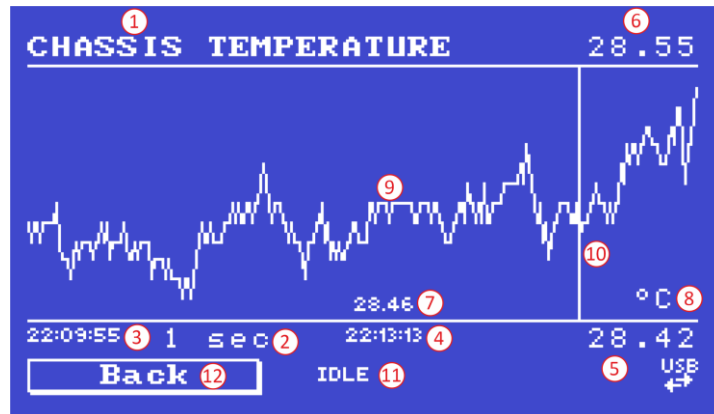

Figure 107 – Chart Screen

Chart Title (1)

Displays the name of the parameter as it would be displayed on the advanced protocol parameter list.

Data Log Interval (2)

Displays the value of the data logging interval as determined by the user in the **Trend Display Menu** (refer to Section 3.5.44).

Chart X-Axis (3 & 4)

(3) Displays the time stamp for the oldest data point (left hand side).

(4) Displays the time stamp for the newest data point (right hand side) or if the cursor is active it displays the current cursor data point time stamp.

Chart Y-Axis (5 & 6)

(5) This is the minimum scale as defined by the autoscale or the user (refer to section 3.5.44).

(6) This is the maximum scale as defined by the autoscale or the user (refer to section 3.5.44).

Current Data Point Value (7)

Displays the current value of the newest data point unless the **cursor** is active then it displays the current cursor data point value.

Units (8)

Displays the units of measure for the parameter that the user has selected.

Data Points (9)

Displays the last 240 data points recorded for the selected parameter.

Chart Cursor (10)

If the user wishes to know the value at any at a particular data point on the chart, the cursor can be used. The cursor is activated by pressing the (-) key on the keypad and is represented by a vertical line on the chart. The cursor can be moved left or right by the (-) or (+) key respectively. This cursor location now represents the current data point value of interest. The cursor will stay with the chosen data point and move with the updating chart. When the cursor finally hits the end of the chart it deactivates and the current data point value will now be the latest data point entering the chart.

Mode (11)

This Field indicates the mode the instrument is currently running.

Back (12)

Pressing back allows the user to access other menu items while the chart is still logging in the background.

Digital Output State	Description
Left Selection Button	Returns the user back to the trend display menu.
Scrolling Buttons	Using the scrolling buttons will cycle through the user selected parameter as well as any default gas(es) currently logging.
- Button	Pressing the (-) button will bring up the cursor and move it to the left.
+ Button	Pressing the (+) button will move the cursor to the right. When the cursor moves all the way to the right due to the chart moving it will deactivate.

3.5.46 Advanced Menu

This menu is accessed via a different method than the other menus. From the **Home Screen** press the following keys:



This menu contains technical settings, diagnostics and factory hardware installations. No items in this menu should be accessed without authorisation and supervision of qualified service personnel.



Figure 108 – Advanced Menu Screen

Language	Select a language.
Hardware Menu	Refer to Section 3.5.47.

Service Displays	When set to On , new items appear on many different menus. These fields are for diagnostic and service personnel only. Default is Off .
Next Service Due	Enter the next service due date.
Jump to Next State [Serinus Cal 3000]	Move to the next mode (for example, from fill to measure). This command is most commonly used to force an instrument out of warm-up early.
Parameter Display Menu	Refer to Section 3.5.49.
Reset to Factory Defaults	Reset the configuration to factory defaults. This will erase all calibrations and user configuration information.
Rebuild Index	If a data log becomes corrupted it may be possible to restore it by rebuilding its index file. This command will ask the user to specify a month and will rebuild the index for that month. This operation can take many minutes and it should not be interrupted. While the file is rebuilding any data logging will be suspended.

3.5.47 Hardware Menu

Advanced Menu → Hardware Menu

This menu contains factory hardware installations. If the user reset to factory defaults, then they may need to revisit this menu to re-install optional features.



Figure 109 – Hardware Menu Screen

Model	Select the instrument model. Normally this only needs to be reset when the configuration is corrupted. The selections available will depend on licensing. It is not recommended to run an instrument with firmware set to an incorrect model.
Front Panel Style	Choosing the incorrect front panel will result in the traffic lights behaving inconsistently. Default is Aluminium .
Network Port	The instrument has a network port. Default is Disabled .
Orifice Size [Serinus Cal 3000]	Specify the input orifice for the calibrator. Note that unlike the Serinus line of analysers, the Serinus Cal 3000 uses both an orifice and an internal pump. Default is 0.3 .
Analog Dew Point	The instrument has a diluent Dew Point option installed. Default is Disabled .

Ozone Lamp [Serinus Cal 2000 & 3000]	Specifies the type of lamp used in the ozone generator. Default is Standard .
Warm O3 Gen. [Serinus Cal 2000 and 3000]	If Enabled , keeps the O3 Gen lamp at a minimum voltage even when not being used. Keeping the lamp warm will improve Ozone response time. Default is Disabled . Please note that during an Ozone Zero point (when the instrument has been instructed to produce 0.0 Ozone concentration) the lamp will be turned completely OFF, regardless of this setting.
MFC Installation Menu	Refer to Section 3.5.48.
Dual Diluent Valve	If Enabled , allows the calibrator to select between two diluents. Default is Disabled .
Optional Source	If Enabled , allows the four additional input valves V5-V8. Default is Disabled .
Ozone MFC Control [Serinus Cal 2000]	Serinus Cal 2000 can be reconfigure to use an MFC for Ozone flow control. Defaults is Disabled .
Shielded Bench [Serinus Cal 3000]	The instrument has a shielded bench. Default is Disabled .

3.5.48 MFC Installation Menu

Advanced Menu → Hardware Menu → MFC Installation Menu

Select an MFC by capacity (i.e. **50 SCCM**) from the list of supported capacities. When an MFC is selected, the polynomials for its calibration will be displayed along with its corresponding readout calibration.

MFC Source	This is the primary source MFC calibration Co-efficient.
MFC Opt Source	This is the optional source MFC. The microprocessor will select the correct MFC to use based on the concentration requested and the capacity of the MFC.
MFC Diluent	The primary diluent MFC.
MFC Opt Diluent	Optional diluent MFC. Will be used when the primary MFC cannot accurately supply the requested flow.
(Repeated)	The sections below are repeated for each MFC.
MFC n	This is the label for one of the 4 potential MFC's available. When the optional MFC's are set to "None" they will not display any of their co-efficient values.
Coeff. A0	Co-efficient for MFC.
Coeff. A1	Co-efficient for MFC.
Coeff. A2	Co-efficient for MFC.
Readout Calibration	Each available MFC will have its own Correction Co-efficient for the MCF readout.
Coeff. A0	Co-efficient for Readout calibration.
Coeff. A1	Co-efficient for readout calibration.
Coeff. A2	Co-efficient for readout calibration.

3.5.49 Parameter Display Menu

Advanced Menu → Parameter Display Menu

Used to display a parameter in real-time on the screen (refer to Table 51 for a full list of parameters).

Data Parameter	Enter the advanced protocol parameter number.
Name	Displays the name of the selected parameter.
Value	Displays the current value of the selected parameter.

This page is intentionally blank.

4. Communications

The Serinus has a number of different interfaces for communication with other equipment (RS232, USB, 25 pin digital/analog input/output, TCP/IP network (optional)/Diluent Control and Bluetooth). A demonstration version of Acoem's Airodis software is included with the instrument, enabling basic data downloads and remote operation from a PC running a supported MS Windows operating system. The full version of Airodis is available separately, and includes automated collection, data validation, and complex reporting by multiple users. Refer to the Airodis Manual and Section 4.7 of this manual for details on setting up and communicating with the Serinus.

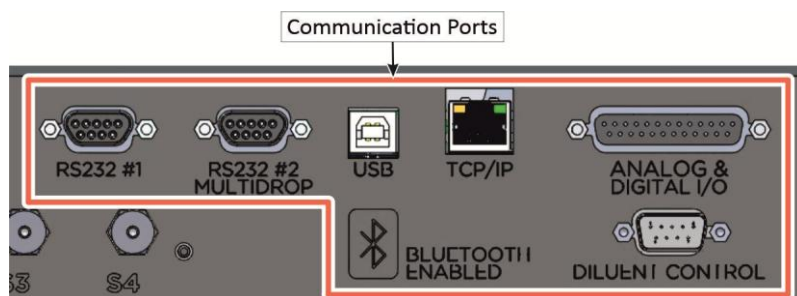

Figure 110 – Communication Ports

4.1 RS232 Communication

RS232 communication is a very reliable way to access data from the instrument, and is recommended for use in connection to a data logger for 24/7 communication. Both RS232 ports are configured as DCE, and can be connected to DTE (Data Terminal Equipment such as a data logger or computer).

Port #2 also supports a multidrop arrangement (a configuration of multiple analysers connected via the same RS232 cable where the transmit signal is only asserted by the instrument that is spoken to).

For reliable Multidrop RS232 communications follow these guidelines:

- Verify that the Multidrop ID is set to a unique value which is different to the other analysers in the chain (refer to **Serial Communication Menu**, Section 3.5.38).
- All of the analysers in the multidrop chain must have the same baud rate and communication protocol settings. A maximum of 9600 baud is recommended.
- The Multidrop RS232 cable should be kept to less than 3 meters in length.
- A 12K ohm terminating resistor should be placed on the last connector of the cable. (connect from pin 2 to pin 5 and from pin 3 to pin 5) (Refer to Figure 111).
- The shielding of the Multidrop cable must be continuous throughout the cable.
- The shielding of the Multidrop cable must only be terminated at one end. It should be connected to the metal shell of the DB 9-way connector.

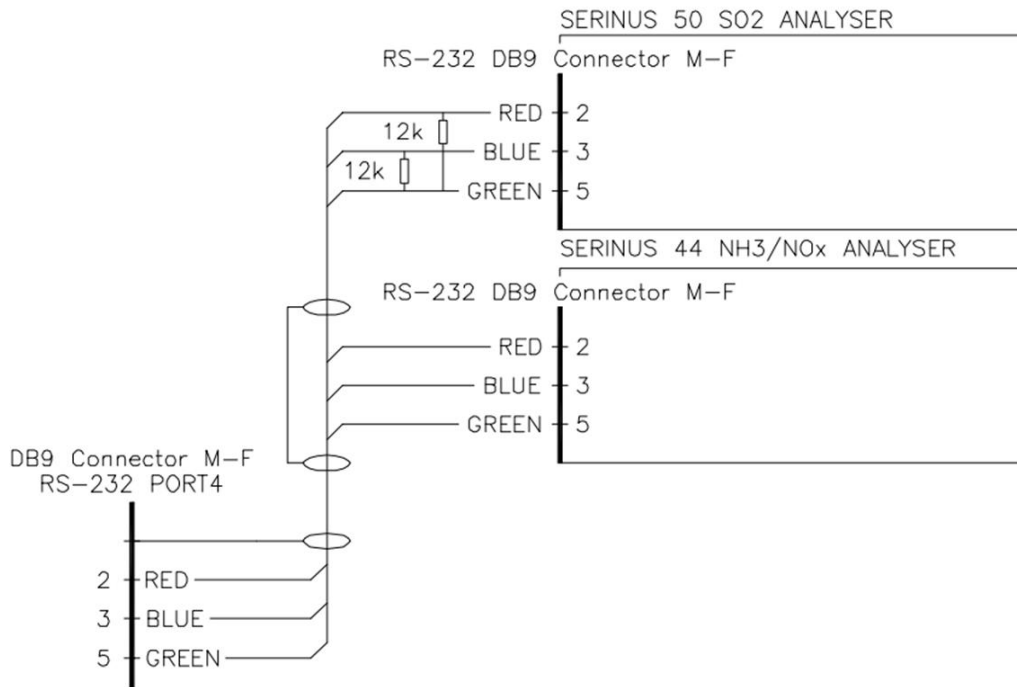

Figure 111 – Multidrop RS232 Cable Example

4.2 USB Communication

This is ideal for irregular connection to a laptop running Acoem’s Airodis software to download logged data and remotely control the instrument. Due to the nature of USB, this is a less reliable permanent connection as external electrical noise can cause USB disconnection errors on a data logger.

For more information on regarding connecting over USB, making connections refer to Section 4.7.1.1.

Note: Only the Advanced protocol is supported for USB communication.

4.3 TCP/IP Network Communication (Optional)

Instruments with the optional network port installed can be accessed using a TCP/IP connection. Figure 112 shows examples of some possible configurations for remote access.

Direct Connection

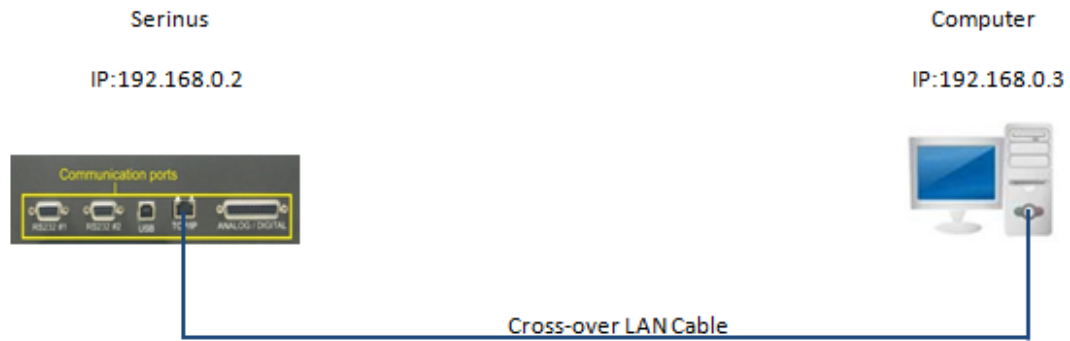

LAN

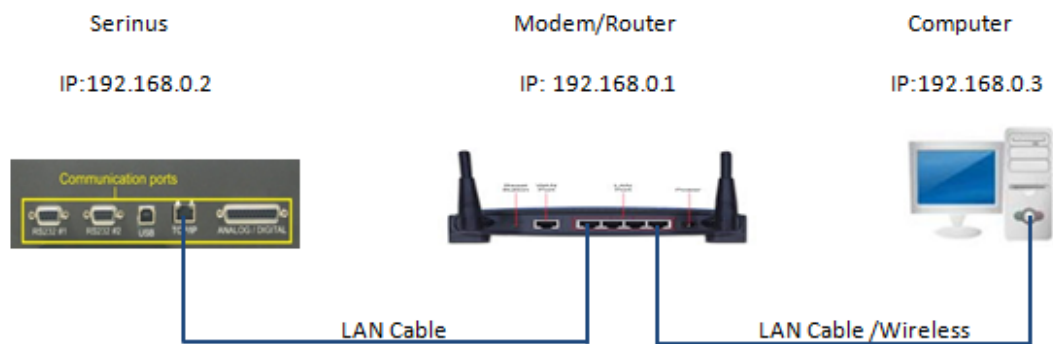

WAN

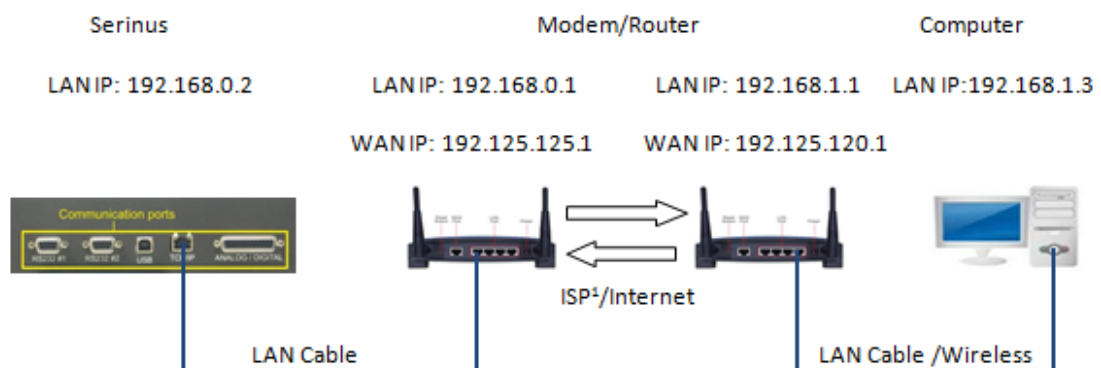

¹ ISP: Internet Service Provider

Figure 112 – Example of Typical Network Setups

Note: In Figure 112 all the IP addresses are taken as an example. The WAN IP addresses are normally provided by your ISP. Whereas, the LAN IP addresses can be set manually to any range which is within the subnet of the Modem/Router/switch.

Use a cross-over LAN cable to connect the instrument directly to a computer, or a standard LAN cable for connection to a Modem/Router/Switch as shown in Figure 112. The computer could be connected to the Modem/Router using either CAT5 cable or a wireless connection, but the instrument must be connected using CAT5/6 cable.

4.3.1 Reading Network Port Setup

To read the current network port settings perform the following steps:

Procedure

1. Open - **Main Menu** → **Communications Menu** → **Network Menu**.
2. Select - **Start-up Mode** → **Read IP** - Accept.
3. Manually use the power switch on the rear of the instrument to turn the power OFF. Leave the instrument OFF for 10 seconds before turning the power back ON.
4. Open - **Main Menu** → **Communications Menu** → **Network Menu**.
5. The current network port settings will now be displayed on the screen.
6. When viewing is complete select - **Start-up Mode** → **Normal** - Accept.

4.3.2 Setting Network Port Setup

Below is an example of how-to setup the network port:

Procedure

1. Open - **Main Menu** → **Communications Menu** → **Network Menu**.
2. Select - **Start-up Mode** → **Set IP** - Accept.
3. Edit - **IP Address** - (Change the IP address to the address the user wishes to use within the Modem/Router/Switch Subnet).
4. Edit - **Netmask** - (Change the Netmask to the setup specified by the Modem/Router).
5. Edit - **Gateway** - (Change the Gateway to the setup specified by the Modem/Router).
6. Select - **Protocol** → **Advanced** - Accept.



Figure 113 – Example of Network Menu Setup

7. Once completed, use the power switch on the rear of the instrument to turn the power OFF. Leave the instrument OFF for 10 seconds before turning the power back ON.

Note: Manually perform a hardware power cycle every time the IP address is changed for it to take effect.

8. Open - **Main Menu** → **Communications Menu** → **Network Menu**.
9. The **Start-up Mode** automatically changes to **Read IP** and the current network port settings will be displayed on the screen.
10. When viewing is complete select - **Start-up Mode** → **Normal** - Accept.

4.3.3 Port Forwarding on Remote Modem/Router Setup

When using the network port to connect to the router/modem with NAT enabled, the user will need to add IP mapping to ensure that data is forwarded through to the desired port. This is known as port forwarding. To set-up the port for the instrument, the user needs to go into the modem/router configuration. Normally, the user will see the port forwarding setup under Port Forwarding, NAT or Port Mapping menu. Below is an example port forwarding setup.

The default port for the Serinus range of instruments is **32783**. The destination address is the instrument IP address setup in the **Network Menu**.

Item	Protocol	Incoming Address	Incoming Port	Destination Address	Destination Port
1	tcp	0.0.0.0	32783 - 32783	192.168.0.2	32783 - 32783

Figure 114 – Port Forwarding Example

4.3.4 Setup Airodis to Communicate with Serinus

LAN

Below is an example of Airodis setup for a LAN network. Ensure the IP address is set to the same as on the instrument **Network Menu**.

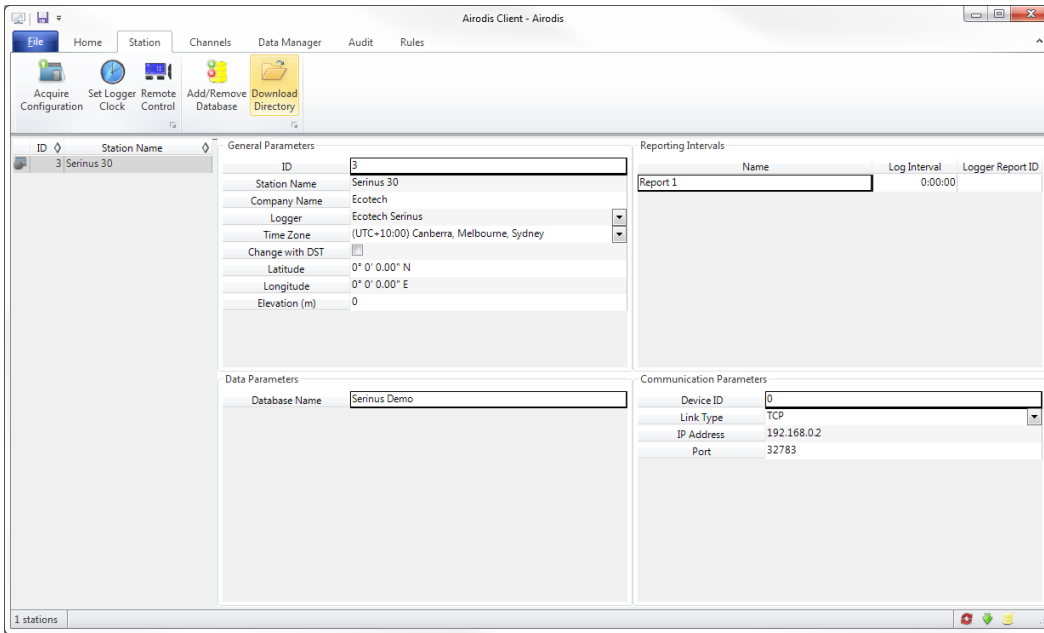

Figure 115 – LAN Network Set-Up (Airodis)

WAN

Below is an example of Airodis setup for a WAN network. Ensure the IP address is set the same as on the remote modem/router.

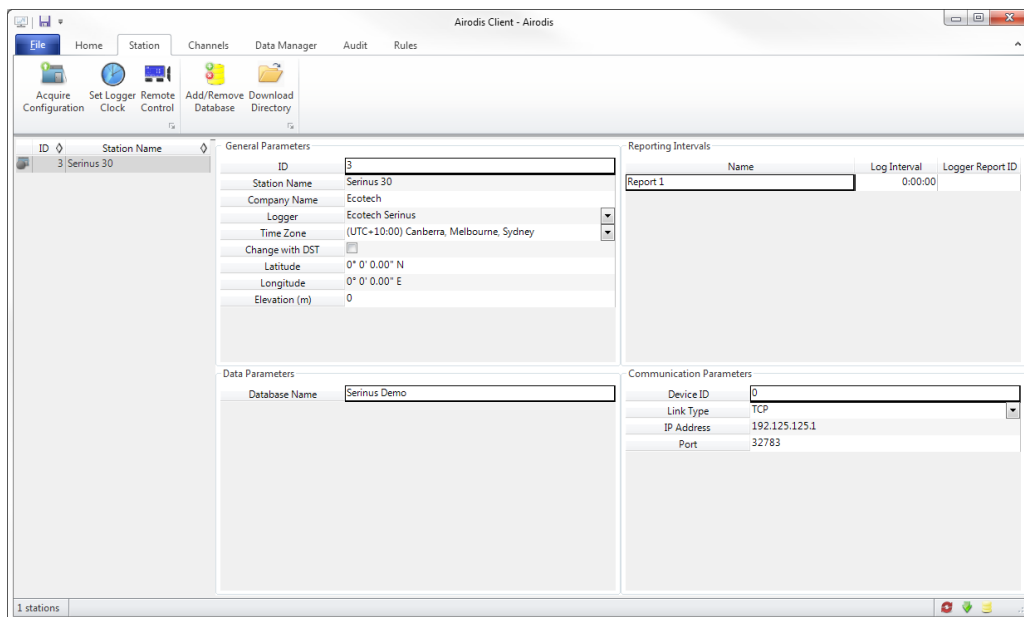

Figure 116 – WAN Network Set-Up (Airodis)

4.4 Analog/Digital Communication

The 25 Pin analog/digital port on the rear panel of the instrument sends and receives analog/digital signals to other devices. These signals are commonly used for warning alarms.

4.4.1 Analog Outputs

Analog outputs only available on a Serinus Cal 3000. Serinus CAL 3000 is equipped with one analog outputs that can be set to provide either voltage (0 - 5 V, 0.25 - 5 V, 0.5 - 5 V, 0 - 10 V) or current (0 - 20, 2 - 20, 4 - 20 mA). The analog outputs are tied to user selected parameters (refer to Table 51).

For 0 - 10 V analog output operation, set the output type to current and move the jumpers (JP3) on the rear panel PCA to 0 - 10 V (refer to Figure 117). Ensure the Current Range is set to 0 - 20 mA to obtain the 0 - 10 V range. When calibrating the (current) analog output with the jumper set to 0 - 10 V, the 4 mA calibration target is now a 2 V target and 20 mA calibration target is now a 10 V target.

Note: When the second source MFC option is enabled, analog outputs will no longer be available.

4.4.1.1 Analog Outputs Voltage Calibration

Equipment Required

- Multimeter (set to volts)
- Male 25 pin connector with cable

Procedure

1. Open - **Main Menu** → **Communications Menu** → **Analog Output Menu** (refer to Section 3.5.40).
2. Select - **Output Mode** → **Voltage**.
3. Connect a multimeter (using an appropriate adaptor or probes on the multimeter) to the ground (pin 24) and the relevant output pin (pin 23).
4. Edit - **0.5V Calibration** - (until the multimeter reads $0.500\text{ V} \pm 0.002$) - Accept.
5. Edit - **5.0V Calibration** - (until the multimeter reads $5.00\text{ V} \pm 0.002$) - Accept.

4.4.1.2 Analog Outputs Current Calibration

Equipment Required

- Multimeter (set to mA)
- Male 25 pin connector with cable

Procedure

1. Open - **Main Menu** → **Communications Menu** → **Analog Output Menu** (refer to Section 3.5.40).
2. Select - **Output Mode** → **Current**.
3. Connect a multimeter (using an appropriate adaptor or probes on the multimeter) to the ground (pin 24) and the relevant output pin (pin 23).
4. Edit - **4mA Calibration** - (until the multimeter reads $4\text{ mA} \pm 0.01$) - Accept.
5. Edit - **20mA Calibration** - (until the multimeter reads $20\text{ mA} \pm 0.01$) - Accept.

4.4.2 Analog Inputs

The instrument is also equipped with three analog inputs with resolution of 15 bits plus polarity, accepting a voltage between 0 - 5 V. These go directly to the microprocessor and should be protected

to ensure static/high voltage does damage the main controller PCA (instrument warranty does not cover damage from external inputs).

4.4.3 Digital Status Inputs

The instrument is equipped with eight logic level inputs for the external control of the instrument such as Zero or Span sequences. Each input has a terminating resistor which can be either PULL UP or PULL DOWN. This is set using the jumper JP1 on the rear panel PCA (refer to Figure 117).

4.4.4 Digital Status Outputs

The instrument is equipped with eight open collector outputs which will convey instrument status condition warning alarms such as no flow, sample mode, etc. Two of the digital outputs can be set so that there is +5 V and +12 V available on the 25 pin connector for control purposes, instead of digital outputs 0 and 1.

In the default jumper locations (refer to Figure 117) these two outputs will function normally as open collector outputs. If moved to the position closer to the 25 pin connector then the DO 0 will supply +12 V and DO 1 will supply +5 V.

The +12 V and +5 V supplies are limited to about 100 mA each.

Each digital output is limited to a maximum of 400 mA. The total combined currents should not exceed 2 A.

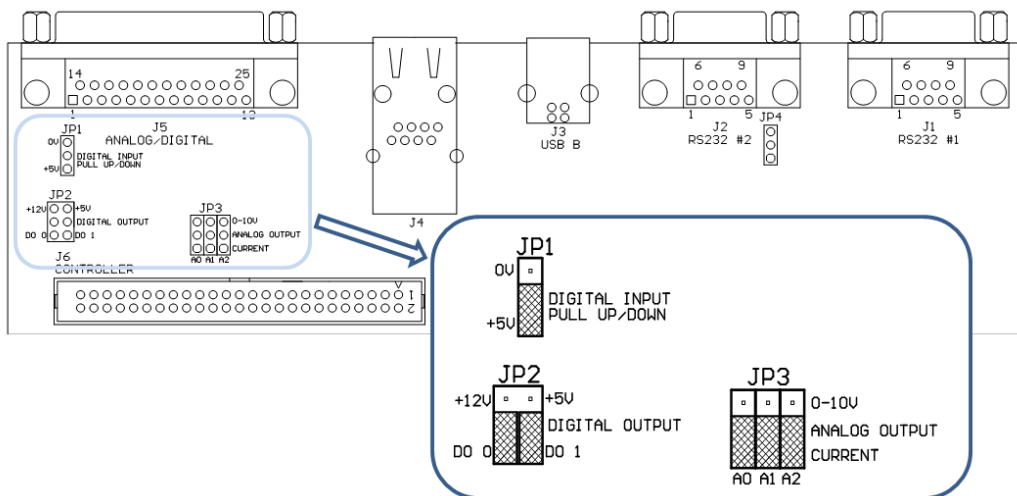

Figure 117 – 25 Pin Rear Panel PCA (Default Jumpers Highlighted)

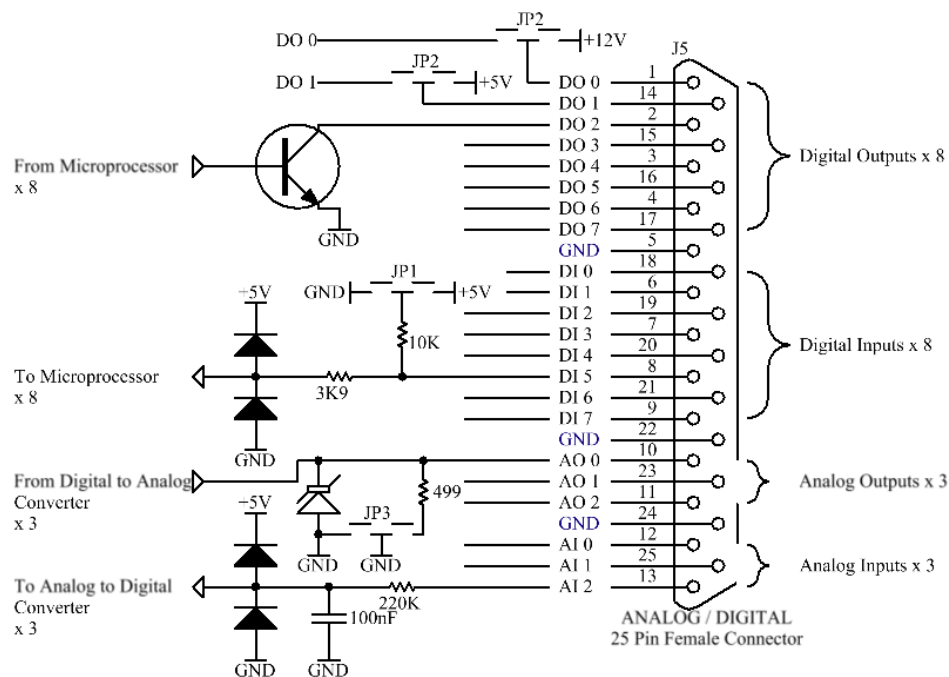

Figure 118 – Analog & Digital I/O Individual Pin Descriptions



CAUTION

The analog and digital inputs and outputs are rated to CAT I. Exceeding 12VDC or drawing greater than 400mA on a single output or a total greater than 2A across the 8 outputs can permanently damage the instrument and void the warranty.

4.5 Diluent Control

This port is used to control an external Zero Air Generator (such as the Acoem Australasia 8301LC) by providing a 12 V signal when the Diluent is required.

4.6 Logging Data

When the user receives the instrument from the factory it will have a default set of parameters already setup in the internal data logger. These select few parameters have been chosen for their relevance in assisting in troubleshooting the instrument.

4.6.1 Configure Instrument Internal Logging

In order to log data the user must first specify a data logging interval. This is how often data will be logged to the USB memory stick. It is possible to log a maximum of 12 parameters. These parameters can be selected by name or by parameter number using the parameter list as a reference (refer to Table 51).

4.6.1.1 Data Log Setup –Numeric

Procedure

1. Open - **Main Menu** → **Communications Menu** → **Data Logging Menu** (refer to Section 3.5.37).

2. Select - **Data Log Interval** - (adjust to the desired value) - Accept.
3. Open - **Data Log Setup –Numeric** - (select the storage location to edit).
4. Edit - (Change the value in the selected storage location “Parameter n” to the preferred parameter to be logged) - Accept.

4.6.1.2 Data Log –Text

Procedure

1. Open - **Main Menu → Communications Menu → Data Logging Menu** (refer to Section 4.6.1.2).
2. Select - **Data Log Interval** - (adjust to the desired value) - Accept.
3. Open - **Data Log Setup –Text** - (select the storage location).
4. Select - (Change the name in the selected storage location “Parameter n” to the preferred parameter to be logged) - Accept.

4.7 Using Airodis Software to Download Data

4.7.1 Connecting the Serinus to a PC

This instrument can communicate with a PC using RS-232 (Serial), TCP/IP (Network), Bluetooth or USB. Serial, Bluetooth and network communications do not require additional drivers. When using a USB connection, the driver must be installed first.

4.7.1.1 Connecting over USB

Before connecting the USB cable from a PC to the instrument, the Serinus USB driver must be installed.

1. Power ON the instrument and connect it to a PC with a USB cable. The user should receive a prompt if the driver needs to be installed. If not, open Device Manager (Under “System” in Control Panel), find the device and select “Update Driver Software”.

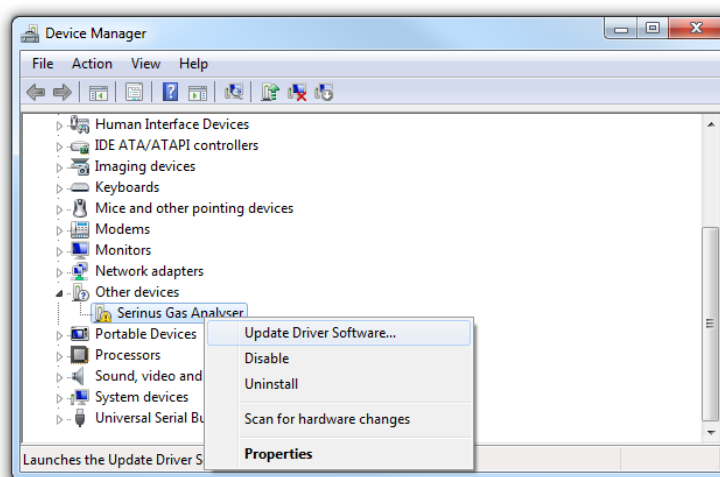

Figure 119 – Installing Driver Software (Device Manager)

2. When prompted where to search for the driver, select “**Browse my computer for driver software**”.

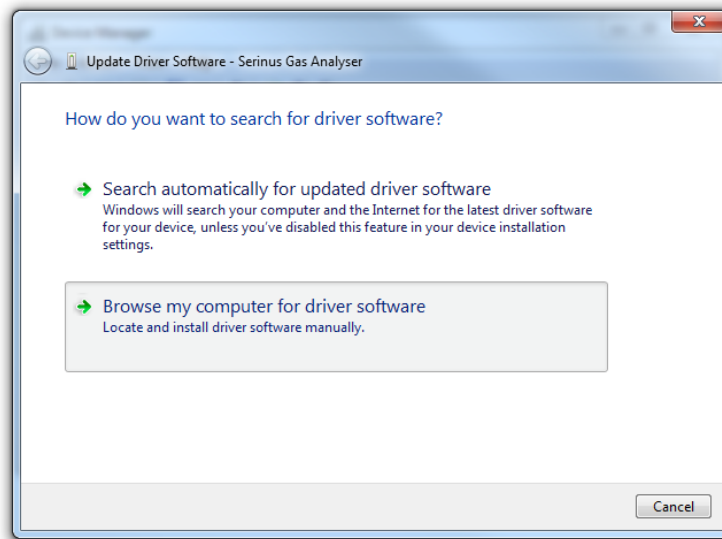

Figure 120 – Update Driver Popup

3. The Serinus USB driver is located on the green Ecotech resources USB stick under “\Drivers\Ecotech Analyser”. Select this directory and click **Next**.

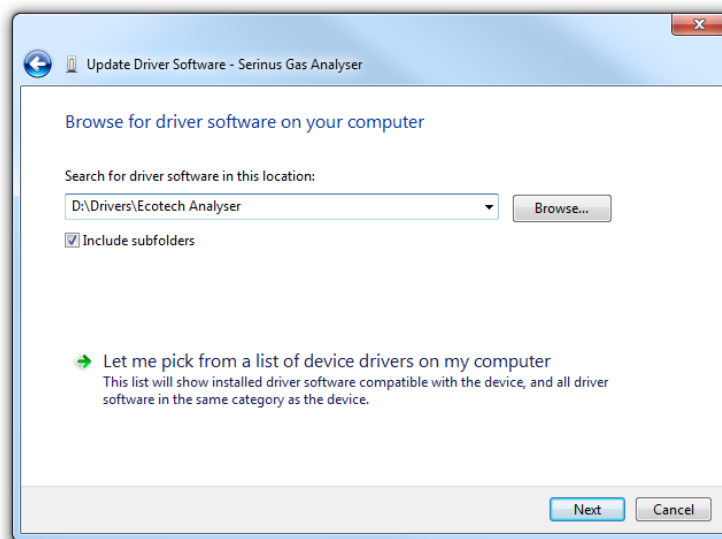

Figure 121 – Update Driver Popup (Directory Location)

4. If the user receives a confirmation prompt to install the driver, select **Install**.

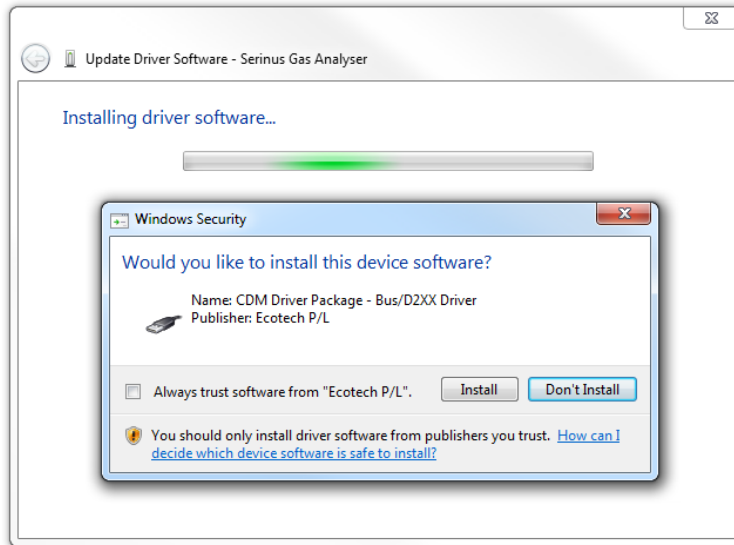

Figure 122 – Installing Driver Confirmation Prompt

5. If everything went smoothly, Windows will inform the user that the driver was successfully installed.

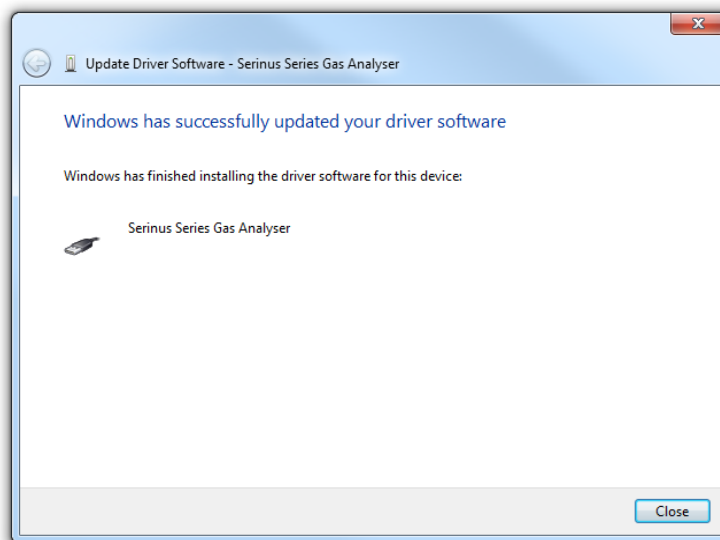

Figure 123 – Successful Driver Installation

4.7.1.2 Connecting over Serial (RS-232)

The following steps outline how to setup the instrument for connection to a PC or datalogger (refer to Section 3.5.38).

Procedure

1. Open - **Main Menu** → **Communication Menu** → **Serial Communication Menu**.
2. Determine which RS232 Port the user is physically making the connection with. Remember, multidrop is only supported on RS232 #2.
3. Select - **Baudrate** → 38400 - Accept (Set an appropriate baud rate, default is 38400).
4. Select - **Protocol** → **Advanced** - Accept.

If the user is running Airodis in a multidrop configuration, ensure that the **Serial ID** is unique for each instrument on the chain.

4.7.1.3 Connecting over Network (TCP/IP)

Refer to Section 4.3.2 to setup the instrument for connection to a PC or datalogger using a static IP address.

4.7.2 Installing Airodis

The user can download data from the instrument using either a full retail (paid) version of Airodis or with the demo version which is included on the green Product Resources USB Stick. The demo version has limited functionality, but will allow the user to download and export data from up to three instruments. If the user doesn't have Airodis Installed, they can obtain it from the following address:

<http://www.airodis.com.au>

The installer is straightforward: Ensure the user selects the correct version of software to install for their operating system. If they are running 64-bit windows, install the 64-bit (x64) version. Otherwise, install the 32-bit (x86) version.

4.7.3 Configuring Airodis

1. Once installed, double click on the Airodis shortcut on the desktop to start Airodis Workspace Manager. The user will be presented with the default workspace options. These will suffice for downloading data from the instrument.

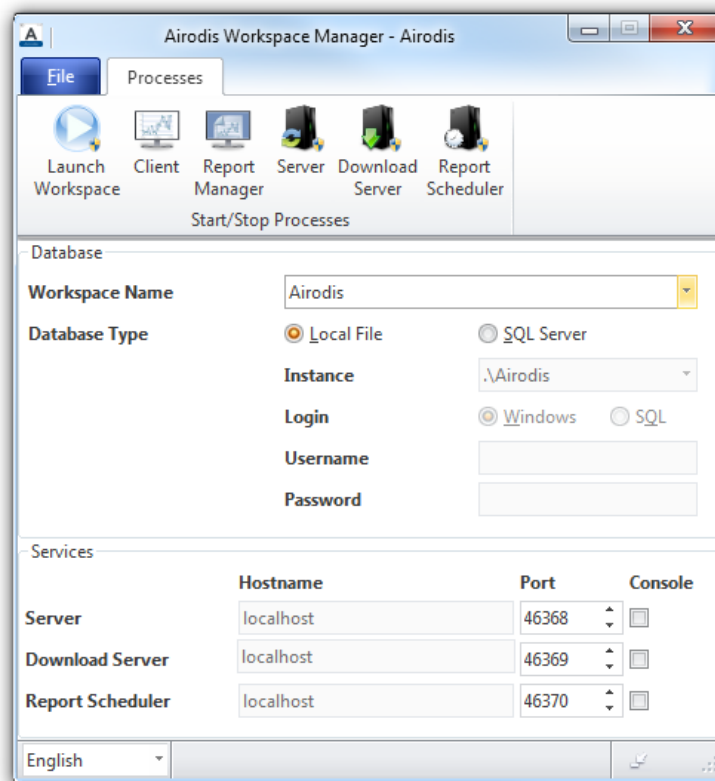

Figure 124 – Airodis Workspace Manager

2. Start the Client, Server and Download Server by single-clicking the toggle button for each. The client may prompt to register with Acoem or install an update. Follow the prompts if it does.

3. Once the Client application has loaded, click **Home**→**Add Station**→**New Physical Station**.

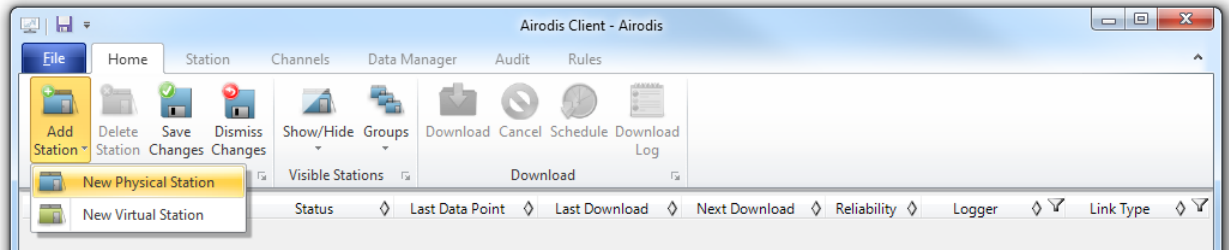

Figure 125 – Adding a New Station

4. This automatically brings the user to the **Station** tab on the ribbon. Enter the communication details to connect to the instrument.

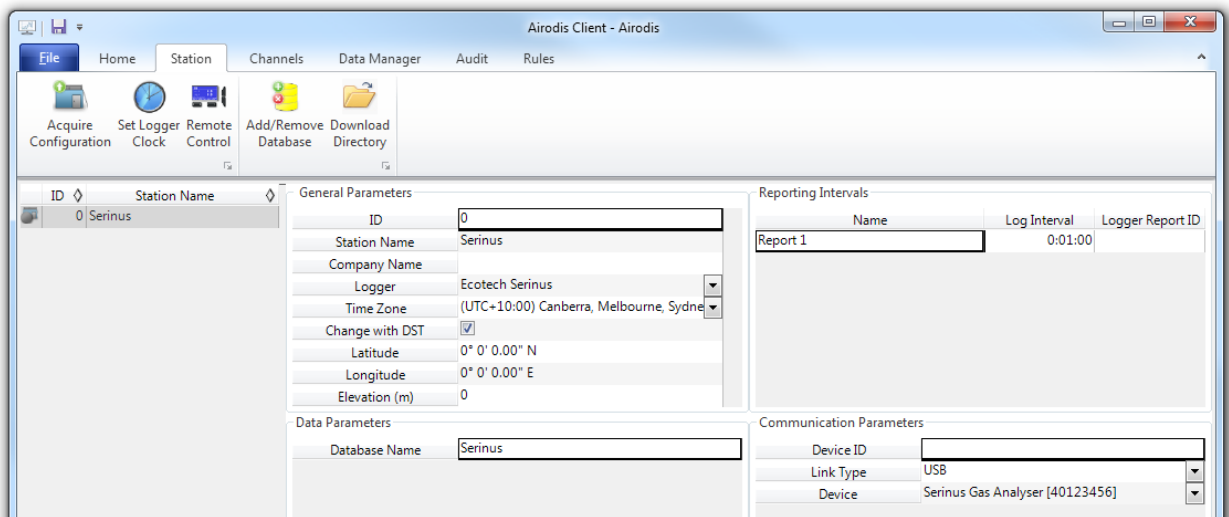

Figure 126 – New Station Connection

Table 5 – Setting up a New Station via Airodis

Property	Description
Station Name	The name of the station. If the user has other loggers, the name is used to distinguish them.
Logger	Set this to “Acoem Serinus” when downloading from any Serinus series instrument. This will communicate with the instrument via the Advanced protocol. If using a network or serial connection, ensure that the Advanced protocol has also been selected on the instrument itself.
Time Zone	Set this to the time zone that the instrument is located in.
DST	Enable this option if the user plan on changing the clock on the instrument with daylight savings. Leave this disabled if the clock does not shift during DST. The instrument will need to be adjusted manually for DST - it will not happen automatically.
Database Name	This is the name to be used for the table in the SQL database containing this station’s data. It must be unique for each station.

Property	Description
Device ID	Enter the Serial ID of the instrument. If the user is not using multidrop; this can be set to "0" or left blank.
Link Type	Select the type of connection used to connect to the instrument. Different properties will appear depending on the link type selected. Align these settings with those of the instrument.
Log Interval	This needs to be the same as the Data Log Interval setting on the instrument.

Note: The available fields for communication parameters will change when the user change the link type. The user will need to set the communication parameters that have been defined on the instrument.

- Once the station has been created, save the station by clicking the Save shortcut icon or **File**→**Save**.
- Click Acquire Configuration. This will probe the Serinus for a channel list. After a few seconds, the channel list should be visible in the Channels tab.

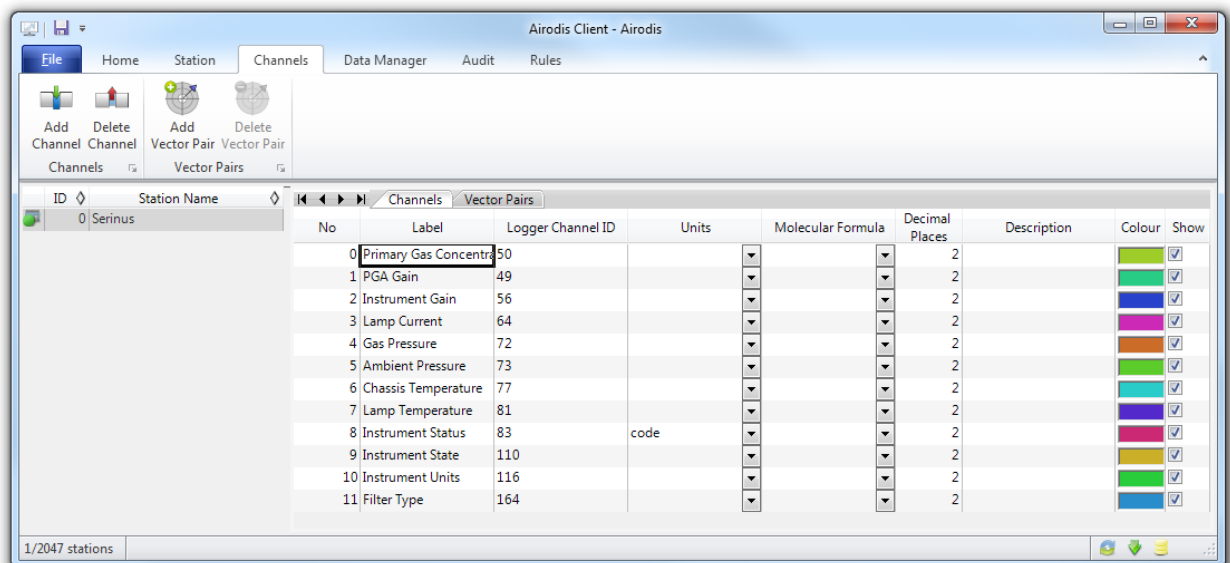

Figure 127 – Station Configuration (Channel List)

Note: If there was an error connecting to the instrument, a red dot will appear next to the station name in the station list (on the far left hand side). Hovering over the red dot will present the user with an error message (refer to Figure 128).

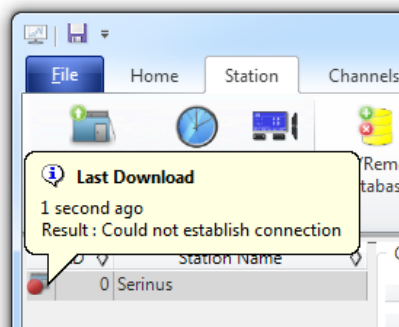

Figure 128 – Error Status Notification

7. Select the Data Manager tab, click download. The Download Data window will appear. Select the appropriate time period that the user wishes to download and click Download.

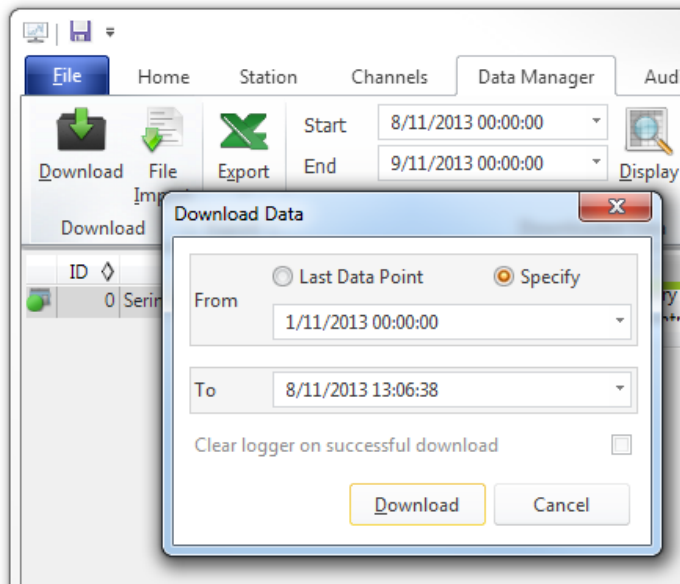

Figure 129 – Downloading Data

8. The status of the download will appear in the bottom-left corner of the window. The user can also monitor the status of the download from the Home tab.

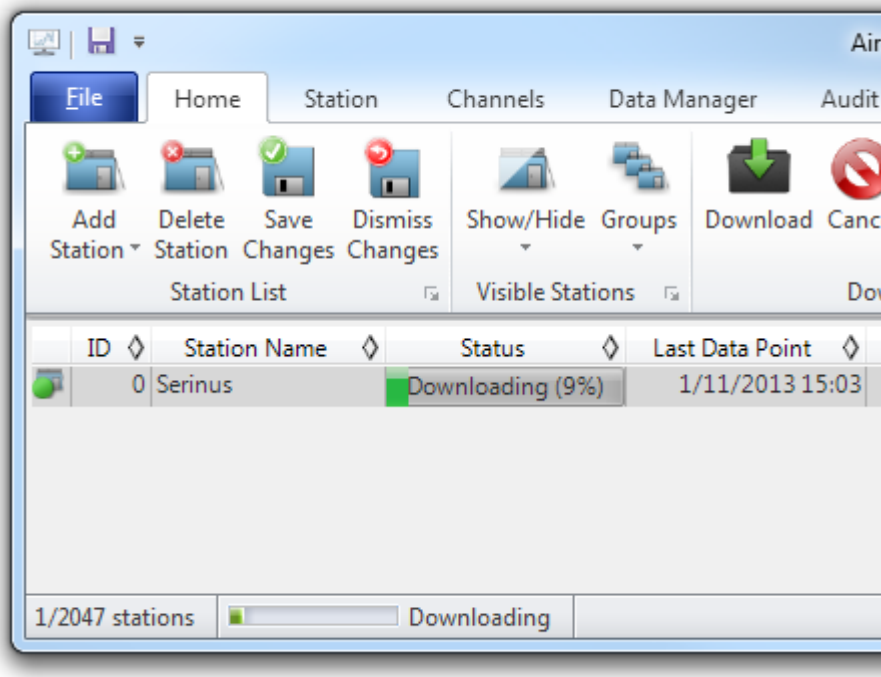

Figure 130 – Download Data Status

- Data will become available in the data manager as it is downloaded. The user can load data for a date range by entering the start and end dates and clicking Display. The selected data will be loaded into the data manager.

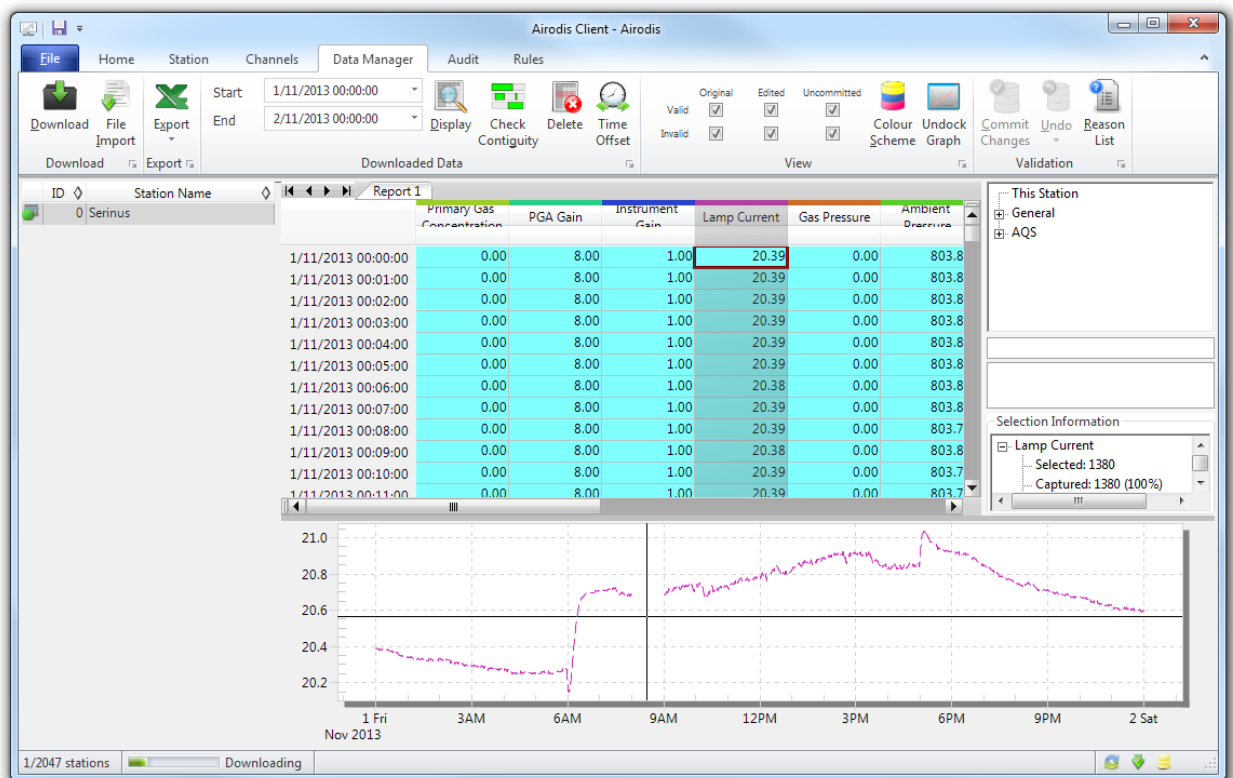

Figure 131 – Data Visibility

10. Data can be exported by clicking the Export function. This will allow the user to save his data in CSV format, which can be loaded into another program such as Microsoft Excel. It is also possible to copy/paste (Ctrl + C / Ctrl + V) data directly from the Airodis data manager.

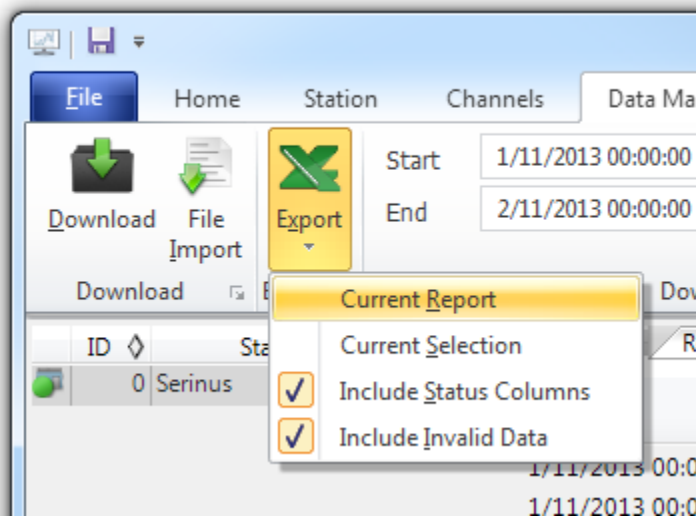

Figure 132 – Exporting Data

11. That's it! The data has been downloaded from the instrument and exported to a standard CSV file.

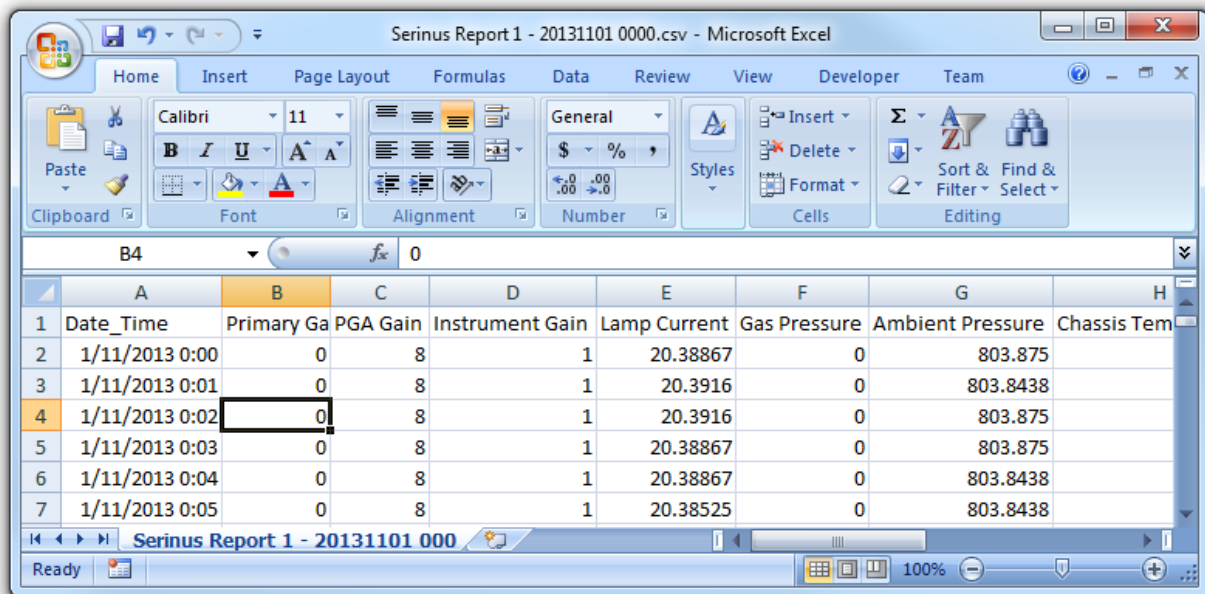

Figure 133 – Data Download Complete

4.8 Serinus Remote App/Bluetooth

The Serinus Remote Application allows for any Android device (Tablet or Smartphone) to connect to an instrument.

The Serinus Remote Application allows the user to:

- Completely control the instrument using a remote screen displayed on the device.

- Download logged data and take snapshots of all the instrument parameters.
- Construct graphs from logged data or real time measurements.

The following sections cover installation, connection and use of the application.

4.8.1 Installation

The Serinus Remote Application can be found in the Google Play Store by searching for Acoem or Serinus. Once found, choose to **Install** the application and **Open** to start the application.

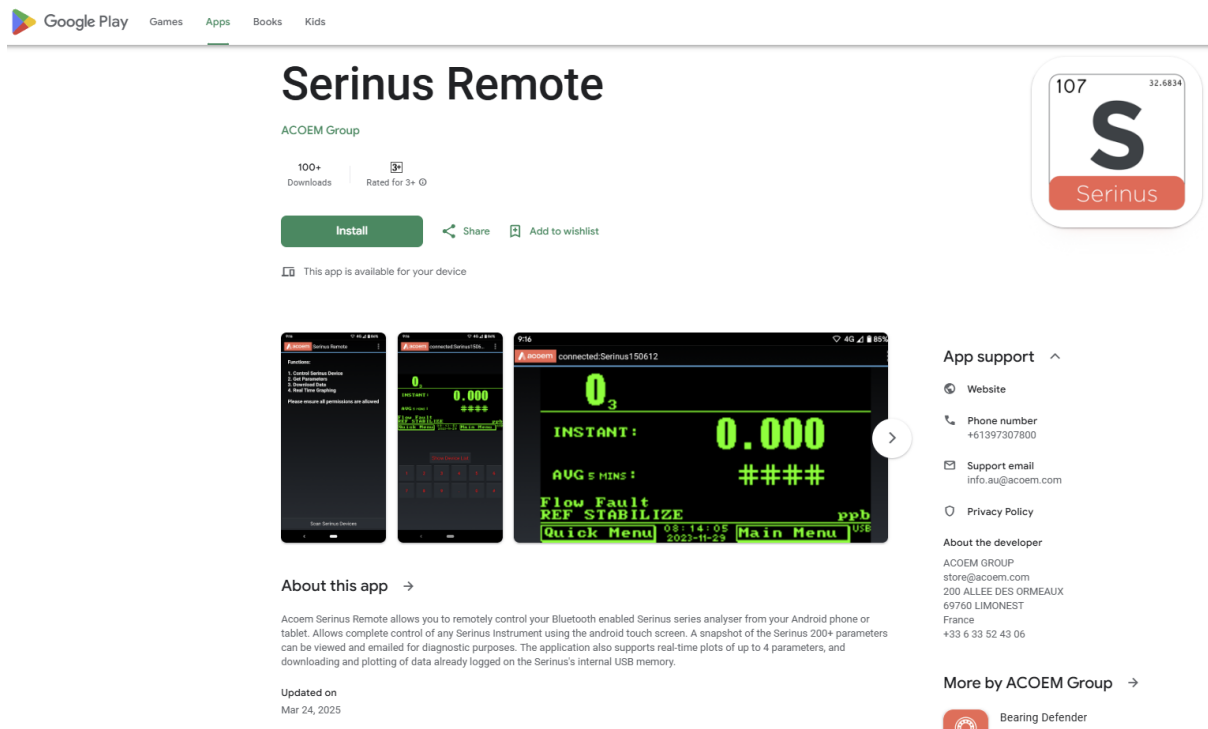

Figure 134 – Downloading the App from Google Play Store

Note: A menu containing additional features and functions can be accessed by entering the Options Menu (or similar) on your device. The location and format of this menu may vary.

4.8.2 Connecting to the Instrument

Procedure

1. Open - **Main Menu** → **Communications Menu** → **Bluetooth Menu** (to find the Bluetooth ID and PIN) (refer to Section 3.5.43).
2. Touch the Scan Serinus Analysers button at the bottom of the device screen.
3. Select the **Analyser ID** from either the **Paired Devices** or the **Other Available Devices**.
4. Input the PIN (if prompted) and press OK (refer to Section 3.5.43).

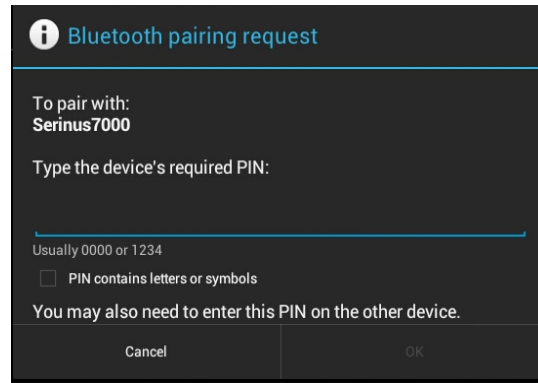

Figure 135 – Bluetooth Pairing Request

5. A screen shot of the instrument's current screen should appear on the user smartphone or tablet. To disconnect press the back key/button on the device.

Note: Once the instrument has been paired with the device it will appear under “Paired Devices” and the PIN will not need to be entered again. Only one Bluetooth connection can be made to an instrument at any one time.

4.8.3 Control Serinus Instrument

Once connected the user has full control of the instrument. The range for remote control depends on the device's Bluetooth capabilities and any intervening obstructions, but is usually up to 30 meters.

Remote Screen Operation

With the exception of the number pad, all button functions/actions can be performed by touching the screen. This includes the selection buttons and the scroll buttons. Touching any part of the screen where there is not already a button also enacts the functions of the scroll buttons.

Home Screen

Touching the upper half of the screen increases the contrast and touching the lower half of the screen decreases contrast on the real instrument.

Menus

Touching the upper or lower half of the screen allows the user to scroll up and down respectively.

Right-hand Section of the Screen

Swiping from right to left brings up the number pad for entering numbers (swipe from left to right to

hide the number pad).

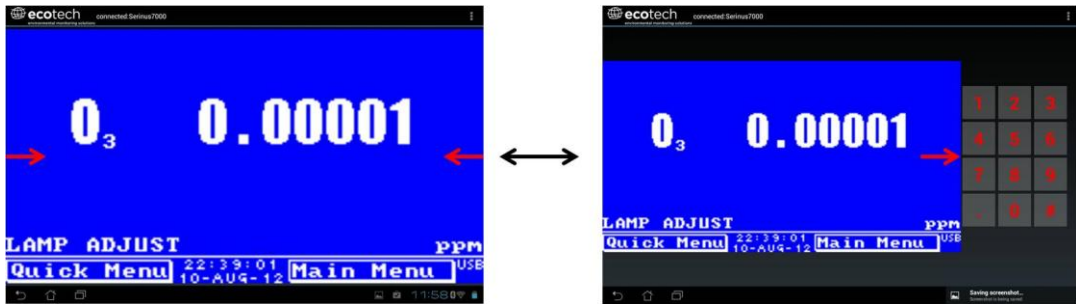

Figure 136 – Showing or Hiding the NumPad

Left-hand Section of the Screen

Swiping from left to right brings up a list of available analysers (swipe from right to left to hide the instrument list).

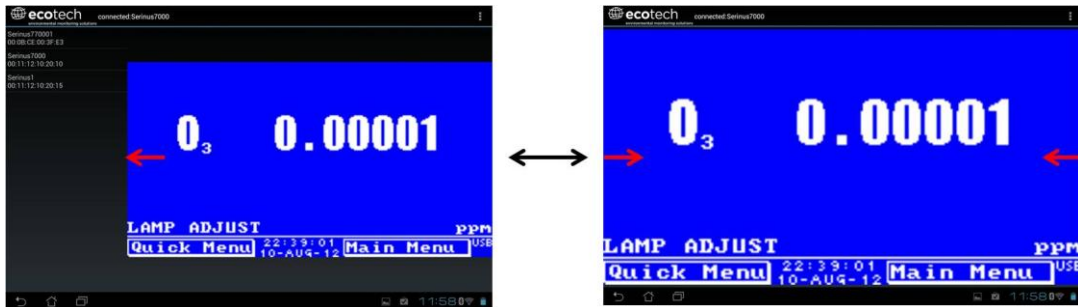

Figure 137 – Switching Analysis

Back Button

This button will enable the user to return to the selection screen, allowing them to connect to a different instrument.

Options Menu

The Options Menu is accessed by the grey button in the top right corner of the screen or pressing the Menu Button, depending on the user's Android device.

Table 6 – Options Menu

Refresh	Refresh the display.
Show/Hide NumPad	Show or hide the number pad.
Real Time Plot	Refer to Section 4.8.4.
Download	Refer to Section 4.8.5.
Get Parameters	Refer to Section 4.8.6.
Preferences	Refer to Section 4.8.7.

4.8.4 Real-Time Plot

Allows the user to view real-time plotting of up to four parameters at the same time. The user can also scroll from left to right, top to bottom or zoom in and out on the plot by swiping/pinching.

Once the plot is zoomed or scrolled, it enters into Observer Mode, meaning that auto-scaling is suspended. Press at the top of the screen (where it says Observer Mode) to return to Normal Mode.

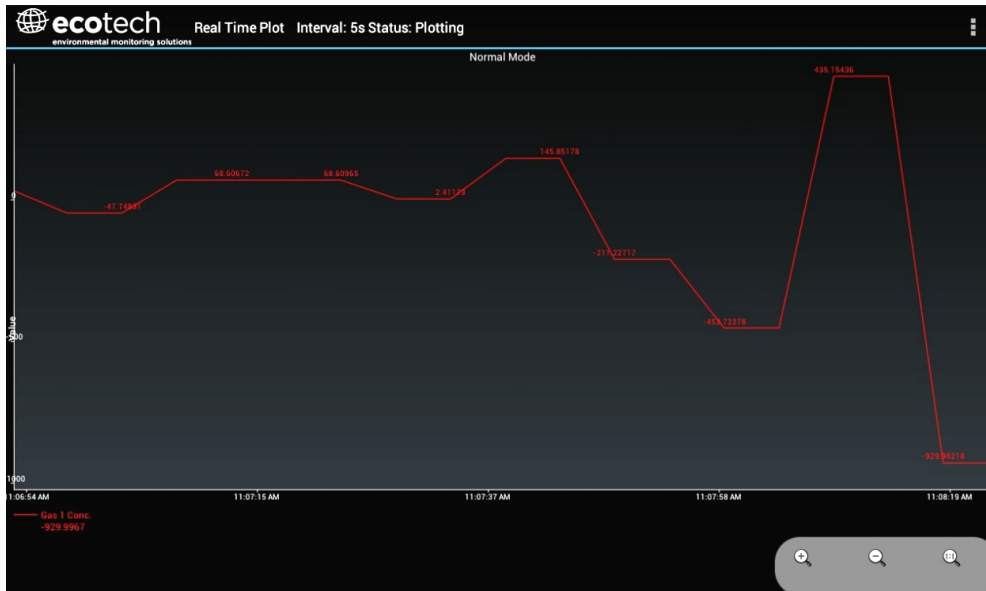

Figure 138 – Real-Time Plot

Options Menu

The Options Menu is accessed by the grey button in the top right corner of the screen or pressing the menu button, depending on the user’s Android device.

Start	Restarts graphing if it has been stopped and returns the graph to Normal Mode .
Stop	Stops collecting data. In this mode the user can scroll the display without going into Observer Mode , because the system has no data collection to suspend. It is necessary to “Stop” data collection to set the interval.
Clear	Clears the window and restarts the graphing.
Save	Saves an image of the graph and accompanying data in the location specified in preferences (refer to Section 4.8.7). The user will also be asked whether they want to send the file and data via email. When saving the data, the user can choose to Save All Data or Customise the length of the data by entering a time between five minutes and six hours. Only the data from the start of collection to that limit will be saved (although the plot will still appear exactly as it does on the screen).
Set Interval	While data collection is stopped, the user can specify the time intervals between collections.

4.8.5 Download

Download logged data from the USB memory stick inside the instrument. All data logged by the instrument to the USB memory stick over the period of time specified will be collected. Due to the slow connection speed of Bluetooth, this should only be used for relatively short sections of data. Downloading one days' worth of one minute data is likely to take a couple of minutes.

Options Menu

Save	Generates a filename based on the start and end date/time specified. It saves the downloaded data in the location specified in preferences and asks to send the saved comma separated text file (.csv) as an attachment to an email. This file format does not include the parameter headings, just the values.
Send E-Mail	Sends an email with the parameter data in the body of the email, formatted as displayed (this includes the parameter name and the values).
Plot	Graphs the data that has been downloaded. The user is prompted to select which parameters to plot based on the parameters that were being logged (refer to Figure 139).
Preferences	Refer to Section 4.8.7.

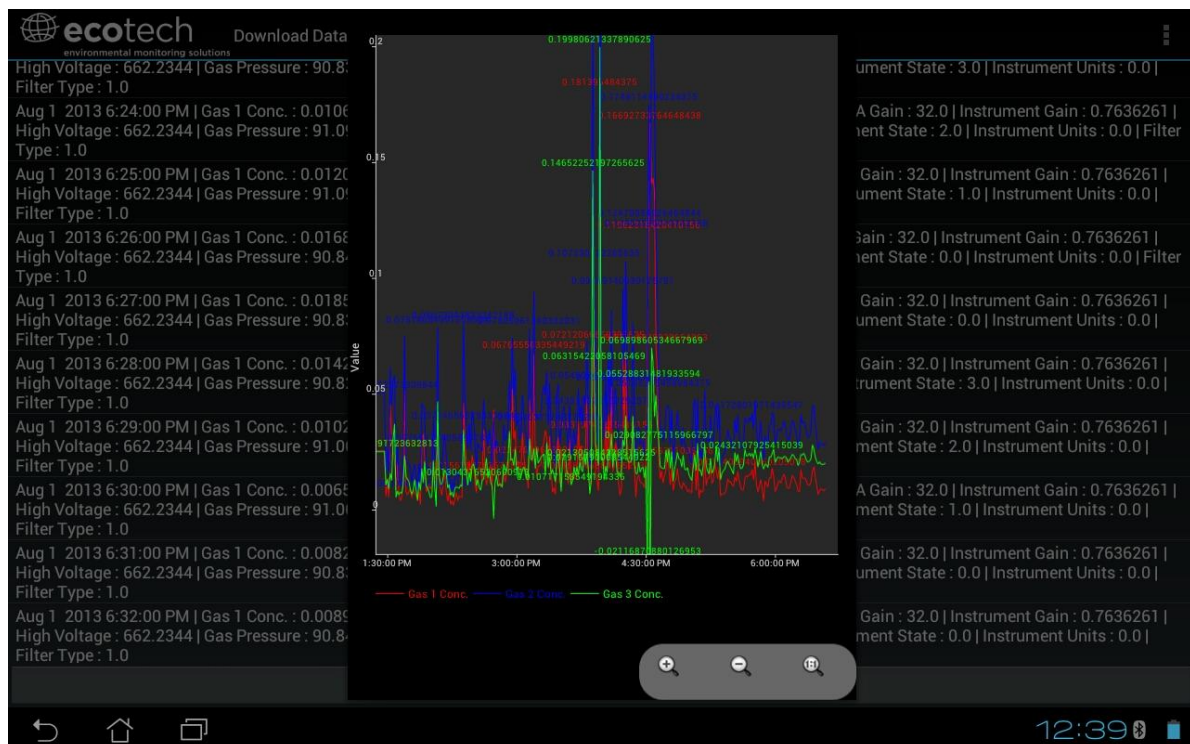

Figure 139 – Plot of Downloaded Data

4.8.6 Get Parameters

Download a list of parameters and corresponding values directly from the instrument. This list of parameters is a snap shot of the current instrument state and is very helpful in diagnosing any problems with the instrument.

Options Menu

Get Parameters	Refreshes the parameter list display.
Save	Generates a filename from the current date and time, saves the parameter data in the location specified in preferences, and then asks to send the saved text file as an attachment to an email.
Send E-Mail	Sends an email with the parameter data in the body of the email, formatted as displayed.
Preferences	Refer to Section 4.8.7.

4.8.7 Preferences

The Preferences Menu allows the operator to adjust the directory settings, logged data format and the colour scheme settings. It can be accessed through the Options Menu in most windows.

Directory Settings

The operator can specify/select where to save the parameter lists, logged data and real time plots.

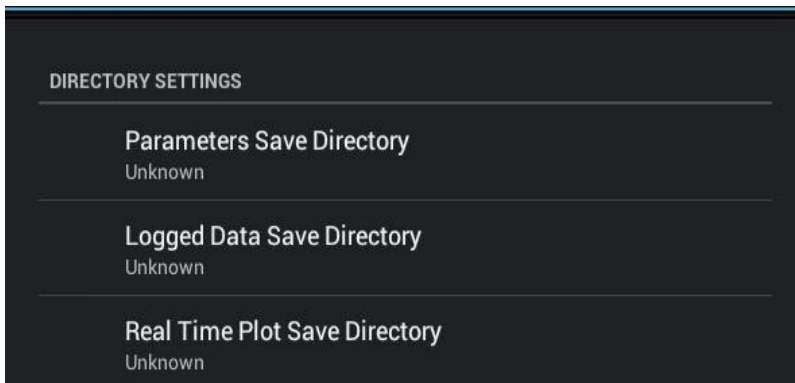

Figure 140 – Directory Settings

Logs Format

When downloading logged data, the parameters can be displayed on one line or each parameter on a separate line.

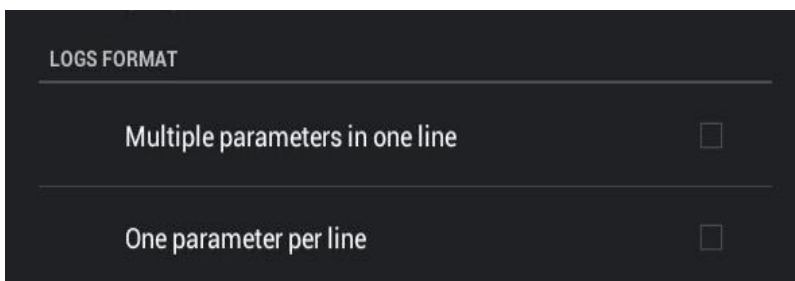

Figure 141 – Logs Format

Colour Theme Settings

Allows the user to choose a colour scheme for the remote screen, either Matrix, Classic, Emacs or Custom.

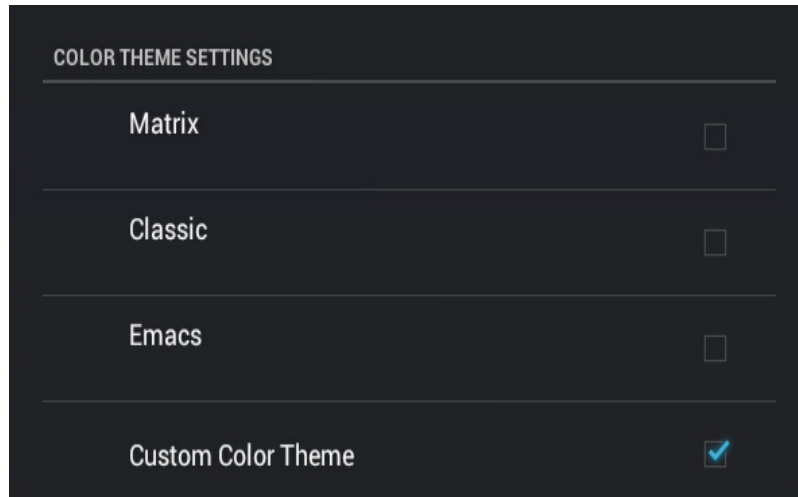

Figure 142 – Colour Theme Settings

This page is intentionally blank.

5. Calibration

The following sections will cover how to calibrate the MFC's, Ozone flow, pressure, Ozone generator and photometer.

5.1 MFC Calibration

Serinus Cal 1000, 2000 and 3000

It is necessary occasionally to re-calibrate the mass flow controllers within the Serinus Cal. This is required for all Serinus Cal models.

In order to perform this task, the user will require a flow device/s having an accuracy of equal to or better than 1% of the device under test and must be currently certified.

Equipment Required

- A certified mass flow measurement device **OR**
- A certified volumetric flow measurement device/s in conjunction with a certified temperature probe and barometer

Note: The measurement devices range must match the range of the Serinus Cal MFC the user is calibrating. Typical setup is a Diluent MFC Range 0 - 10 slpm and a Source Gas MFC Range 0 - 50 sccm.

Procedure

Note: The user can either, connect another MFM (Mass Flow Meter) device to the Serinus Cal set to 0 Deg C and 1013.25 mbar, **OR** if the measurement device is volumetric, measure the temperature and pressure of the gas stream to calculate the volumetric flow into mass flow. It is important to have stable ambient conditions when performing this calibration to ensure accurate and consistent results.



CAUTION

It is recommended that exhaust air is not expelled into a shelter/room inhabited by people. It should be expelled into the external air and away from the sample inlet. Connecting diluent AIR to a span port (via a T-Piece) reduces the risk of exposure to hazardous source gases.

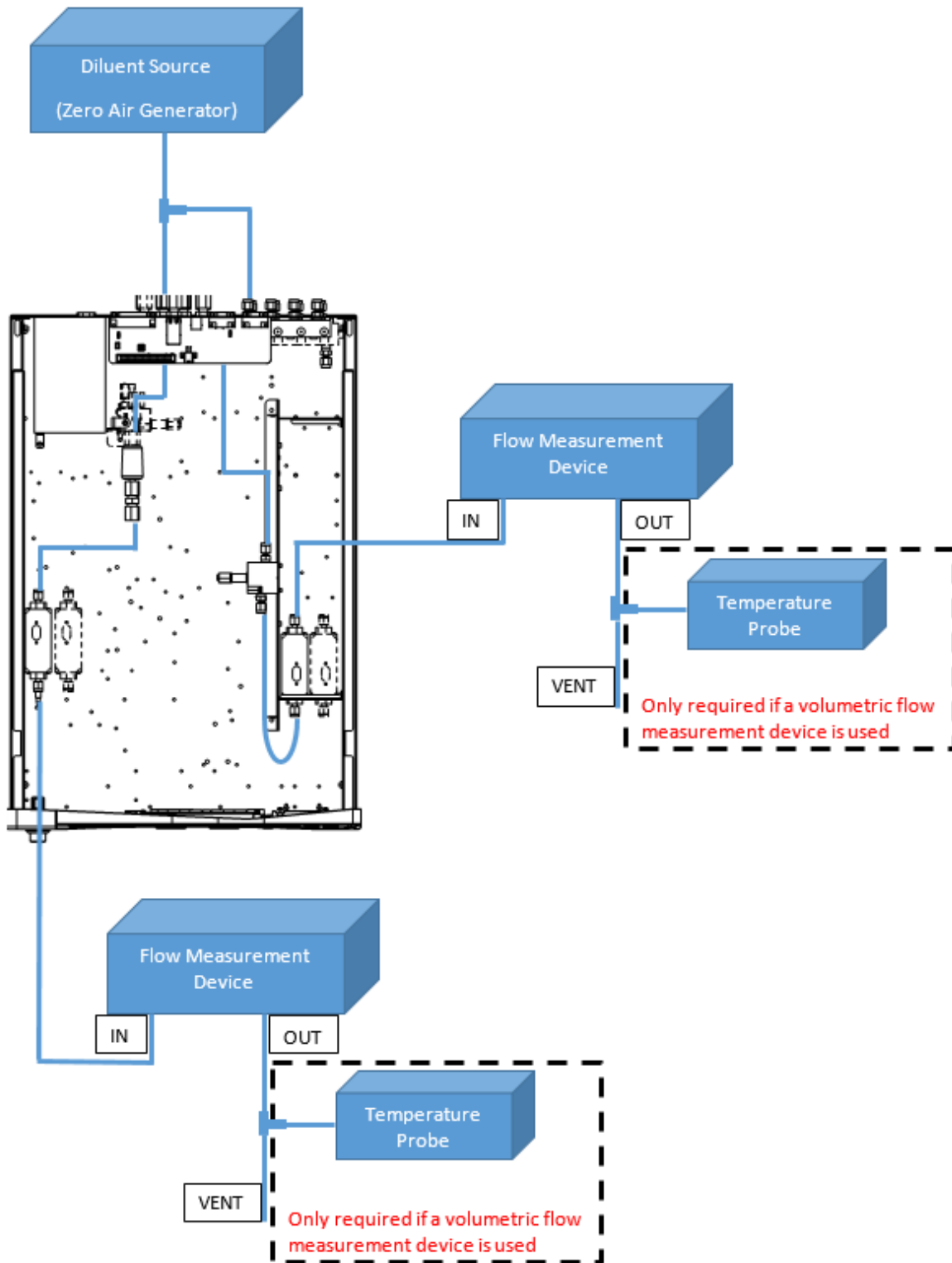

Figure 143 – MFC Calibration Setup

Procedure

5.1.1 MFC Pre Calibration Setup

1. Backup settings and parameters to the internal USB memory stick. (Refer to Section 7.3)
2. MFC zero flow voltage check and adjustment (Refer to Section 6.4.4).

3. Connect diluent air to the **diluent port** as well as a spare **source port** (via a T-piece as shown in Figure 143).

5.1.2 MFC Calibration

Before starting this procedure complete the MFC pre calibration setup (refer to Section 5.1.1). If at any point during calibration the user makes a mistake or wishes to abort, press cancel to prevent any changes.

1. Open - **Main Menu** → **Calibration Menu** → **MFC Calibration Menu**.
2. Select - **Standard Temperature** - (select the standard temperature required for your region) - Accept.
3. Select - **Gas - AIR** - Accept.
4. Select - **MFC** - (select the MFC the user wishes to calibrate) - Accept.
5. Edit - **Diluent Port** - (select 1 or 2 depending on the port the user connected the AIR to) - Accept.
6. Edit - **Source Port** - (select 1 to 8 depending on the port the user connected the AIR to) - Accept.
7. Confirm your test measurement device is within the correct range of the MFC under calibration.
8. Remove the top cover of the Serinus Cal.
9. Connect the flow measurement device directly to the output port of the MFC (refer to Figure 143).
10. Lightly place the top cover of the Serinus Cal (over the tubing connection to MFC ensuring not to crush or restrict the tubing) to ensure a stable temperature.
11. Edit - **Points** - (default is 10, but the user can have from 5 to 10 calibration points) - Accept.
12. Start - **MFC Calibration** - (follow the instructions, editing the displayed value to match your flow measurement device before accepting to start the next calibration point. Be sure to allow suitable stabilisation time, between points).

Note: If the user is using a volumetric flow measuring device, they need to correct the reading for temperature and pressure before entering the final value into the Serinus Cal.

13. MFC Calibration is now complete. Remove the tubing connected to the MFC and replace the cover.

5.1.3 Readout Calibration

Before starting this procedure complete the MFC pre calibration setup (refer to Section 5.1.1).

1. Open - **Main Menu** → **Calibration Menu** → **MFC Calibration Menu**.
2. Select - **Standard Temperature** - (select the valid standard temperature for your region) - Accept.
3. Select - **Gas - AIR** - Accept.
4. Select - **MFC** - (select the MFC the user wishes to calibrate) - Accept.
5. Edit - **Diluent Port** - (select 1 or 2 depending on the port the user connected the AIR to) - Accept.
6. Edit - **Source Port** - (select 1 to 8 depending on the port the user connected the AIR to) - Accept.
7. Edit - **Points** - (default is 10, but the user can have from 5 to 10 calibration points) - Accept.
8. Start - Readout Calibration - (allow the instrument to run 10 seconds each step, maximum 1min 10 seconds).



CAUTION

The Serinus Cal MFC Readout Calibration will not work without a suitable diluent source connected to the instruments diluent port.

5.2 Ozone Flow Calibration

Serinus Cal 2000 and 3000

It may be necessary occasionally to adjust the pressure regulator supplying diluent air to the Ozone Generator.

Equipment required

- A certified mass flow measurement device or a certified volumetric flow measurement device (corrected for temperature and pressure) able to measure from 0 - 200 sccm range.

If the volumetric flow device is programmable set flow settings to 0 Deg and 1013.25 mbar to standardise and match the Serinus Cal.

If it is not programmable the user will also need a certified temperature probe and a pressure sensor to correct measurement readings to 0 Deg STP and 1013.25 mbar.

Procedure

1. Supply between 120 kPa - 180 kPa of pressurised zero air to diluent port.
2. Remove the top cover of the Serinus Cal.
3. Disconnect the tubing connected to port **G** on the mixing manifold and connect your flow measurement device.

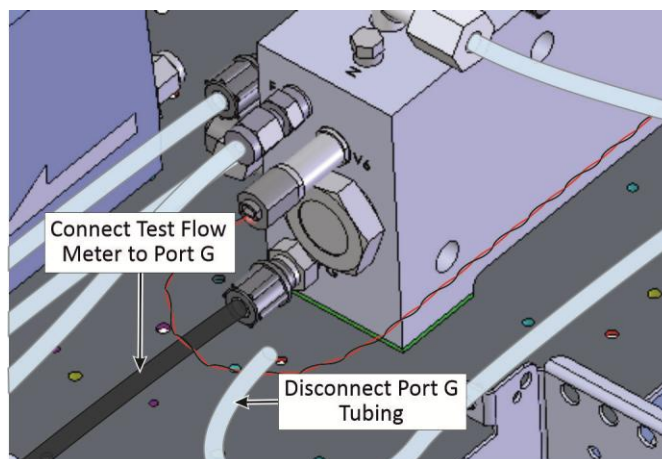

Figure 144 – Port G: Test Flow Meter Shown Connected

4. The calibration procedure consists of two flow points one at 80 sccm and 100 sccm.
5. Open - **Main Menu** → **Calibration Menu** → **Pressure Calibration Menu** - (read note) - OK.

Note: This action will place the valve sequencing on hold; normal sampling will be interrupted.

6. Start - **O3 Flow** - (Follow the instructions, Adjust the pressure regulator (turning the knob left or right to adjust flow) inside the Serinus Cal until 80 ± 5 sccm is measured on your flow device).

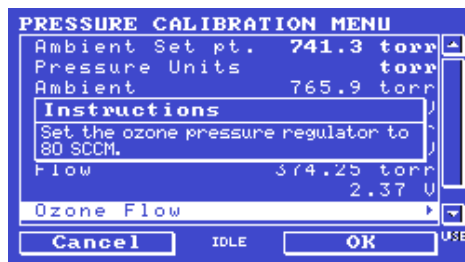

Figure 145 – Ozone Flow Calibration 80 sccm

7. Press **OK** to lock in the calibration point and receive the next set of instructions.

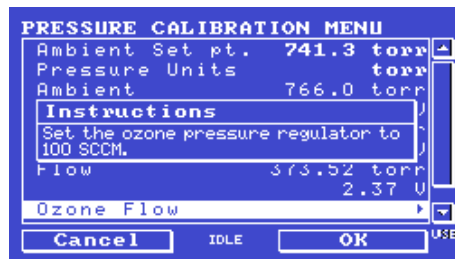

Figure 146 – Ozone Flow Calibration 100 sccm

8. Adjust the pressure regulator until 100 ± 5 sccm is measured on your flow device.
9. Press **OK** to lock in the second calibration point.
10. Disconnect flow meter and reconnect tubing to port **G**.
11. Replace the top lid.
12. Ozone flow calibration complete.

5.3 Pressure Calibration

Serinus Cal 3000

The pressure sensors are a vital component of the instrument operation and the pressure calibration should be checked on installation or whenever maintenance is performed.

A thorough leak check must be performed prior to performing a pressure calibration (refer to Section 6.4.1).

The pressure calibration can either be a two point calibration (one point under vacuum and the other at ambient pressure) or a single ambient point calibration when very minor adjustments are required.

Note: Ensure that the instrument has been running for at least one hour before any calibration is performed to ensure the instrument's stability. When performing a two point pressure calibration, it is advisable to perform the vacuum pressure calibration first.

5.3.1 Full Pressure Calibration (Two Point Calibration)

This section outlines how to perform a full pressure calibration. Using the required equipment follow the steps below to complete a full pressure calibration.

Note: Ensure that the instrument has been running for at least one hour before the calibration is performed.

Note: Ensure units of measure are the same on both the barometer and instrument.

Equipment Required

- Barometer

Procedure

1. Open - **Main Menu** → **Calibration Menu** → **Pressure Calibration Menu** - (read note) - OK.

Note: This action will place the valve sequencing on hold; normal sampling will be interrupted.

2. Edit - **Vacuum Set Pt.** - (Read displayed instructions)) - OK.
3. Disconnect the inlet of the Photometer as shown in Figure 147.

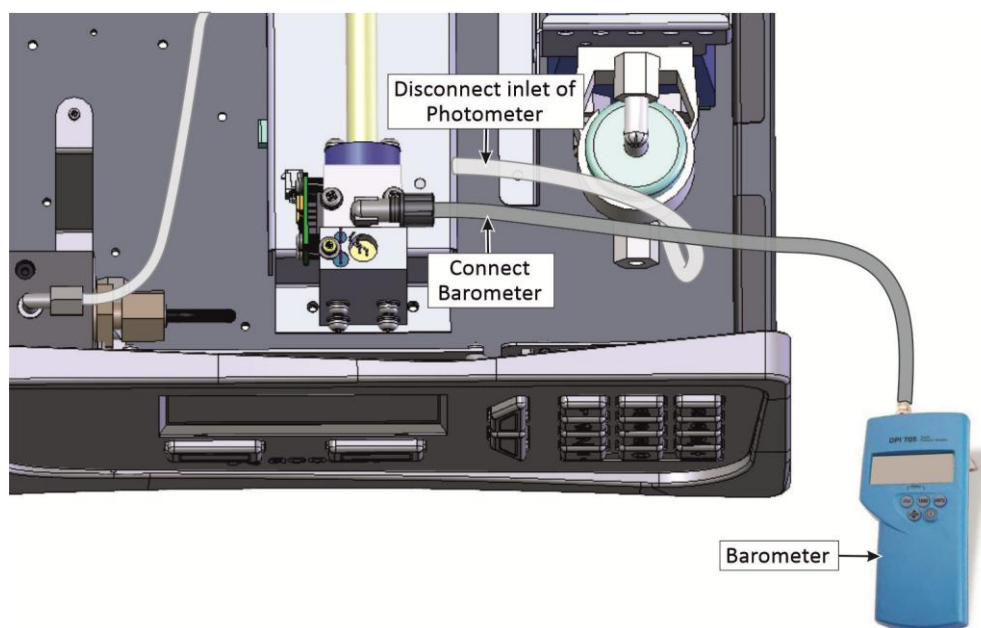

Figure 147 – Disconnect inlet of Photometer

4. Refer to Figure 147. Now connect the barometer to the outlet of the Photometer.

Note: Ensure units of measure are the same on both the barometer and instrument.

5. Wait 2 - 5 minutes and ensure the pressure reading on the barometer has dropped and is stable.
6. Enter the barometer reading into the instrument - Accept.
7. Read displayed instructions - OK.
8. Disconnect the barometer from the outlet.
9. Wait 2 - 5 min, enter the ambient barometer reading into the instrument - Accept.
10. Read displayed instructions - OK. Pressure calibration is now complete, reconnect the photometer outlet tube.

Note: Both of the pressure sensors should now be displaying the current ambient pressure and they should be the same value within 3 torr of each other.

11. Back - **Pressure Calibration Menu** - (read note) - OK.

5.3.2 Pressure Calibration (Ambient Only)

Full pressure calibrations are generally recommended; however, it is possible to calibrate only the ambient point in cases where only a minor ambient pressure adjustment is required.

Note: Ensure that the instrument has been running for at least one hour before the calibration is performed.

Note: Ensure units of measure are the same on both the barometer and instrument.

Equipment Required

- Barometer

Procedure

1. Open - **Main Menu** → **Calibration Menu** → **Pressure Calibration Menu** - (read note) - OK.

Note: This action will place the valve sequencing on hold; normal sampling will be interrupted.

2. Edit - **Ambient Set Pt.** - (Read displayed instructions) - OK.
3. Disconnect the outlet of the Photometer.
4. Wait 2 - 5 min and enter the ambient barometer reading into the instrument - Accept.
5. Read displayed instructions - OK. Pressure calibration is now complete, reconnect the photometer inlet tube.

Note: Both of the pressure sensors should now be displaying the current ambient pressure and they should be the same value within 3 torr of each other.

6. Back - **Pressure Calibration Menu** - (read note) - OK.

5.4 Ozone Generator Characterisation - Serinus Cal 2000

It may be necessary occasionally to adjust the Ozone output characterisation on the Serinus Cal 2000. This is typically performed after the Ozone generator UV lamp has been replaced or if the Ozone output has significantly drifted away from requested set point.

Equipment Required

- (AIR) Diluent
- External Ozone measurement device

Procedure

1. Open - **Main Menu** → **Gas Supply Menu**.

2. Select - **Diluent Port 1** - AIR.
3. Physically connect a source of diluent air to the diluent port.



Figure 148 – Connect a Source of Diluent Air

4. Connect the one of the output ports to an external Ozone measurement device.

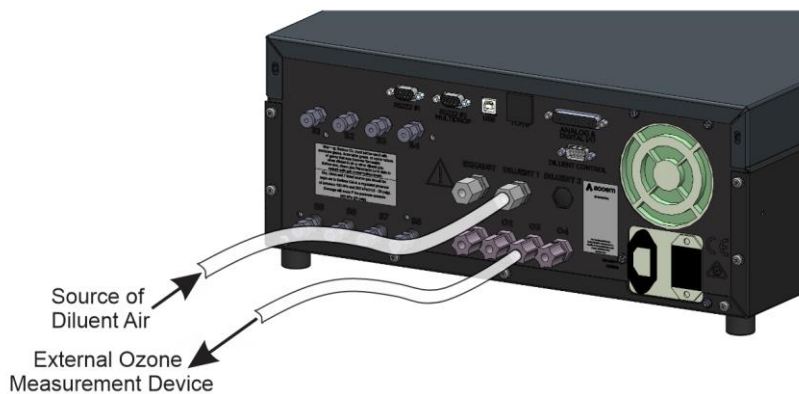

Figure 149 – Connect to External Ozone Measurement Device

5. Open - **Main Menu** → **Calibration Menu** → **Ozone Calibration Menu**.
6. Edit - **Flow** - (Enter the flow the user want the calibration to be performed at) - Accept.
7. Start - **Ozone Calibration** - (Wait until the external measurement device has a stable reading, enter that reading into the Serinus Cal.) - Accept.
8. Repeat for each of the ten steps of the calibration process.

Note: Selecting Cancel will terminate the calibration process without making any changes.

5.5 Ozone Generator Characterisation - Serinus Cal 3000

It may be necessary occasionally to adjust the Ozone output characterisation on the Serinus Cal 3000. This is typically performed after the Ozone generator UV lamp has been replaced or if the Ozone output has significantly drifted away from requested set point.

Note: This process will take at least 25 min and may take up to 5 hours.

Equipment Required

- (AIR) Diluent

Procedure

1. Open - **Main Menu** → **Gas Supply Menu**.
2. Select - **Diluent Port 1 - AIR** - Accept.
3. Physically connect a source of diluent air to the diluent port.



Figure 150 – Connect a Source of Diluent Air

4. Open - **Main Menu** → **Calibration Menu** → **Ozone Calibration Menu**.
5. Edit - **Flow** - (Enter the flow the user want the calibration to be performed at) - Accept.
6. Edit - **Min Range** - (Enter the value for the lowest calibration point to be used when running the automated Ozone calibration (run over 10 points spread between max and min)) - Accept.
7. Edit - **Max Range** - (Enter the value for the highest calibration point to be used when running the automated Ozone calibration (run over 10 points spread between max and min)) - Accept.
8. Start - **Ozone Calibration** - (The firmware will now automatically step up through 10 points and adjust itself based on the internal photometer results).
9. The process is complete when no steps are displayed and the “Start” button option returns.

Note: Pressing Stop or terminating the O3 Gen/Photometer point will terminate the calibration without saving any changes.

5.6 Photometer Calibration - Serinus Cal 3000

5.6.1 Photometer Pre Check

Note: Both your Serinus Cal 3000 and the external transfer standard should be powered up and active for a minimum of 2 hours.

Equipment required

- External Ozone transfer standard
- (AIR) Diluent

Procedure

1. Open - **Main Menu** → **Gas Supply Menu**.
2. Select - **Diluent Port 1 - AIR** - Accept.
3. Physically connect a source of diluent air to the diluent port.



Figure 151 – Connect a Source of Diluent Air

4. Connect an external Ozone transfer standard to one of the ports on the output manifold (if the external Ozone transfer standard requires external reference air ensure it is connected to the same diluent air source used by the Serinus Cal 3000).

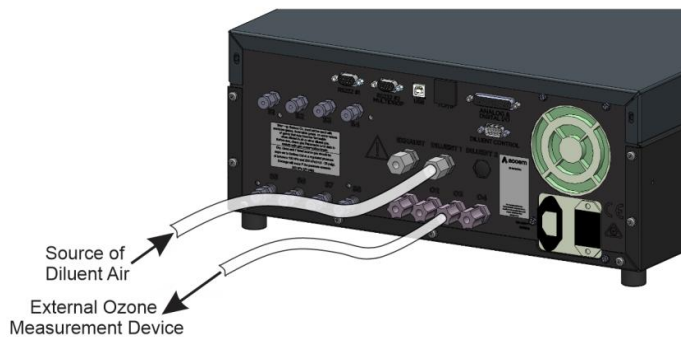

Figure 152 – Connect to External Ozone Transfer Standard

5. Create and run an **O3 Gen/Photometer** point at 100 % of range (normally 500 or 1000 ppb). Refer Section 3.2.2.6.
6. If the Ozone measured on the Serinus Cal 3000 is outside ± 2 % of the transfer standard then an adjustment will need to be made.

5.6.2 Photometer Calibration

Note: Both your Serinus Cal 3000 and the external transfer standard should be powered up and active for a minimum of 2 hours.

Equipment required

- External Ozone transfer standard
- (AIR) Diluent

Procedure

1. Open - **Main Menu** → **Gas Supply Menu**.
2. Select - **Diluent Port 1** - AIR.
3. Physically connect a source of diluent air to the diluent port.



Figure 153 – Connect a Source of Diluent Air

4. Connect an external Ozone transfer standard to one of the ports on the output manifold (if the external Ozone transfer standard requires external reference air ensure it is connected to the same diluent air source used by the Serinus Cal 3000).

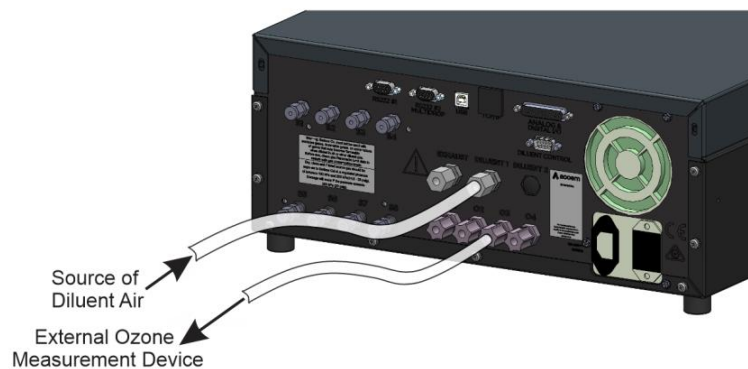

Figure 154 – Connect to External Ozone Transfer Standard

5. Create and run **O3 Gen/Photometer** point at 100 % of range (normally 500 or 1000 ppb) refer to Section 3.2.2.6.
6. Open - **Main Menu** → **Calibration Menu**.
7. Let the instrument stabilise, minimum 60 minutes.
8. Enter - **Span Calibrate O3** - (Enter the reading from the transfer standard) - Accept.

5.7 Photometer Audit With External Ozone Source

Note: Both your Serinus Cal 3000 and the external O3 transfer standard should be powered up and active for a minimum of 2 hours.

Equipment required

- External Ozone generator transfer standard
- (AIR) Diluent
- ¼" Kynar plugs

Procedure

1. Open - **Main Menu** → **Gas Supply Menu**.

2. Select - **Diluent Port 1 - AIR** - Accept.
3. Physically connect a source of diluent air to the diluent port.



Figure 155 – Connect a Source of Diluent Air

4. Return to the **Home Screen** (the user can press the bottom status light (green)).
5. Open - **Main Menu** → **Manual Operation Menu** → **Manual Point Menu**.
6. Select - **Operation - O3 Gen/Photometer** - Accept.
7. On - **Audit Mode** - On - (read message) - Ok.
8. Select - **Mode** - Point - Accept - Manual - Accept.
9. The manual point is now configured correctly and can be started automatically (via serial commands or digital bits) or manually (via the **Quick Menu**).
10. Select - **Mode** - Point - Accept - Manual - Accept.
11. Return to the **Home Screen** (the user can press the bottom status light (green)).
12. Connect an external Ozone generator transfer standard to port “O4” on the output manifold (if the external Ozone generator transfer standard requires external reference air ensure it is connected to the same diluent air source used by the Serinus Cal 3000).

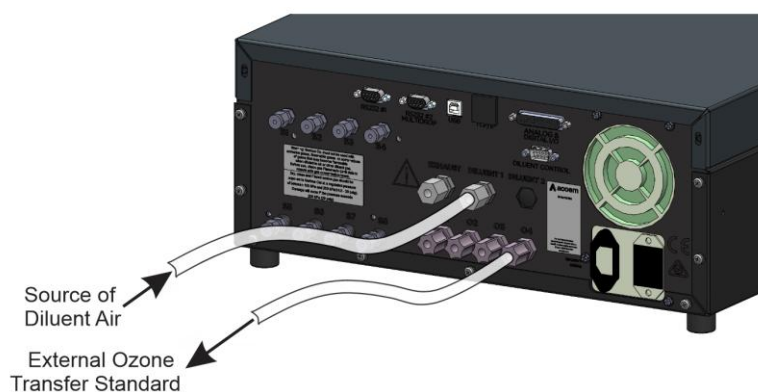

Figure 156 – Connect to External Ozone Transfer Standard

13. Block ports “O3” and “O2” on the output manifold. The last output “O1” becomes the vent for the excess Ozone generated from the external Ozone generator transfer standard.

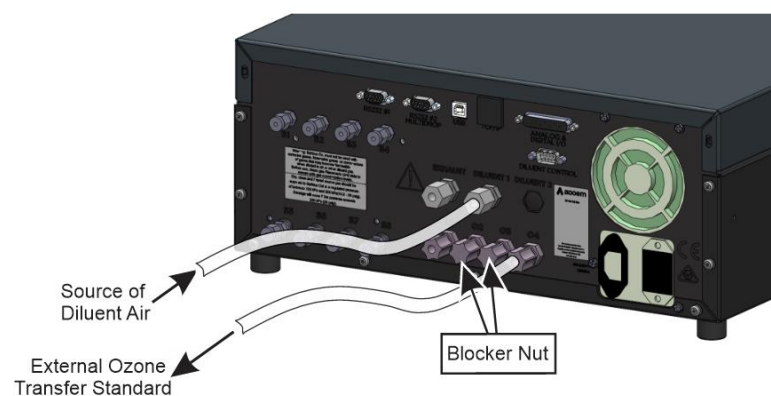

Figure 157 – Block Port ‘O3’ and O2’

14. Generate one litre @ 500 or 1000 ppb of Ozone and allow the instrument to stabilise, minimum 60 minutes.
15. Compare the external Ozone generator transfer standard against the Ozone concentration displayed on the home screen.

This page is intentionally blank.

6. Service

6.1 Additional Safety Requirements for Service Personnel

In addition to Safety Information stated previously, service personnel are also advised of the following:

- Documentation must be consulted in all cases where caution symbol is marked, in order to find out the nature of the potential hazards and any actions which have to be taken to avoid them. Refer to Table 1– Internationally Recognised Symbols.
- Do not energise the instrument until all conductive cleaning liquids, used on internal components, are dried up
- Do not replace the detachable mains supply cord with an inadequately rated cord. Any mains supply cord that is used with the instrument must comply with the safety requirements (250 V/10 A minimum requirement).

6.2 Maintenance Tools

To perform general maintenance on the Serinus Cal the user may require the following equipment:

- Customizable Test Equipment Case PN: H070301
- Digital Multimeter & Leads (DMM) PN: E031081 & E031082
- Barometer PN: E031080
- Thermometer & Probe PN: E031078 & E031079
- Flow Meter (Select Range)
 - o Range: 50 sccm to 5000 sccm PN: ZBI-200-220M
 - o Range: 300 sccm to 30000 sccm PN: ZBI-200-220H
- Minifit Extraction Tool PN: T030001
- Orifice Removal Tool PN: H010046
- Leak Test Jig PN: H050069
- Computer/Laptop and Connection Cable For Diagnostic Tests
- Assortment of 1/4" and 1/8" Tubing and Fittings.
- General Hand Tools



Figure 158 – Minifit Extraction Tool - (PN: T030001)



Figure 159 – Orifice/Sintered Filter Removal Tool - (PN: H010046)



Figure 160 – Leak Test Jig - (PN: H050069)



Figure 161 – Air Monitoring Test Equipment Kit (AMTEK) - Customisable

6.3 Maintenance Schedule

The Serinus Cal requires minimal ongoing maintenance. The intervals for calibration are determined by compliance standards that vary in different countries. The following is recommended by Acoem as a guide and compliance with local regulatory or international standards is the responsibility of the user.

Table 7 – Maintenance Schedule

Frequency	Maintenance Tasks
Monthly	

Frequency	Maintenance Tasks
Serinus Cal 1000, 2000, 3000	Check Status Menu and all parameters PASS/Ok. Backup configuration files to USB.
Serinus Cal 3000	UV Lamp check. Input Pot nominal value less than 255 otherwise replace lamp.
6 Monthly	
Serinus Cal 1000, 2000, 3000	MFC Multipoint Calibration MFC zero flow voltage check and adjustment (Refer to Section 6.4.4)
Serinus Cal 3000	Photometer Calibration - Transfer Standard (Portable)
Yearly	
Serinus Cal 2000, 3000	Ozone Flow Calibration

6.4 Maintenance Procedures

6.4.1 Leak Check Serinus Cal 3000

A Leak check is recommended when any service or repair of the internal valves or pneumatics has been performed or a leak is suspected.

Equipment Required

- Source of Vacuum (Pump)
- Leak Test Jig (PN: H050069)
- Assorted plugs and tubing supplied with instrument (Serinus Accessories Kit PN: H010136)

6.4.1.1 Leak Check - Full

1. Power ON the instrument.
2. Open - **Main Menu** → **Manual Operation Menu** → **Manual Point Menu**.
3. Select - **Mode** → **Idle**.
4. Remove the instrument lid.
5. Refer to Figure 162. Connect a leak test jig to the **Exhaust port** of the instrument.

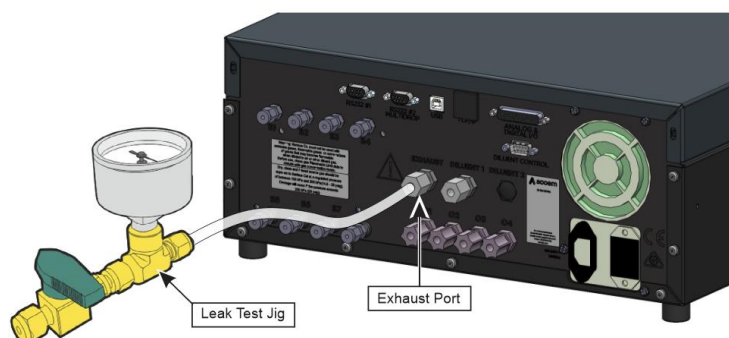

Figure 162 – Leak Test Jig to Exhaust Port

6. Connect a vacuum source to the shut off valve and ensure the shut off valve is in the open position.

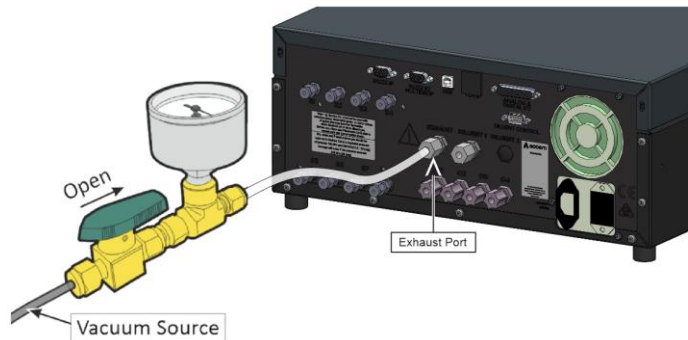

Figure 163 – Connect Vacuum Source

7. Block the output ports (O1 - O4) and the Diluent port with Kynar 1/4" blocker nut.

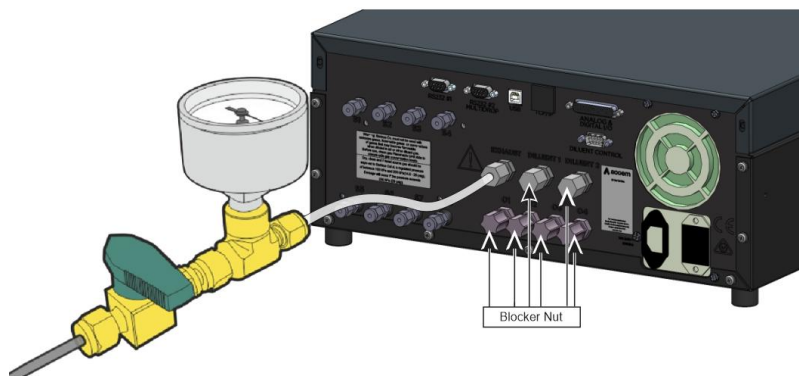

Figure 164 – Block the Output Ports

8. Disconnect ports J and C from the pressure regulator and cap the ends of the tube with 1/8" black caps. The pressure regulator has an internal bleed valve and your leak test **will not work** if the pressure regulator is not isolated.

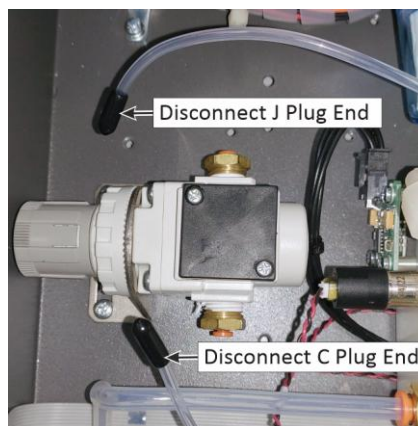

Figure 165 – Isolate Pressure Regulator

9. Navigate to **Main Menu** → **Manual Operation Menu**
10. Program a Manual Gas Dilution Point to provide 9.9 SLPM of Diluent AIR. If prompted by screen accept calculated gas output. The flow is not important, we only require the MFC's to be open for the leak test.

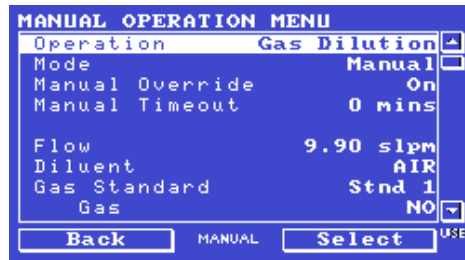

Figure 166 – Leak Check: Manual Point Setup

11. Navigate to **Main Menu → Service Menu → Diagnostics Menu → Valve Menu.**
12. Disable Valve Sequencing. Close all ports except “V8: Photometer” which is set to “Open”

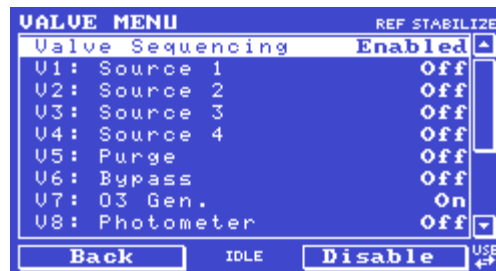

Figure 167 – Leak Check: Full Test

13. Apply a vacuum to the exhaust port and allow the instrument time to evacuate the pneumatic system (the time required will depend on the vacuum source used).
14. Close the shut off valve and record the vacuum indicated on the leak test jig. Wait for three minutes and observe the gauge on the leak test jig. It should not drop more than 2 kpa (15.0 torr).
15. If the leak test passes the test is complete. Reconnect port J and C, Enable Valve Sequencing and return operation mode to original state.
 - If the leak test fails continue to bypass pump, refer to section 6.4.1.2.

6.4.1.2 Leak Check - Bypass Pump

The next steps bypass the internal pump.

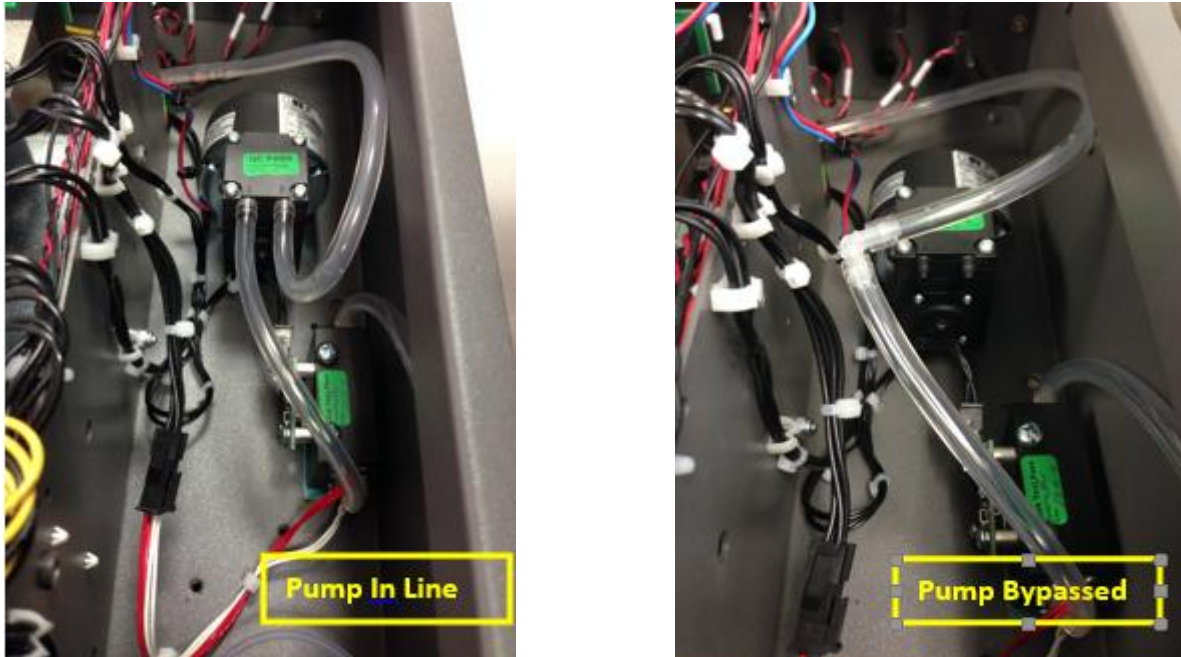

Figure 168 – Leak Check: Pump Bypass

1. Follow steps outlined in “Leak Check Full” procedure.
2. Bypass the pump with a barb elbow fitting as shown in figure above.
3. Apply a vacuum to the exhaust port, when stable close vacuum.
4. Wait 5 minutes, observe the gauge on the leak check jig.
 - **If the leak test passes** the pump is leaking. In the case of a small leak this can be ignored as the pump is at the end of the sample. For larger leaks service pump and retest. Return connections and menus to original state.
 - **If the leak test fails** continue to isolate Photometer.

6.4.1.3 Leak Check - Isolate Photometer

1. Follow steps outlined in “Leak Check Full” procedure. At **Step 8** Change V1 - V8 states to Closed.

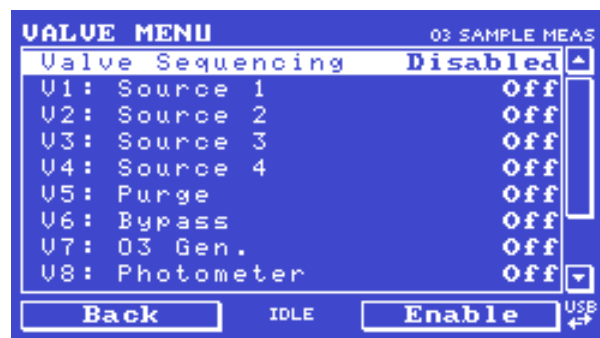

Figure 169 – Leak Check: Isolate Photometer Valve States

2. Apply a vacuum to the exhaust port, when stable close vacuum.
3. Wait 5 minutes, observe the gauge on the leak check jig.
 - **If a leak test fails** the photometer plumbing is leaking. Refer to Figure 170 and work away from vacuum test device to further isolate and rectify leak.

- If the leak test passes the photometer plumbing is not leaking. Continue steps to isolate MFC plumbing.

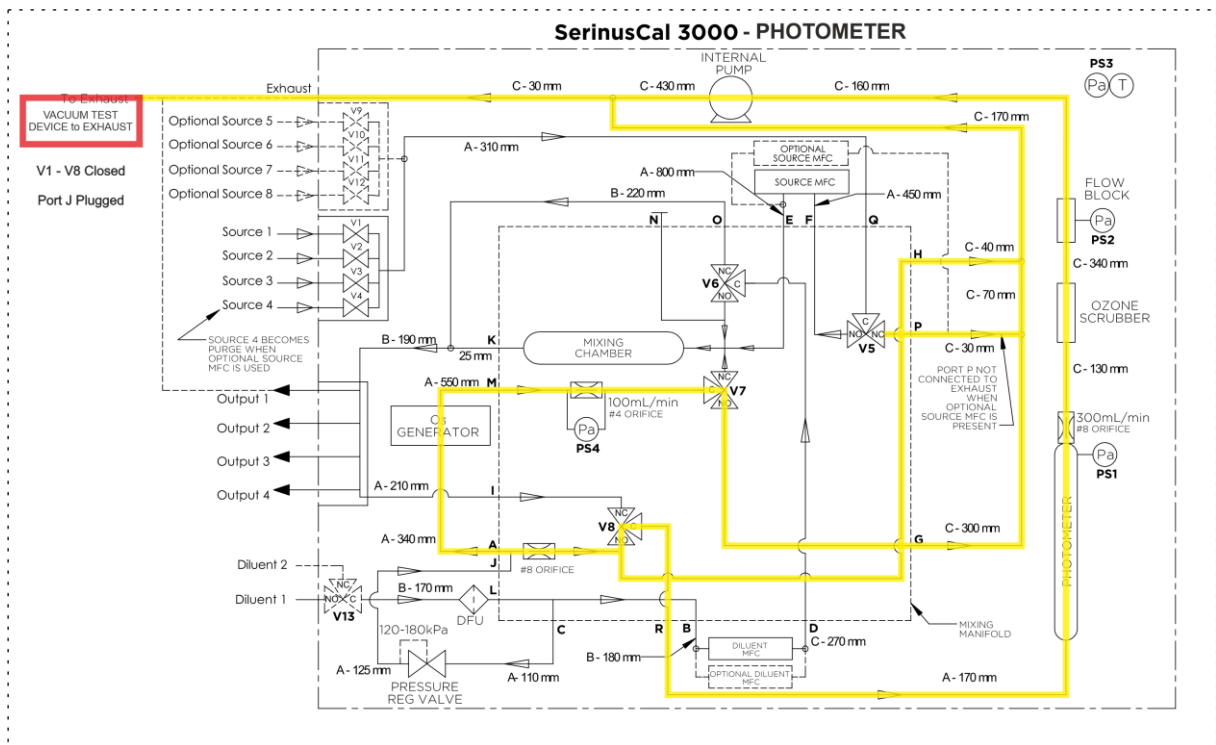

Figure 170 – Leak Check: Isolate Photometer Schematic

6.4.1.4 Leak Check - Isolate MFC's

1. Connect vacuum test device to any **output port** (O1 - O4). Plug all other output ports and diluent port.
2. Disable valve sequencing and set V1 - V8 states to all Closed.
3. Apply a vacuum to the output port, when stable close vacuum.
4. Wait 5 minutes, observe the gauge on the leak check jig.
 - If the leak test fails the MFC plumbing is leaking. Refer to Figure 171 and work away from the vacuum test device to further isolate and rectify leak.
 - If the leak test passes the test is complete.
5. Remove caps and re-connect ports J and C.
6. **Enable Valve Sequencing** and return instrument to previous operating Mode.

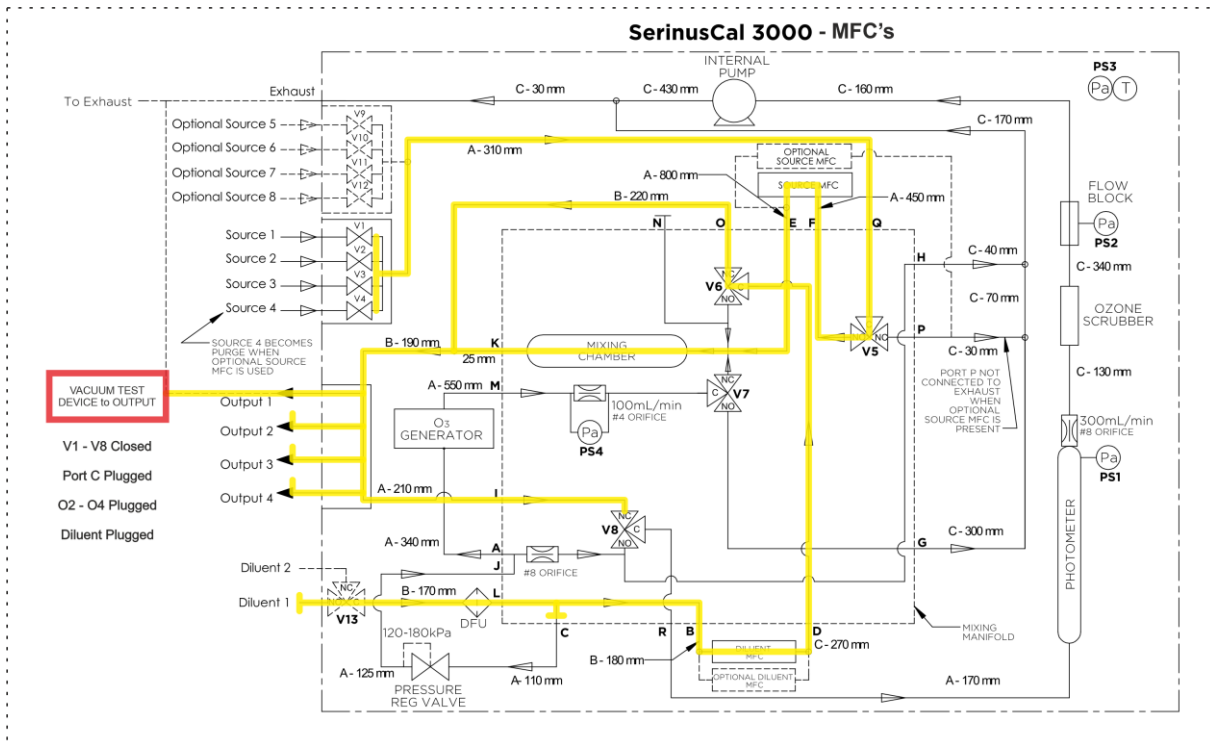

Figure 171 – Leak Check: Isolate MFC's Schematic

6.4.2 UV Lamp Check Serinus Cal 3000

The UV lamp intensity decreases over time, to compensate for this the instrument will increase the **Input pot**. When the **Input Pot** increases above 200 the lamps intensity is not suitable for accurate measurement and the UV lamp should be replaced.

Equipment Required

- 1.5 mm Hex Key

UV Lamp Replacement



CAUTION

The UV Lamp operates from Hazardous Live Voltages. Be sure to turn the instrument power OFF during UV lamp replacement. .



CAUTION

The UV Lamp emits harmful UV radiation. Be sure to turn the instrument power OFF during UV lamp replacement. Use UV protective eye were if it is necessary to observe if the lamp is operating correctly.

1. Turn the calibrator OFF.
2. Open the lid to access the photometer assembly (refer to Section 2.1, **Opening the Instrument**).
3. Disconnect the UV lamp from the lamp driver PCA (located under the photometer assembly).
4. Loosen the grub screw (1.5 mm hex key) located in the centre of the lamp block (refer to Figure 172) securing the UV lamp and slowly pull the UV lamp out of the block.

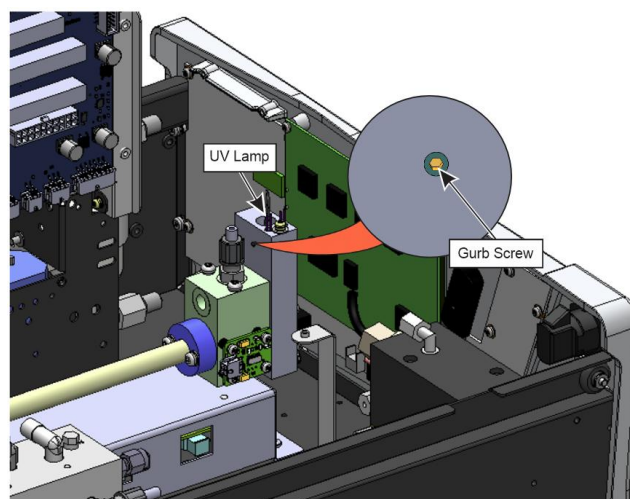

Figure 172 – Location of UV Lamp Securing Grub Screw

5. Install the new UV lamp in reverse order of the above steps. Be sure to insert the UV lamp completely in the block to achieve maximum signal strength.



CAUTION

Be careful when securing UV lamp with grub screw not to tighten the grub screw too much and damage lamp. The grub screw has a special rubber tip that protects the lamp housing but still holds the UV lamp in place.

6. Turn ON the instrument and allow one hour to stabilise.
7. Perform a photometer assembly calibration (refer to Section 5.6).

6.4.3 Cleaning

The instrument enclosure is made from aluminium and steel which are resistant to most forms of contamination. In order to keep the enclosure looking clean, use a microfiber cleaning cloth or a lightly dampened cloth. Be sure to turn the power OFF when doing so. The dilution calibrator is not water proof so large volumes of water may damage the instrument.

6.4.4 MFC zero flow voltage check and adjustment

Before You Start:

- Ensure the Serinus calibrator has been powered on for at least two hours and is in idle mode.
 - Disconnect any pressurised diluent gas.
1. Access Service Display: Enter the advanced menu and enable Service Display (.99+).



Figure 173 – Accessing the Service Display

2. **View MFC Voltages:** Navigate to the Analyzer Status menu and select "Voltage." The MFC voltages for all installed MFCs will be displayed at the bottom of the list. Record these values.

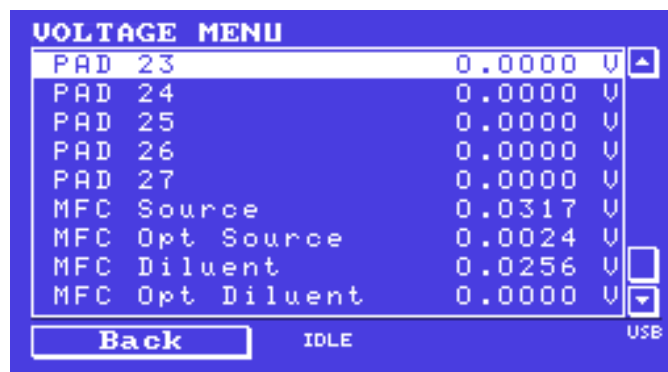

Figure 174 – MFC Voltage Display

Interpreting MFC Voltages:

Voltage Reading	Meaning	Action Required
~0.012 V (±0.005)	Nominal	No action required
0.000 V	Possible fault or miscalibration	Perform MFC zero adjustment
> 0.025 V	Out of tolerance	Perform MFC zero adjustment

Note: Ideally, the MFC voltage should average 0.012 V with no flow.
If the value is 0.000 V or greater than 0.025 V, a zero adjustment is required.

Adjustment Procedure:

- **Tool Required:** Trimmer Adjustment Tool.
- **Identify MFCs:** Determine which MFCs require adjustment based on voltage readings.



Figure 175 – Multi-MFC Setup Example (4 MFCs Installed)

Adjust Potentiometer: Using the trimmer adjustment tool, adjust the required MFC's zero flow potentiometer until the MFC voltage displays an average value of 0.012 volts on the instrument's voltage menu.



Figure 176 – Zero Flow Potentiometer Adjustment

Repeat: Repeat this process for all installed MFCs that require adjustment.



Figure 177 – Final Voltage Check

Final Steps: Reconnect and Verify

- Once all adjustments are complete, reconnect any pressurized dilution inlet tubing that was previously disconnected.

Note: The voltage readout does not display negative values.

6.5 Bootloader

The Serinus Bootloader is the initial set of operations that the instruments' microprocessor performs when first powered up (similar to the BIOS found in a personal computer). This occurs every time the instrument is powered up or during instrument resets. Once the instrument boots up, it will automatically load the instruments' firmware. A service technician may need to enter the Bootloader to perform advanced microprocessor functions as described in the following sections.

To enter the Bootloader, turn OFF the power to the instrument. Press and hold the plus key while turning the power ON. Hold the Plus key until the following screen appears.

```
** Acoem Serinus Cal **  
V3.4.0 Bootloader  
Press '1' to enter Bootloader
```

If the instrument displays the normal start up screen, the power will need to be toggled and another attempt will need to be made to enter the Bootloader. Once successful, press 1 on the keypad to enter the **Bootloader Menu**.

6.5.1 Display Help Screen

Once in the Bootloader screen it is possible to redisplay the help screen by pressing 1 on the keypad.

6.5.2 Communications Port Test

This test is very useful for fault finding communication issues. It allows a communication test to be carried out independent to any user settings or firmware revisions.

This command forces the following communication ports to output a string of characters: Serial Port RS232 #1, USB rear and Ethernet Port. The default baud rate is 38400 for the RS232 Serial Port. Initiate the test by pressing 2 on the keypad from the Bootloader screen.

6.5.3 Updating Firmware from USB Memory Stick

It is important for optimal performance of the instrument that the latest firmware is loaded. The latest firmware can be obtained by visiting Acoem website:

<https://www.acoem.com/australasia/serinus-firmware/>

Or by emailing Acoem at support-em@acoem.com

To update the firmware from a USB memory stick, use the following procedure:

Procedure

1. Turn the instrument OFF.

2. Place the USB memory stick with the new firmware (ensure that firmware is placed in a folder called FIRMWARE) in the front panel USB Port.
3. Enter the Bootloader (refer to Section 6.5).
4. Select option 3 (upgrade from USB memory stick), press 3 on the keypad.
5. Wait until the upgrade has completed.
6. Press 9 on the keypad to start the instrument with new firmware.

6.5.4 Erase All Settings

This command is only required if the instrument's firmware has become unstable due to corrupted settings. To execute this command, enter the **Bootloader Menu** (refer to Section 6.5) and press 4 on the keypad.

6.5.5 Start Calibrator

The start analyser command will simply initiate a firmware load by pressing 9 on the keypad from the **Bootloader Menu**. It is generally used after a firmware upgrade.

This page is intentionally blank.

7. Troubleshooting

7.1 Main Screen Error Messages

In the event of an instrument fault an error message will be displayed on the lower left corner of the home screen. It will also be logged on the internal USB memory stick as an event in the “Event Log”.

In addition, the green status led will change to orange or red.

- A red light indicates that the instrument has a major failure and is not functioning.
- An orange light indicates there is a minor problem with the instrument, but the instrument may still operate reliably.
- A green light indicates that the instrument is working and there are no problems.

To determine which component/s of the instrument is causing a fault the user can press the orange or red button to display a complete list of all current errors and warnings.

The user can also find the complete list of self-diagnostic checks at;

Main Menu → Analyser State Menu → Status Menu

Refer to Section 3.5.17 of this manual has a complete table and explanation of all fault conditions. If the user need further assistance please backup your instrument files to a USB memory stick and contact Acoem Support.

7.2 Technical Support Files

Regular backup of the settings, parameters and data on the instruments USB memory stick is recommended.

In the event of a fault that requires Acoem technical support, please make copies of the following files and email to: support-em@acoem.com

Equipment Required

- PC/Laptop

Procedure

State the ID number, model, board revision and firmware version of the instrument with a brief description of the problem. Take a copy of the current configuration if possible and a save of the parameters.

1. Open - **Main Menu → Analyser State Menu.**
2. **Model** - (take note).
3. **Instrument ID** - (take note).
4. **Board Revision** - (take note).
5. **Firmware Ver.** - (take note).
6. Open - **Main Menu → Service Menu.**
7. Save - **Save Configuration** - (CONFIG**.TXT) - Accept

Note: CONFIG99.TXT is the “Factory Backup” file, this is the configuration of the instrument as it left the factory. It is recommended that this file is kept unchanged but can be used as a reference backup point.

** Can be any number from 0 - 98.

8. Save - **Save Parameter List** - (PARAM**.TXT) - Accept.
9. Eject - **Safely Remove USB Stick** - (Follow instructions).

Note: PARAM99.TXT is the “Factory Backup” file, This is a snap shot of the parameters while it was under test in the factory just prior to release. It is recommended that this file is kept unchanged but can be viewed for reference.

** Can be any number from 0 - 98.

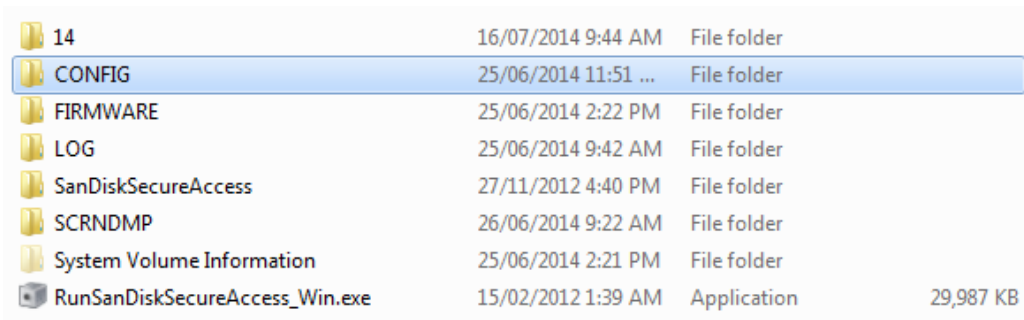

Item	Modified	Type	Size
14	16/07/2014 9:44 AM	File folder	
CONFIG	25/06/2014 11:51 ...	File folder	
FIRMWARE	25/06/2014 2:22 PM	File folder	
LOG	25/06/2014 9:42 AM	File folder	
SanDiskSecureAccess	27/11/2012 4:40 PM	File folder	
SCRNDMP	26/06/2014 9:22 AM	File folder	
System Volume Information	25/06/2014 2:21 PM	File folder	
RunSanDiskSecureAccess_Win.exe	15/02/2012 1:39 AM	Application	29,987 KB

Figure 178 – USB Memory Stick File Structure

10. Insert the USB memory stick into your PC/Laptop computer and access the files.
11. Best practice is to email all the on the USB memory stick but if it's too large just send:
12. The CONFIG**.TXT and PARAM**.TXT files that are saved in the CONFIG folder.
13. The LOG files (Event Log text files) and data files (14=Year, Sub folder=month).
14. Safely Eject the USB from the PC/Laptop and return to the instrument.

7.3 USB Memory Stick Failure

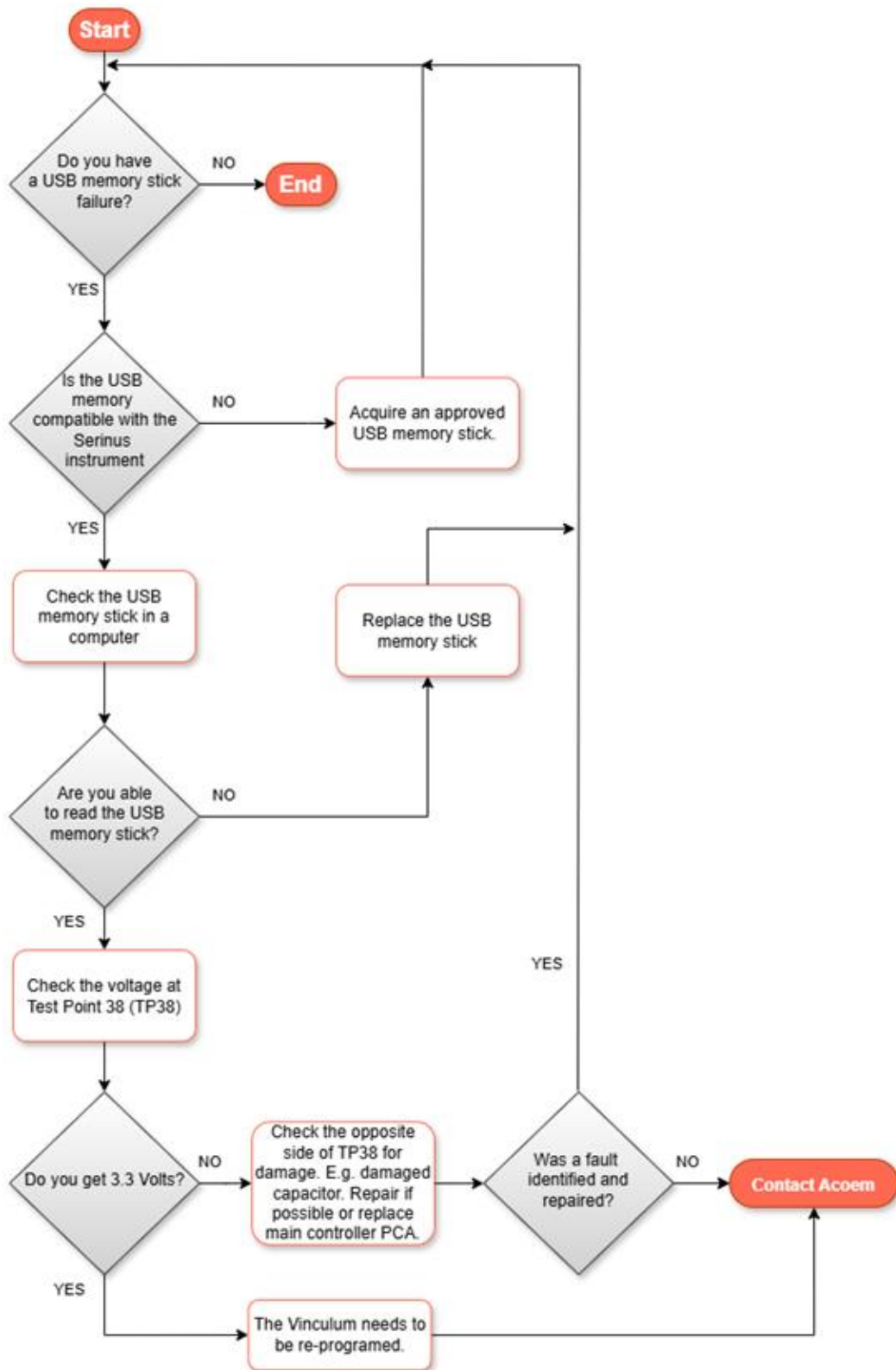

Figure 179 – USB Memory Stick Failure Diagnostic Procedure

Refer to Section 1.5.1.3 for USB memory stick usage and formatting requirements.

7.4 Lamp Temperature Failure

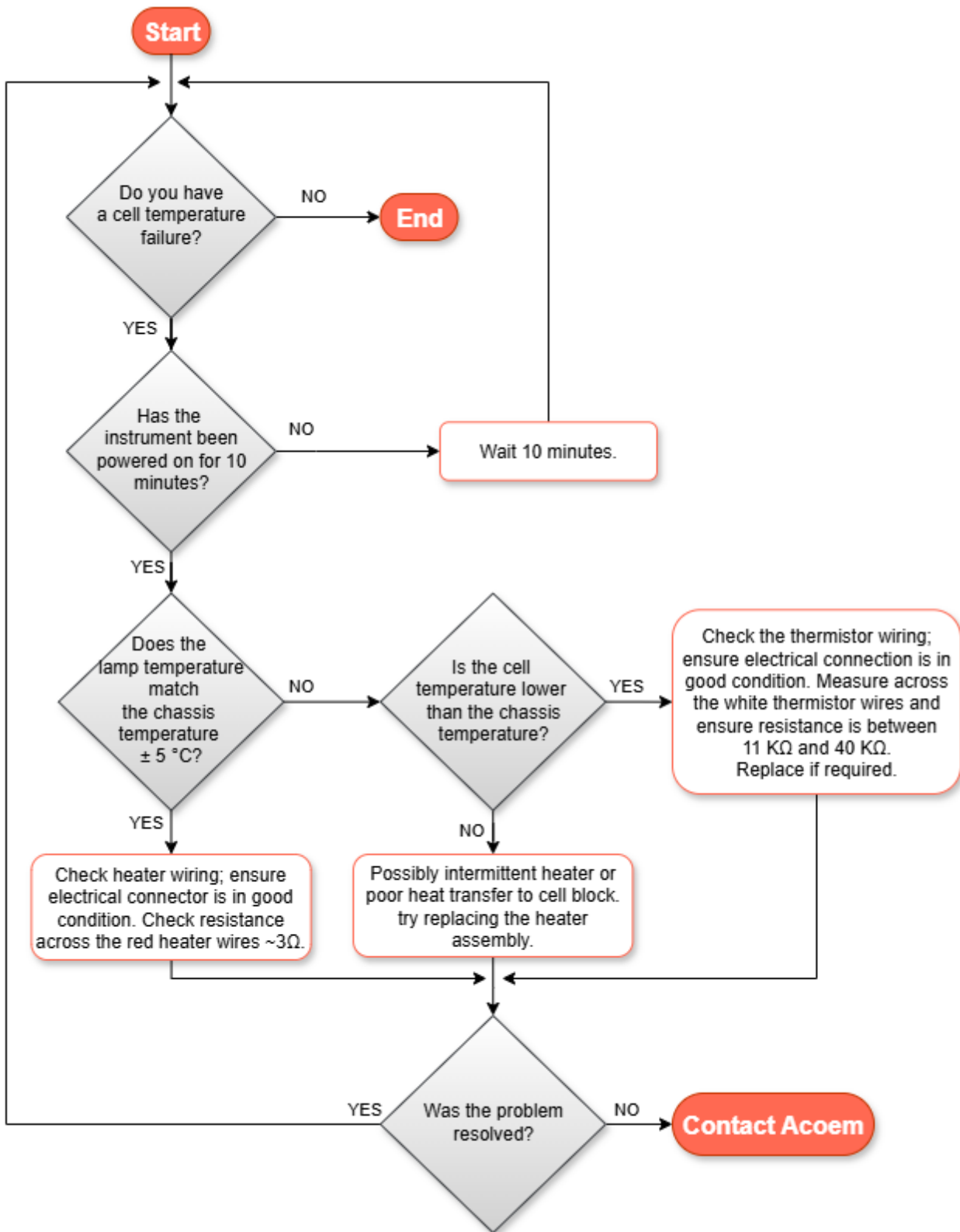

Figure 180 – Lamp Temperature Failure Diagnostic Procedure

8. Optional Extras

This section contains information on optional kits and installed options.

Rack Mount Kit	Refer to Section 8.1.
Network Port	Refer to Section 8.2.
Metric Fittings Kit	Refer to Section 8.3.
Additional Source Ports	Refer to Section 8.4.
Additional Diluent Port	Refer to Section 8.5.
Second Source MFC	Refer to Section 8.6.
Second Diluent MFC	Refer to Section 8.7.

8.1 Rack Mount Kit (PN: E020116)

The rack mount kit is necessary for installing the Serinus into a 19" rack (the Serinus is 4RU in height).

Table 8 – Included Parts (Rack Mount Kit)

Description	Quantity	Part Number
Rack Slide Set	1	H010112
Rack Mount Adaptors	4	H010133
Rack Mount Ears	2	H010134
Spacers	4	HAR-8700
M6 x 20 Button Head Screws	8	
M6 Washers	16	
M6 Nyloc Nuts	8	
M4 x 10 Button Head Screws	18	
M4 Washers	8	
M4 Nyloc Nuts	8	
M6 Cage Nuts	8	

Installing the Instrument

1. Remove the rubber feet from the instrument (if attached).
2. Refer to Figure 181. Separate the slide rail assembly by pressing the black plastic clips in the slide rails to remove the inner section of the rail.

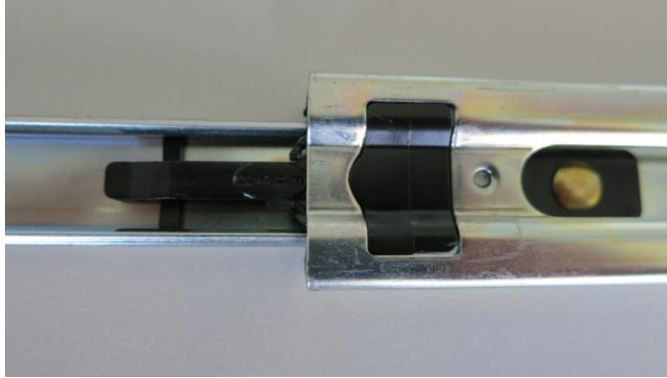

Figure 181 – Separate Rack Slides

3. Refer to Figure 182. Attach the inner slide rails to each side of the instrument using M4 x 10 button screws; three on each side.



Figure 182 – Assemble Inner Slide on Chassis

4. Refer to Figure 183. Install rack mount ears on the front of the instrument using two M4 x 10 screws on each side.



Figure 183 – Rack Mount Ears Fitted to Instrument

5. Refer to Figure 184. Attach the rack mount adaptors to the ends of the outer slide rails using M4 x 10 button screws, washers and locknuts. Do not fully tighten at this stage as minor adjustments will be required to suit the length of the rack.



Figure 184 – Attach Rack Mount Adaptors to Outer Slides

6. Refer to Figure 185. Test fit the rack slide into your rack to determine the spacing of the rack mount adaptors.

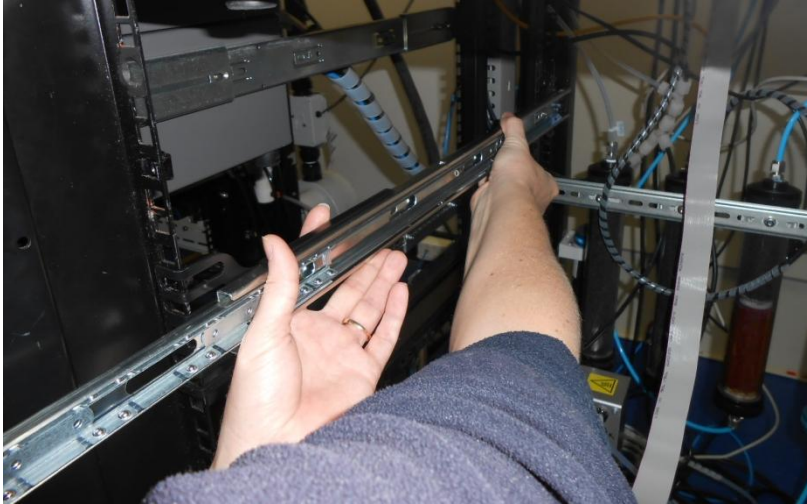

Figure 185 – Test Fit the Rack Slide Assembly into Your Rack

7. Refer to Figure 186 .Install the two assembled outer slide rails onto the left and right side of the rack securely with M6 bolts; washer and locknuts/cage nuts.

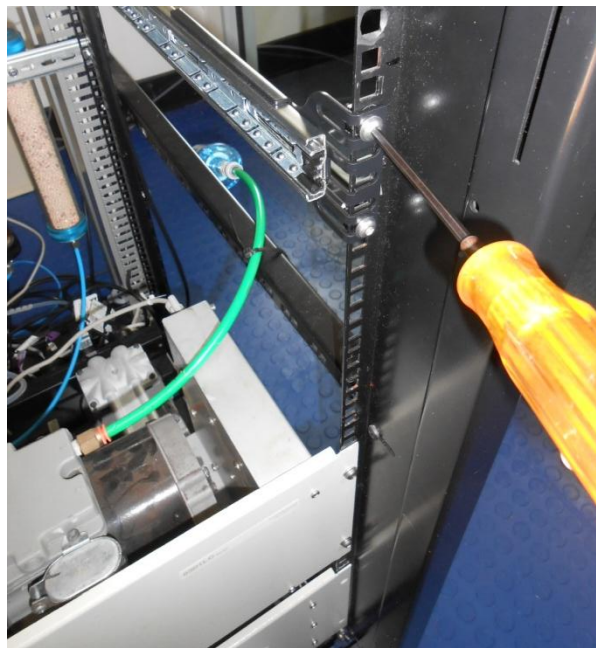

Figure 186 – Attach Slides to Front of Rack

8. Now carefully insert the instrument into the rack by fitting the instrument slides into the mounted rails. Ensuring that the rack slide locks engage on each side (the user will hear a click sound from both sides).



CAUTION

When installing this instrument ensure that appropriate lifting equipment and procedures are followed. It is recommended that two people lift the instrument into the rack due to the weight, unless proper lifting equipment is available.

Note: Ensure both sides of the inner slide are attached to the outer slides before pushing into the rack fully.

9. Push the instrument into the rack. Adjust and tighten the screws as required to achieve a smooth and secure slide.

To Remove the Instrument

1. To remove the instrument first pull instrument forward of rack giving access to the slides.
2. Refer to Figure 187. Find the rack slide lock labelled **Push** and push it in whilst sliding the instrument out of the rack, complete this for both sides while carefully removing instrument.

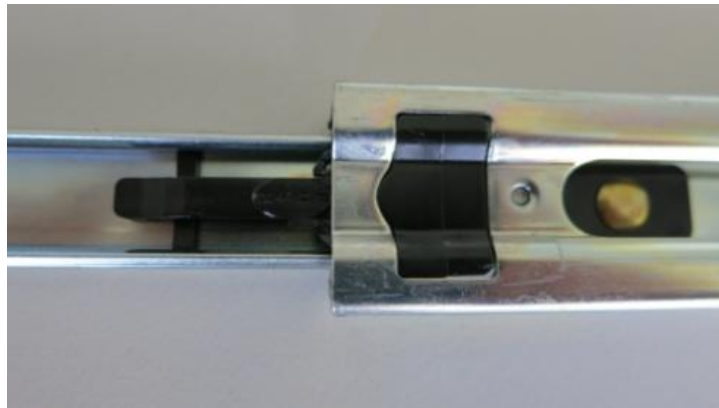

Figure 187 – Slide Clips

8.2 Network Port (PN: E020317)

The network port option allows the user to setup and connect to a range of TCP/IP network options. If user have this option installed, they need to make sure it is enabled in the **Hardware Menu** before the feature can be used.

Table 9 – Network Port Parts Added

Part Description	Quantity	Part Number
Rear Panel PCA (Network Port)	1	C010002-20

Note: For Serinus Cal models, the equivalent factory-installed network port option is PN: E020317.

Table 10 – Network Port Parts Removed

Part Description	Quantity	Part Number
Rear Panel PCA	1	C010002-02
Rectangular Blanking Plug	1	H010067

- Refer to Section 3.5.42, for details on the network menu.
- Refer to Section 4.3, for details on network setup.

8.2.1 Hardware Setup

This procedure will need to be followed after a factory reset.

Procedure

1. Press - (the green instrument status light button), this will take the user to the home screen.
2. Press - (-99+) on the keypad. This will open the **Advanced Menu**.
3. Open - **Advanced Menu** → **Hardware Menu**.
4. Enable - **Network Port** → **Enabled**.

8.3 Metric Fittings Kit (PN: E020122)

The metric fittings kit allows the user to connect 6 mm tubing to the rear ports of the instrument. This can be very handy if it is hard to source 1/4" tubing from a local supplier.

8.4 Additional Source Ports (PN: E020314)

An optional second inlet manifold can be purchased in order to increase the number of source gases from 4 to 8. If the user has this option installed, they need to make sure it is enabled in the **Hardware Menu** before the feature can be used.

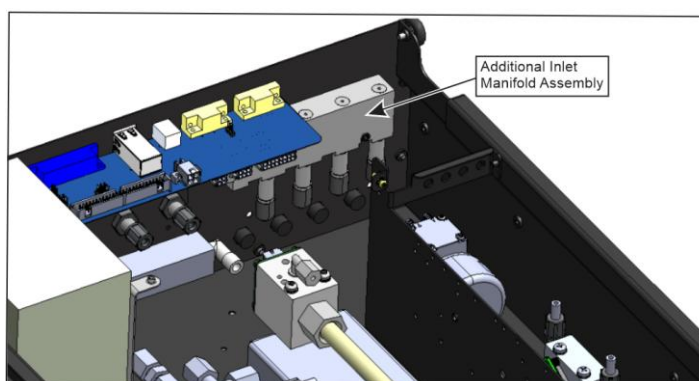

Figure 188 – Additional Source Ports

Table 11 – Additional Source Ports Parts Added

Part Description	Quantity	Part Number
Inlet Manifold Assembly	1	H013163
Optional Source Valves Cable	1	C020128
Swagelok Union Tee Fitting	1	28330200-3
Spacer 6.35 x 6 mm	2	HAR-8712

8.4.1 Hardware Setup

This procedure will need to be followed after a factory reset.

Procedure

1. Press - (the green instrument status light button), this will take the user to the home screen.
2. Press - (-99+) on the keypad. This will open the **Advanced Menu**.
3. Open - **Advanced Menu** → **Hardware Menu**.

4. Enable - **Opt. Source Ports** → **Enabled**.

Now the **Gas Supply Menu** will display four extra fields, **Source Port 5...8**.

8.5 Additional Diluent Port (PN: E020315)

An additional diluent port can be purchased as an optional extra where two different types of diluent are desired. Along with the extra port there is a valve manifold that enables switching between the two diluent sources.

The user can define the following diluent gases in the firmware AIR; NH₃, CO, CO₂, CH₄, H₂S, NO, NO₂, N₂, SO₂, C₂H₆, C₃H₈, C₄H₁₀, HE, O₂ and O₃ with the corresponding mass flow correction factor automatically being applied in the instrument.

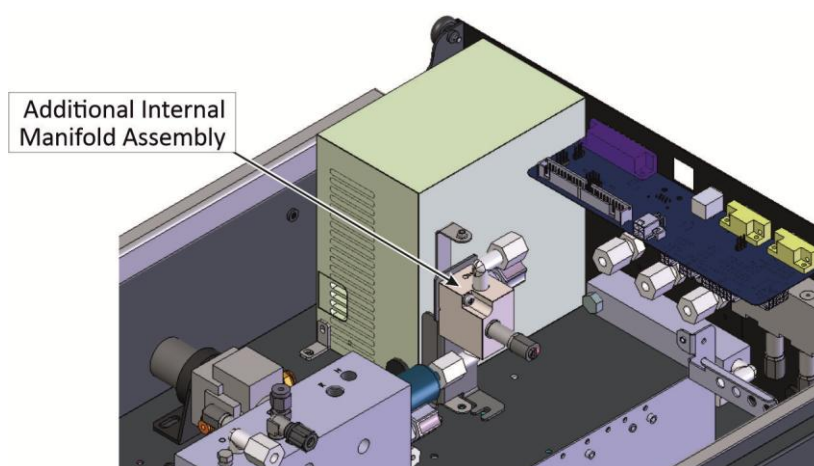

Figure 189 – Additional Diluent Port

Table 12 – Additional Diluent Ports Parts Added

Part Description	Quantity	Part Number
Internal Manifold Assembly	1	H013180
Optional Diluent Cable	1	C020129
Internal Manifold Gasket	1	H013186
Diluent Valve Bracket	1	H013154
Kynar Bulkhead Union Fitting	1	F030023

8.5.1 Hardware Setup

This procedure will need to be followed after a factory reset.

Procedure

1. Press - (the green instrument status light button), this will take the user to the home screen.
2. Press - (-99+) on the keypad. This will open the **Advanced Menu**.
3. Open - **Advanced Menu** → **Hardware Menu**.
4. Enable - **Dual Diluent Valve** → **Enabled**.

Now there will be a **Diluent Port 2** in the **Gas Supply Menu**.

8.6 Second Source MFC (PN: E020318-XX)

This option allows the user to expand the range of dilution ratios that are achievable through the calibrator.

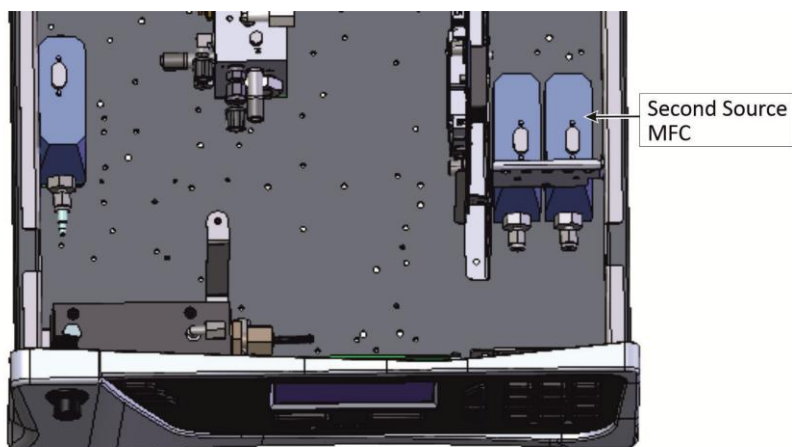

Figure 190 – Second Source MFC

Note: When this option is enabled, source port four is no longer available as a source port. Instead it is converted into a purge port. The purge port must be connected to an exhaust manifold venting to a suitable location outside the room and away from the sample inlets of any gas analyser in the system.

Table 13 – Second Source MFC Parts Added

Part Description	Quantity	Part Number
Mass Flow Controller - 10 SCCM	1	M050001
Or		
Mass Flow Controller -20 SCCM	1	ZUN-UFC18020SCCM
Or		
Mass Flow Controller - 50 SCCM	1	UFC18050SCCM
Or		
Mass Flow Controller - 100 SCCM	1	ZUN-UFC180-100CC
Or		
Mass Flow Controller - 200 SCCM	1	ZUN-UFC180-200CC
Or		
Mass Flow Controller - 500 SCCM	1	ZUN-UFC180-500CC
Or		
Mass Flow Controller - 1000 SCCM	1	ZUN-UFC1801000CC
Or		
Mass Flow Controller - 2000 SCCM	1	ZUN-UFC180-002L
Or		
Mass Flow Controller - 5000 SCCM	1	ZUN-UFC180-005L

Part Description	Quantity	Part Number
Mass Flow Controller Gasket	1	HAR-6100
Kynar Union Tee Fitting	1	F030034-01
Male Elbow Swagelok Fitting	1	F030025
1/4T - 1/8T Union Reducer Swagelok Fitting (Added only with 500, 1000, 2000, 5000 SCCM MFC Option)	1	28280402-3
1/4T Port Connector Swagelok Fitting (Added only with 500, 1000, 2000, 5000 SCCM MFC Option)	1	28430400-3
1/4T - 1/8T Reducing Ferrule (Added only with 500, 1000, 2000, 5000 SCCM MFC Option)	1	F030031

Table 14 – Second Source MFC Removed

Part Description	Quantity	Part Number
1/4T Tee Union Fitting	1	F030210-01
1/4T Ferrule	4	F030203-01
1/4T Compression Nut Fitting	4	F030202-01
1/4T - 1/8NPT Male Elbow Fitting	1	F030201-01

8.6.1 Hardware Setup

This procedure will need to be followed after a factory reset.

Procedure

1. Press - (the green instrument status light button), this will take the user to the home screen.
2. Press - (-99+) on the keypad. This will open the **Advanced Menu**.
3. Open - **Advanced Menu** → **Hardware Menu** → **MFC Installation Menu**.
4. Select - **MFC Opt Source** - (select form the list the MFC ordered as an option).

Now the user can enter the co-efficients if they are known or run a MFC calibration (refer to Section 5.1).

8.7 Second Diluent MFC (PN: E020316-XX)

This option allows the user to expand the range of dilution ratios that are achievable through the calibrator.

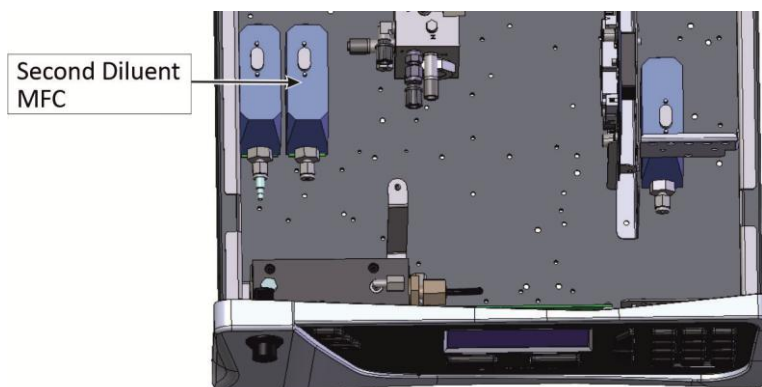

Figure 191 – Second Diluent MFC

Table 15 – Second Diluent MFC Parts Added

Part Description	Quantity	Part Number
Mass Flow Controller - 1000 SCCM	1	ZUN-UFC1801000CC
Or		
Mass Flow Controller - 2 Litre	1	ZUN-UFC180-002L
Or		
Mass Flow Controller - 5 Litre	1	ZUN-UFC180-005L
Or		
Mass Flow Controller - 10 Litre	1	ZUN-UFC180-010L
Or		
Mass Flow Controller - 20 Litre	1	ZUN-UFC180-20L
Mass Flow Controller Gasket	1	HAR-6100
1/4T Tee Union Kynar Fitting	1	F030034-02
1/4T Compression Fitting Nut	4	F030202-01
1/4T Ferrule	4	F030203-01
1/4T - 1/4 Stub Adaptor Fitting	1	F030207-01
1/4T Tee Union Fitting	1	F030210-01

8.7.1 Hardware Setup

This procedure will need to be followed after a factory reset.

Procedure

1. Press - (the green instrument status light button), this will take the user to the home screen.
2. Press - (-99+) on the keypad. This will open the **Advanced Menu**.
3. Open - **Advanced Menu** → **Hardware Menu** → **MFC Installation Menu**.
4. Select - **MFC Opt Diluent** - (select from the list the MFC ordered as an option).

Now the user can enter the co-efficients if they are known or run a MFC calibration (refer to Section 5.1).

9. Spare Parts and Schematics

9.1 Maintenance Kit (PN: E020321, E020322, E020323)

Routine maintenance parts that may be required.

Table 16 – Serinus Cal 1000 Maintenance Kit (PN: E020321)

Description	Part Number
DFU Filter, 23 Micron	F010005
O-ring 7.5 X 1.0	O010046
Acoem Tubing, 1/4 X 1/8, (3 ft)	T010026

Table 17 – Serinus Cal 2000 Maintenance Kit (PN: E020322)

Description	Part Number
DFU Filter, 23 Micron	F010005
Compression Spring, SS	H010062
O-ring 5/32 ID X 1/16 W	O010013
O-ring 7.5 X 1.0	O010046
Acoem Tubing, 1/4 X 1/8, (3 ft)	T010026

Table 18 – Serinus Cal 3000 Maintenance Kit (PN: E020323)

Description	Part Number
DFU Filter, 23 Micron	F010005
Compression Spring, SS	H010062
O-ring 1/2ID X 3/32W	O010005
O-ring 0.489ID X 0.070W	O010008
O-ring 0.114ID X 0.07W	O010012
O-ring 5/32ID X 1/16W	O010013
O-ring .364ID X .07W	O010024
O-ring .359ID X .139W	O010025
O-ring 8.0 X 1.0	O010046
Acoem Tubing, 1/4 X 1/8, (3 ft)	T010026

9.2 Serinus Cal Service Kit (PN: E020320)

Assorted fittings, tubing and orifice removal tool useful when working on the instrument's internal pneumatics.

Table 19 – Serinus Accessories Kit

Part Description	Part Number
1/4 T Kynar Fitting Nut	036-130440-2
1/4T Swagelok Fitting Nut	28800400-3
1/4T Swagelok Fitting Ferrule	28820400-3
1/8T Swagelok Fitting Plug	28840200-3
1/4T Swagelok Fitting Plug	28840400-3
1/8T Swagelok Fitting Cap	28860200-3
1/4T Swagelok Fitting Cap	28860400-3
Kynar Fitting Union Tee 1/8 Barb	F030007-01
Kynar Fitting Union 1/8 Barb	F030008
Kynar Fitting Union Tee 1/8T	F030034-01
1/4T Compression Fitting Nut	F030202-01
1/4T Suit Compression Ferrule	F030203-01
1/4T - 1/4 Stub Compression Fitting Adaptor	F030207-01
1/4T Compression Fitting Union Tee	F030210-01
1/4" Fitting to 1/8" Barb Adaptor	H010007
1/4" Tube to 1/8" Barb Adaptor	H010008
Orifice and Filter Extraction Tool	H010046
1/8 Black Rubber Cap	H030003
Acoem Tubing 1/4 x 1/8	T010026
Teflon Tubing 1/8	TUB-1000

9.3 Consumables

Instrument components that will require replacement over the course of the instrument's lifespan.

Table 20 – Serinus Cal Consumables

Part Description	Model	Part Number	Replacement Lifespan Estimate*
Acoem Tubing, 25 ft Length	1000, 2000 & 3000	T010026-01	Subject to use
UV Lamp Assembly (Photometer)	3000	C020077	2 Years+
UV Lamp Assembly (Ozone Generator)	2000 & 3000	C020124-50	2 Years+
Silicone Heatsink Compound 50g	1000, 2000 & 3000	C050013	Subject to use

Part Description	Model	Part Number	Replacement Lifespan Estimate*
#4 Orifice	2000 & 3000	H010043-02	Subject to use
#8 Orifice	3000	H010043-06	Subject to use
Serinus CAL Pump Assembly	3000	H010030	6 months+
DFU Filter, 23 Micron	1000, 2000 & 3000	F010005	12 months+
Ozone Scrubber	3000	H013120	2 Years+

***Warranty Disclaimer:** The product is subject to a warranty period on parts and labour from the date of shipment (the warranty period). The warranty period commences when the product is shipped from the factory. **Lamps, fuses, batteries and consumable items are not covered by this warranty.**

Subject to use refers to variable ambient conditions, toxic gases, dirt, extremes of temperature and moisture ingress may shorten the lifespan of components.

9.4 Instrument Parts List

List of Serinus Cal 1000, 2000 and 3000 components and part numbers for user reference.

Note: Before refer to the spare part number confirm the part number and its location in attached drawings.

Table 21 – Spare Parts List (Main Components)

Part Description	Part Number
Rear Panel PCA – Serinus Cal (Without Network Port)	C010002-02
Rear Panel PCA – Serinus Cal (With Network Port – Tested Version)	C010002-20
Main Controller PCA	E020220-02
DFU Filter, 23 Micron	F010005
Internal Pump Assembly	H010030
Calibrator Back Panel	H010129-03
Front Panel Assembly	H010130
LCD Display	D010001-50
Power Supply	P010013
Photometer Assembly	H013100-01
Pressure Sensor PCA (Reaction Cell)	C010004
Lamp Driver PCA	C010006-01
Detector PCA	C010007-02
Heater Thermistor Assembly (Reaction Cell and Auxiliary Valve Manifold)	C020073

Part Description	Part Number
UV Lamp Assembly (Optical Bench)	C020077
Sintered Filter (Reaction Cell)	F010004
Gasket for Pressure Sensor PCA	H010037
#8 Orifice (Auxiliary Valve Manifold)	H010043-06
Compression Spring (Optical Bench)	H010062
Detector (Optical Bench)	H013111-01
Quartz Window (Optical Bench)	H013112
Glass Measurement Cell	H013113
Ozone Selective Scrubber	H013120
Ozone Generator Assembly	H013150
Ozone Generator PCA	C010012
UV Lamp Assembly	C020124-01
Ozone Generator Block	H013151
Ozone Generator Gasket	H013152
Inlet Manifold Assembly	H013160
3 Way Bullet Valve	H010058
Flow Block Assembly	H013165
Flow Block Assembly Restrictor Block	H010019
Output Manifold Assembly	H013170-01
Mixing Manifold Assembly	H013185
Pressure Differential PCA	C010005-01
Thermistor Assembly	C020142
#4 Orifice (Auxiliary Valve Manifold)	H010043-02
Ozone Mixing Manifold Block	H013184
Mass Flow Controller Gasket	HAR-6100
Pressure Regulator	R010002-01
FQA Kit	H050080

Table 22 – Spare Parts List (Cables)

Part Description	Part Number
Pressure Sensor Cable (Reaction Cell)	C020062-02
Display Cable	C020065
Analog & Digital I/O Cable	C020066
Detector PCA Cable	C020080
Heater and Thermistor Cable	C020083
Bluetooth Cable	C020119

Part Description	Part Number
Heater Cable	C020125
Ozone Valve Cable	C020126
Ozone Flow Block Cable	C020127
Mass Flow Control Cable	C020130
Standard Valves Cable	C020131-01
Ozone Generator Controller Cable	C020132-01
Lamp Driver Cable	C020141

Table 23 – Spare Parts List (O-rings)

Part Description	Part Number
O-ring, 1/2 ID X 3/32 W	O010005
O-ring, 1/2 ID X 1/16 W	O010008
O-ring, 0.114 ID X 1/16 W	O010012
O-ring 5/32 ID X 1/16 W (Reaction Cell Orifice)	O010013
O-ring, 0.364 ID X 0.07 W, BS012	O010024
O-ring, 0.359 ID X 0.139 W, BS204	O010025
7.5 X 10 O-ring	O010046

Table 24 – Spare Parts List (Fittings)

Part Description	Part Number
Kynar Union Fitting	F030022
1/4" PTEF Straight Ferrule	F030028
Nut 1/4T Steel Gripper Fitting	F030029
Kynar Union Elbow Fitting	F030030
Kynar Union Tee Fitting	F030034-02
1/4 BSPT to 1/8T Fitting	F030036
1/4T Compression Fitting Nut	F030202-01
1/4T Suit Compression Ferrule	F030203-01
Fitting Adaptor	F030207
1/4T Union Tee Fitting	F030210-01
Kynar Bulkhead Union Fitting	F030023
Kynar Fitting Nut 1/4T (Double Plastic Ferrule)	F030024
Bulkhead Union Fitting	F030212
Kynar Male Elbow Fitting 1/8T - 1/8NPT	28001146-1
Male Elbow Fitting	F030201-01

Part Description	Part Number
Kynar Male Connector Fitting	28001143-6
3/8 Straight Ferrule	F030002
M4 X 8 Pan Head Phillips Screw	F050022
M4 X 50 SS Screw	F050099
Kynar Plug 1/8 NPT (Source Timing Assembly)	HAR-3660
Male Swagelok Fitting	28100202-3
Male Elbow Fitting	F030025
Male Elbow Fitting	F030201
Kynar Male Connector Fitting	28001143-1
Kynar Male Connector Fitting 1/4T, 1/8 NPT	F030020
Kynar Male Elbow Fitting	F030032-02
Fitting Plug 1/16 NPT	F030015
3/4 BSPT SS Plug Fitting	F030076
Male Connector Fitting	F030200
M3 X 6 Pan Head Phillips Screw	F050011
SMC Male Connector Fitting	FIT-KQ2H07-02S
Spacer 6.35 mm OD X 6 MM L (Auxilaray Valve Manifold)	HAR-8712
1/4 Kynar Plug Fitting Nut	036-130440-2

Table 25 – Spare Parts List (Miscellaneous)

Part Description	Part Number
PCB Support Bracket	H010011-02
9/16" High Foot Bumper	H010039
Black Blanking Plug	H010041
11 mm Black Blanking Plug	H010059
Front Panel Clearance Spacer	H010064
Network Port Blanking Plug	H010067
Main Controller PCA Support Bracket (Rear Panel Side)	H010111-01
Roller Bearing	H010131
Power Supply Bracket	H010138
Push Button Slam Lock	H030114
Nylon P Clip, 1/2" (12.7 mm)	H030149
#40 Scrubber Support Ring	H010114
Main Controller PCA Support Bracket (Front Panel Side)	H010117-01
Flow Block Thermal Isolator	H010119
M3 X 6 Standoff, Male-Female	F050016

Part Description	Part Number
M3 X 5 Grub Screw	F050044
Ozone Cell Mounting Bench	H013101
Ozone Cell Tube Cover	H013102
Sensor Housing (Detector Side)	H013103
Mounting Block (Lamp Side)	H013104
Mounting Block (Detector Side)	H013105
Lamp Mounting Block	H013106
Tube Collet	H013107
Cover Collet	H013108
12 mm x 22.8 m Velcro Strap	98412052
Cover (Lamp Driver PCB)	H012108
8 GB USB Memory Stick	H030021
Pressure Regulator Bracket	H030093
Cable Clip Mount 13.5 X 14 mm (L X H)	H030121
Cable Clip Mount 13.5 X 14 mm (L X H)	H030122
Acoem Tubing	T010026
Teflon Tubing 1/8	TUB-1000
1/4" Teflon Tubing	TUB-1007
Thumb Screw (Rear Panel)	F050037
Thumb Screw (Main Controller PCA)	F050120
Green Acoem Resources USB Stick	H030137-01
USB Cable	COM-1440
Male Solder End	CON-1240
1/4 Black Rubber Cap	H030004
1/4 Blue Nylon Tubing	T010002

Table 26 – Spare Parts List (Shipping)

Part Description	Part Number
Desiccant Pack (25 gm)	C050012
Shipping Box	B010002
End Caps (Pair)	B010026
Plastic Bag 760 X 1000 50 X UM	B020001
Shipping Box	B010015
Mid Support Cap	B010034

9.5 Plumbing Schematic (Serinus Cal 1000) - (PN: D020034)

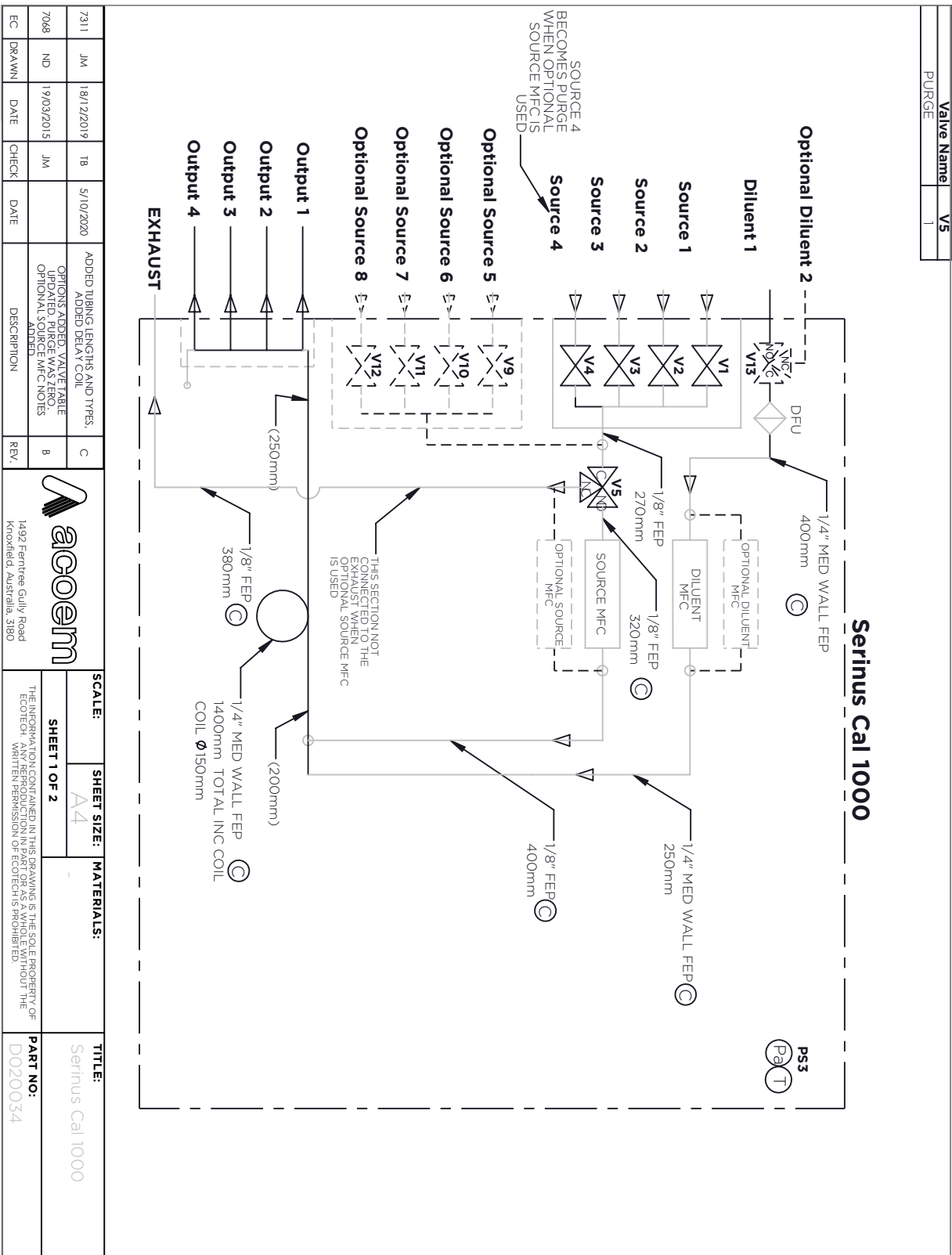

9.6 Plumbing Schematic (Serinus Cal 2000) - (PN: D020035)

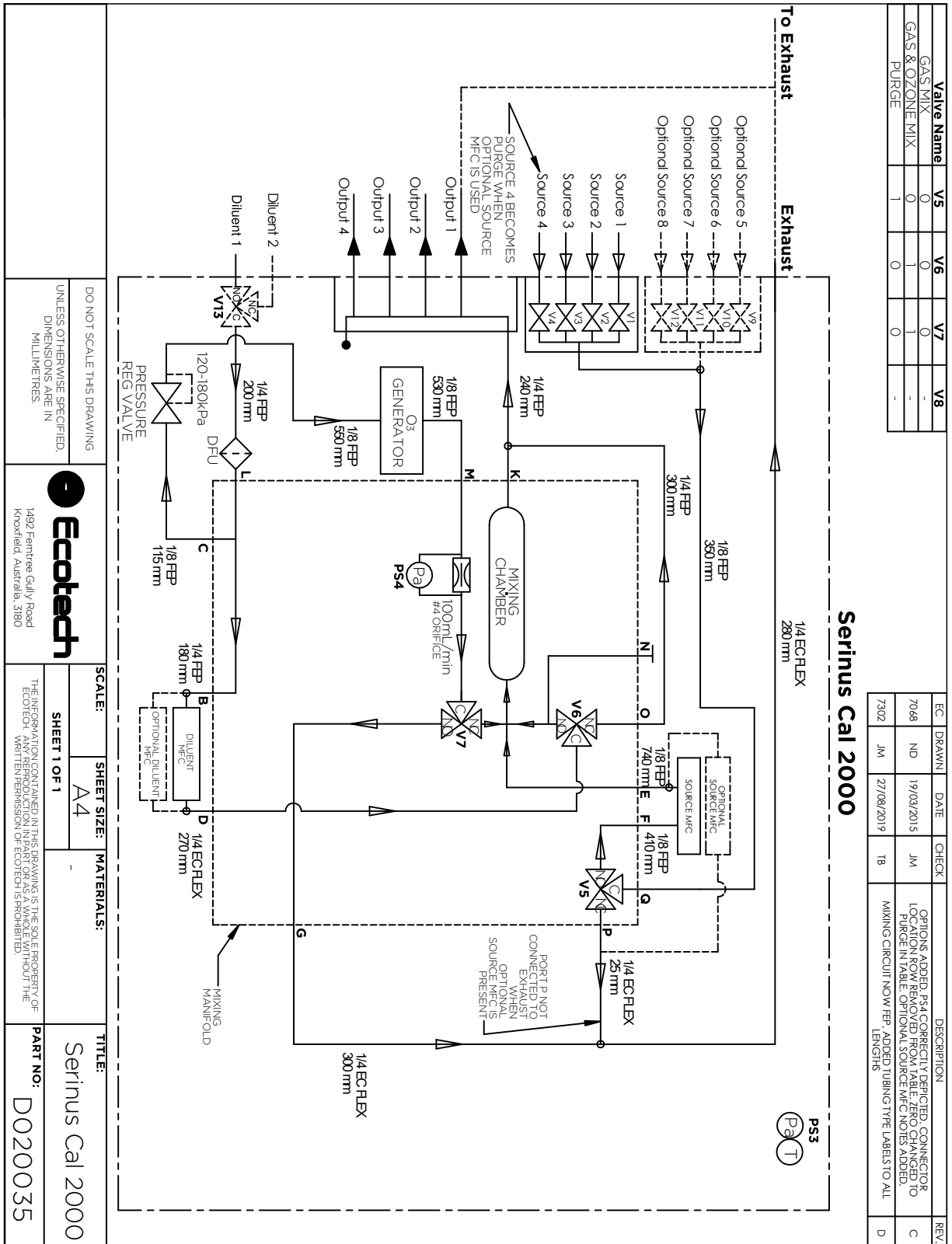

9.7 Plumbing Schematic (Serinus Cal 3000) - (PN: D020036)

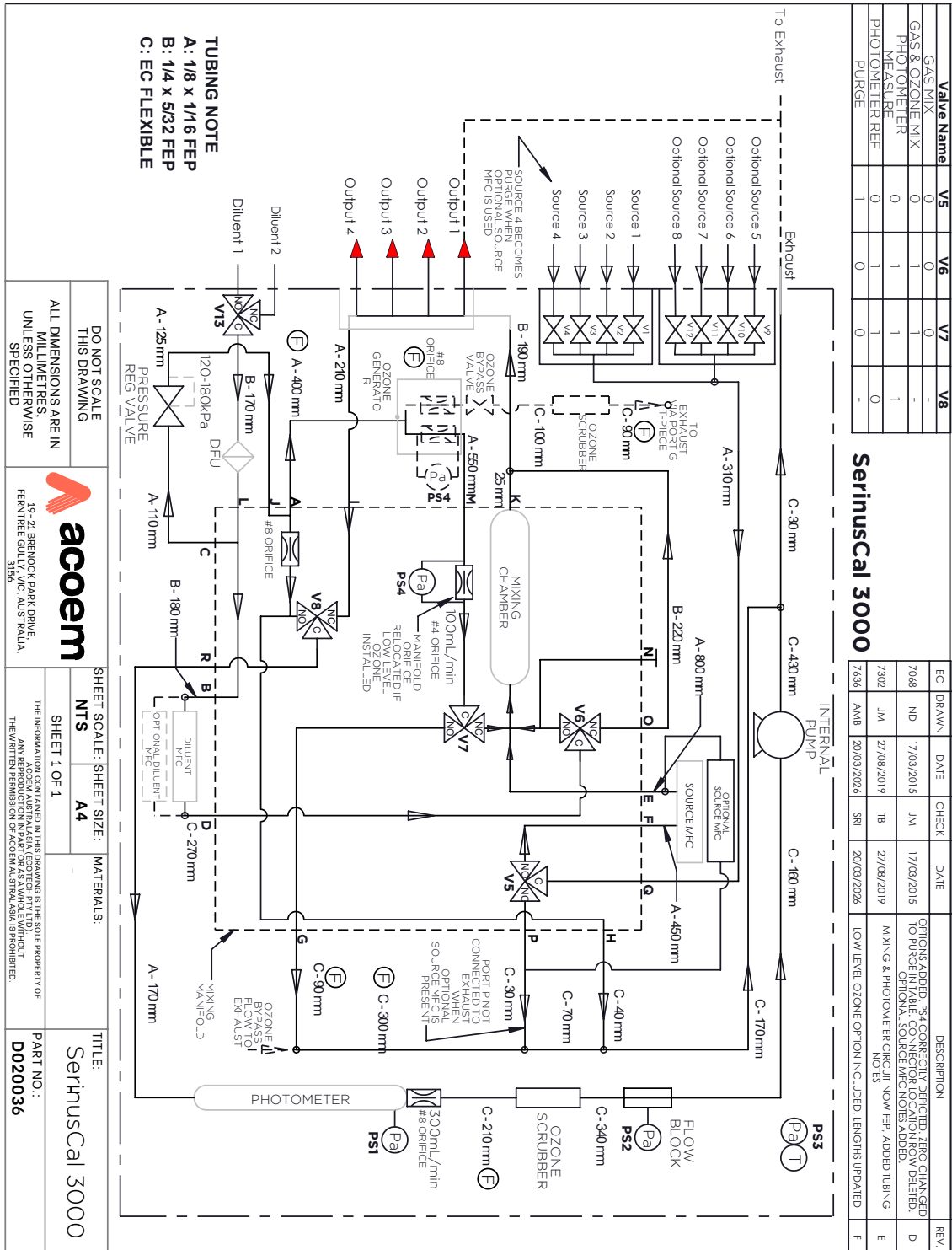

9.8 Block Wiring Schematic (Serinus Cal 1000) - (PN: D020037)

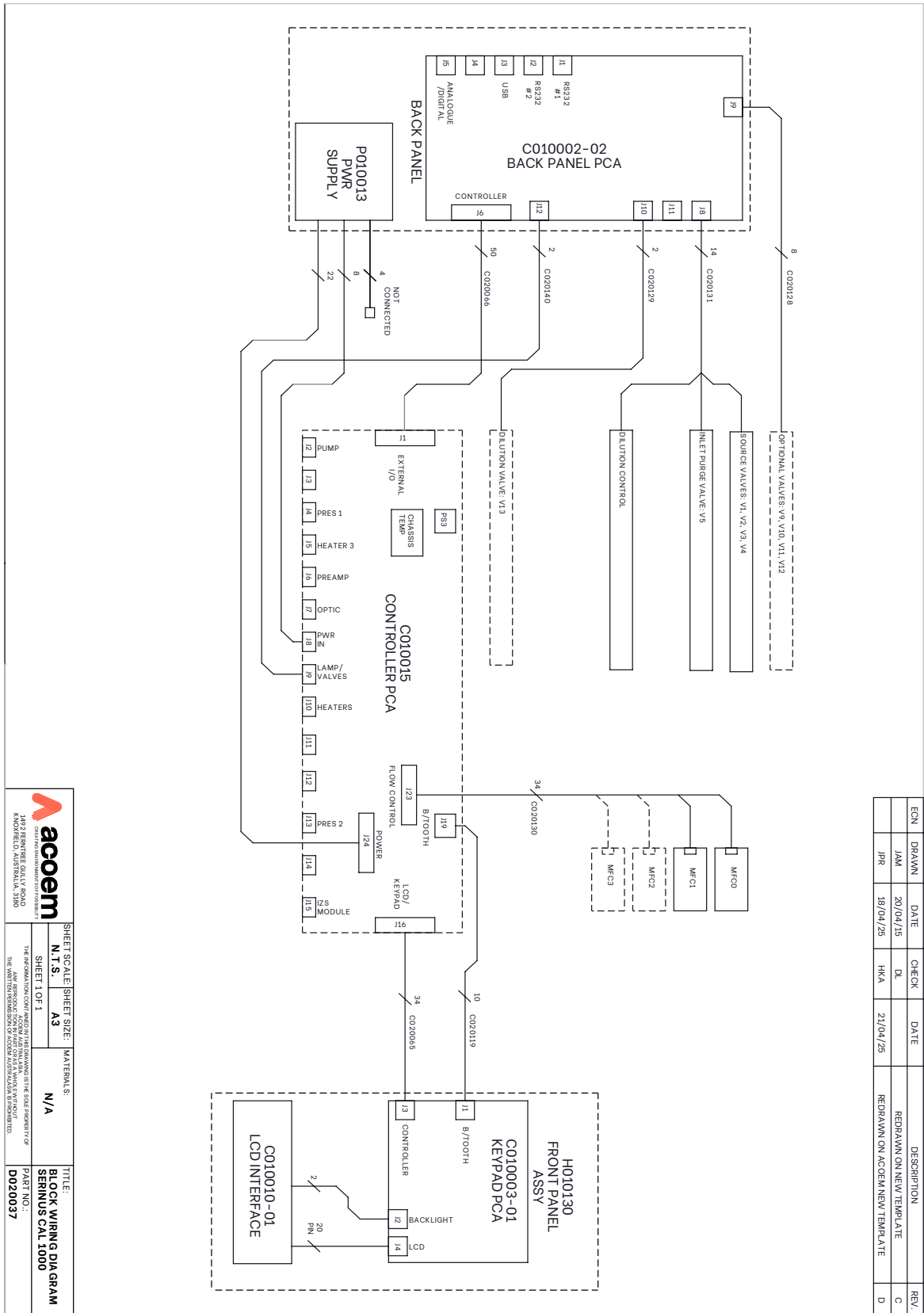

ECN	DRAWN	DATE	CHECK	DATE	DESCRIPTION	REV.
JAM	JAM	20/04/15	DL		REBRANN ON NEW TEMPLATE	C
JPR	JPR	18/04/25	HKA	21/04/25	REBRANN ON ACOEM NEW TEMPLATE	D

acoem
 1492 FERRELL GULLY ROAD
 KNOXFIELD, AUSTRALIA, 3180

SHEET SCALE: N.T.S.
 SHEET SIZE: A3
 MATERIALS: N/A

TITLE: **BLOCK WIRING DIAGRAM**
 PART NO.: **D020037**

THE INFORMATION CONTAINED IN THIS DRAWING IS THE SOLE PROPERTY OF ACOEM. ANY REPRODUCTION OR TRANSMISSION IN ANY FORM OR BY ANY MEANS WITHOUT THE WRITTEN PERMISSION OF ACOEM IS STRICTLY PROHIBITED.

9.9 Block Wiring Schematic (Serinus Cal 2000) - (PN: D020038)

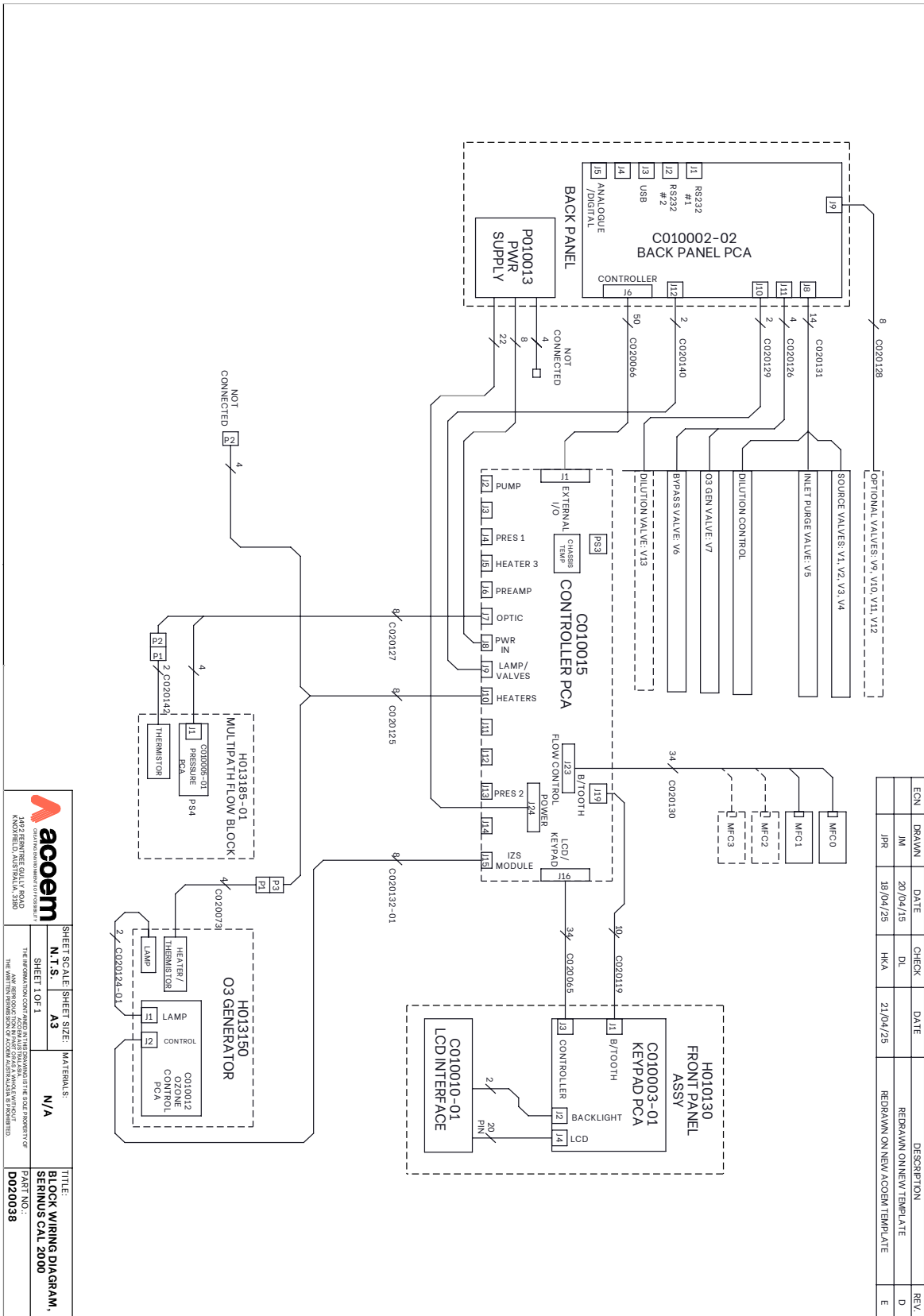

ECN	DRAWN	DATE	CHECK	DATE	DESCRIPTION	REV.
	JM	20/04/15	DL		REDRAWN ON NEW TEMPLATE	D
	JPR	19/04/25	HKA	21/04/25	REDRAWN ON NEW ACCOEM TEMPLATE	E

acoem
 QUALITY MANAGEMENT SYSTEM CERTIFIED
 1422 HERBERT GULLY ROAD
 KNOXFIELD, AUSTRALIA, 3180

SHEET SCALE:	SHEET SIZE:	MATERIALS:	TITLE:
N.T.S.	A3	N/A	BLOCK WIRING DIAGRAM, SERINUS CAL 2000
SHEET 1 OF 1			PART NO.: D020038

THE INFORMATION CONTAINED HEREIN IS THE PROPERTY OF ACCOEM AND IS TO BE USED ONLY FOR THE PURPOSES SPECIFIED. THE WARRANTIES AND CONDITIONS OF ACCOEM MATERIALS APPLY.

9.11 Valve Manifold - (PN: H013180-01)

ASSEMBLED VIEW

EC	DRAWN	DATE	CHECK	DESCRIPTION	REV.
-	BP	13/01/14		DRAWING RELEASED	A
-	BP	19/03/2014		FITTING CHANGED	B
7068	ND	20/04/2015	JM	ITEM 4 CHANGED FROM KYNAR TO S/S. EXPLODED VIEW ADDED. PLAN VIEW ROTATED BY 180° C.	C
	JM	27/08/2018	VC	FITTING CHANGED, NOW ALL STRAIGHT CONNECTORS. PORT 'NC' WAS E-BOW FITTING F039025	D

ITEM NO.	PART NUMBER	DESCRIPTION	QTY.
1	H013181	MANIFOLD, INTERNAL	1
2	H010058	VALVE, BULLET, 3 WAY 10mm SS	1
3	28100202-3	FITTING SWAGelok MALE CONNECTOR 1/8T - 1/8NPT S/S FOR GAS CAL	3

SCALE: 1:1

SHEET SIZE: A4

MATERIALS:

TITLE: MANIFOLD ASSY, INTERNAL, SS FITTINGS

PART NO: H013180-01

THE INFORMATION CONTAINED IN THIS DRAWING IS THE SOLE PROPERTY OF ECOTECH. ANY REPRODUCTION IN PART OR AS A WHOLE WITHOUT THE WRITTEN PERMISSION OF ECOTECH IS PROHIBITED.

Ecotech
1492 Ferntree Gully Road
Knoxfield, Australia, 3180

THIRD ANGLE PROJECTION

TOLERANCES UNLESS SPECIFIED:
LINEAR: XX.XX ±0.05
ANGULAR: XX°XX'±1.0'
HATCH: 1:100
MACH: FILET RAO 0.5 MAX
SURFACE: TEXTURE (V) 7.0/16

DO NOT SCALE THIS DRAWING
UNLESS OTHERWISE SPECIFIED.
DIMENSIONS ARE IN MILLIMETRES
REMOVE BURRS AND SHARP EDGES.

9.12 Mixing Manifold (Serinus Cal 3000) - (PN: H013185)

EC	DRAWN	DATE	CHECK	DATE	SHEET	DESCRIPTION	REV.
7079	JM	09/07/2015	ND			RE DRAWN	F
7154	JM	2/06/2016	WP			ADDED 4x F030032-02 & H010007 WAS F030005, F030006-01 WAS F030006, ADDED ITEM 20 & 21, REMOVED F010005 AS PER BUILD	G
7145	ND	14/09/2016	JM			REFERENCE FOR ITEM 21 WAS G.	H
7302	JM	5/07/2019	T8			FITTINGS CHANGED IN PORTS J & R, REMOVED ITEM 17 FROM PORT J	J
7358	SKS	9/05/2021	JAM	17/05/2021		FITTING UPDATED AS PER ECN	K
7398	JDP	23/05/2022	JAM	28/05/2022	1 & 3	ADDED FASTENERS & TORQUE VALUES	L

ITEM NO.	PART NUMBER	REF	DESCRIPTION	3000/ QTY.
1	H013184		MANIFOLD, INTERNAL, MULTI-PATH, KYNAR	1
2	H010058	V5, V6, V7, V8	VALVE, BULLET, 3 WAY, 10mm, SS	4
3	C010005-01		PCA, PRESSURE GAUGE, GAS ANALYZER	1
4	H010043-02	M	ORIFICE 4MIL	1
5	O010013	M, J	O-RING 5/32ID X 1/16W, VITON	2
6	H010043-04	J	ORIFICE 8 MIL	1
7	28001146-1	A, E, J, M	FITTING KYNAR MALE ELBOW 1/8" - 1/8NPT	4
8	28100202-3	F, Q	FITTING SWAGELOK MALE CONNECTOR 1/8" - 1/8NPT S/S FOR GASCAL	2
9	FIT-KQ2H07-02S	B, L	FITTING SMC MALE CONNECTOR 1/4" - 1/4BSPT	2
10	F030076		FITTING, PLUG, 3/4 BSPT, SS	1
11	F030036	C	FITTING, 1/4 BSPTO 1/8T, STRAIGHT REDUCER, SMC	1
12	H010037		GASKET, PRESSURE SENSOR	1
13	F030015	N	FITTING, PIPE PLUG 1/16 NPT, SS	1
14	S030006		THERMISTOR ASSY, ENCASMENT	1
15	F050011		M3X6 SEMS PAN HEAD PHILLIPS SCREW	1
16	F010004	M	FILTER SINTERED SS	1
17	H010062	M	SPRING COMPRESSION, 0.24 DIA 0.630 mm wire	1
18	28001143-1	1, R	FITTING, KYNAR, MALE CONNECTOR 1/8" - 1/8NPT	2
19	F030020	K	FITTING KYNAR MALE CONNECTOR 1/4" - 1/8NPT	1
20	F030201	D, H, P	FITTING MALE ELBOW WITH BARB, 1/4" - 1/8NPT	3
21	F030200	G	FITTING MALE STRAIGHT WITH BARB, 1/4" - 1/8NPT	1
22	F030032-02	D, H, O, P	FITTING KYNAR MALE ELBOW 1/4" - 1/8NPT	1
23	FAS-M3ZP-20		M3 SPRING WASHER	4
24	FAS-M3ZP-5		M3X16 PAN HEAD PHILLIPS SCREW	4

DO NOT SCALE THIS DRAWING
UNLESS OTHERWISE SPECIFIED, DIMENSIONS ARE IN MILLIMETRES
REMOVE BURRS AND SHARP EDGES.

1492 Ferntree Gully Road
Knoxfield, Australia, 3180

SCALE: 1:2
SHEET SIZE: A4
SHEET 1 OF 3

MATERIALS:
REFER BOM

TITLE:
MIXING MANIFOLD ASSY,
SERINUS CAL 3000

PART NO.: H013185

THE INFORMATION CONTAINED IN THIS DRAWING IS THE SOLE PROPERTY OF ACOEM AUSTRALASIA (ECOTECH PTY. LTD.). ANY REPRODUCTION IN PART OR AS A WHOLE WITHOUT THE WRITTEN PERMISSION OF ACOEM AUSTRALASIA IS PROHIBITED.

9.13 Mixing Manifold (Serinus Cal 2000) - (PN: H013185-01)

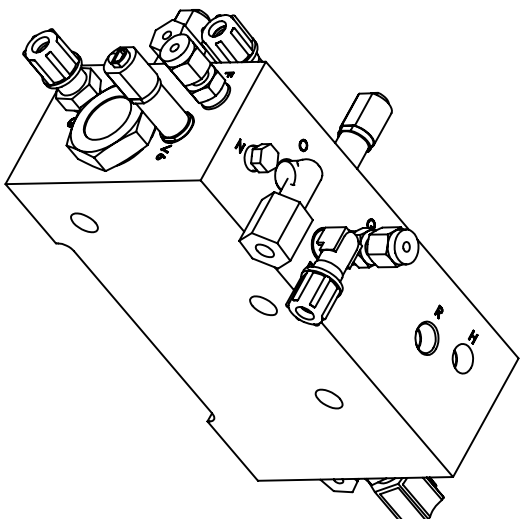
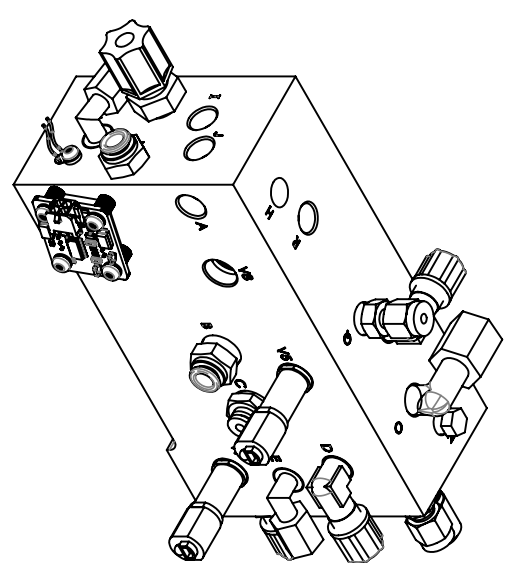



REV.	DESCRIPTION	SHEET	DATE	CHECK	DATE	DRAWN	DATE
A	DRAWING RELEASED					BP	21/05/14
B	ORFACES CHANGED			JM		BP	6/06/2014
C	PIN ADDED TO HOLD ORFACE IN PLACE					BP	14/08/2014
D	REMODELLED FOR RIVAR BLOCK, EXPLODED VIEW ADDED, SPRING ADDED TO BILL OF MATERIALS			ND		JM	26/02/2015
E	REMOVED 1x F030006, ADDED 1x F030020 & 1x H010007			ND		JM	8/02/2016
F	ADDED 3x F030032-02 & H010007 WAS F030005, F030006-01 WAS F030006, REMOVED 1x F010005, ADDED 1x F010004			WP		JM	3/06/2016
G	REMOVED 1x H010007, ADDED 1x F030020 WAS F030006-01			TB		JM	11/07/2019
H	FITTING UPDATED AS PER ECN			JAM	17/05/2021	SKS	9/05/2021
J	ADDED FASTENERS & TORQUE VALUES	2	28/05/2022	JAM		JDP	23/05/2022

NOTES:

- SEE SHEET 2 FOR EXPLODED VIEW
- SEE SHEET 2 FOR BOM

DO NOT SCALE THIS DRAWING
UNLESS OTHERWISE SPECIFIED,
DIMENSIONS ARE IN
MILLIMETRES
REMOVE BURRS AND SHARP
EDGES.



1492 Fernree Gully Road
Knookfield, Australia, 3190

SCALE: 1:2
SHEET SIZE: A4
MATERIALS: REFER BOM, SHEET 2

THE INFORMATION CONTAINED IN THIS DRAWING IS THE SOLE PROPERTY OF AIGOEM AUSTRALIA (ECONOTECH PTY. LTD.). ANY REPRODUCTION IN PART OR AS A WHOLE WITHOUT THE WRITTEN PERMISSION OF AIGOEM AUSTRALIA IS PROHIBITED.

TITLE: MANIFOLD ASSY, INTERNAL, MULTI-PATH, SERIAL
PART NO: H013185-01

ITEM NO.	PART NUMBER	DESCRIPTION	QTY
1	H013184	MANIFOLD, INTERNAL, MULTI-PATH, KYNAR	1
2	H010058	VALVE, BULLET, 3 WAY, 10mm, SS	3
3	C010005-01	PCA, PRESSURE GAUGE, GAS ANALYZER	1
4	FC95011	M3X6 SEMS PAN HEAD PHILLIPS SCREW	1
5	H010043-02	ORRICE 4MIL	1
6	O010013	O-RING, 5/32ID X 1/16W, VITON	1
6	28100202-3	FITTING, SWAGelok MALE CONNECTOR 1/8" - 1/8NPT S/S FOR GAS CAL	2
8	FF-KQ2-H07-025	FITTING, SMC, MALE CONNECTOR 1/4" - 1/8SPT	2
9	28001146-1	FITTING, KYNAR MALE ELBOW 1/8" - 1/8NPT	2
10	FC93076	FITTING, PLUG, 3/4 BSP, SS	1
11	FC93036	FITTING, 1/4 BSP TO 1/8" STRAIGHT REDUCER, SMC	1
12	H010037	GAS/KET/PRESSURE SENSOR	1
13	FC93015	FITTING, PPE PLUG 1/16 NPT SS	1
14	H010042	SPRING COMPRESSION, 0.24 DIA 0.630 mm wire	1
15	SC930006	THERMISTOR ASSY ENCASEMENT	1
16	FC93020	FITTING, KYNAR MALE CONNECTOR 1/4" - 1/8NPT	1
17	FC930032-02	FITTING, KYNAR MALE ELBOW 1/4" - 1/8NPT	1
18	FO10004	FILTER, SINTERED SS	1
19	FC93020	FITTING, MALE STRAIGHT WITH BARB, 1/4" - 1/8NPT	1
20	FC930201	FITTING, MALE ELBOW WITH BARB, 1/4" - 1/8NPT	2
21	FAS-M3ZP-5	M3X1.6 PAN HEAD PHILLIPS SCREW	4
22	FAS-M3ZP-20	M3 SPRING WASHER	4
23	H010043-09	ORRICE W/O-RING GROOVE, 10ML	1

DO NOT SCALE THIS DRAWING

UNLESS OTHERWISE SPECIFIED, DIMENSIONS ARE IN MILLIMETERS. REMOVE BURRS AND SHARP EDGES.

acoem
1492 Ferniee Gully Road
Knockfield, Australia, 3180

SCALE: 1:2
SHEET SIZE: A4
SHEET 2 OF 2

MATERIALS: REFER BOM

THE INFORMATION CONTAINED IN THIS DRAWING IS THE SOLE PROPERTY OF ACOEM AUSTRALASIA. ANY REPRODUCTION IN PART OR AS A WHOLE WITHOUT THE WRITTEN PERMISSION OF ACOEM AUSTRALASIA IS PROHIBITED.

TITLE: MIXING MANIFOLD ASSY, SERINUS CAL 2000, EXPLODED VIEW
PART NO: H013185-01

9.14 Photometer (Serinus Cal 3000) - (PN: H013100-01)

REV.	DESCRIPTION	DATE	CHECK	DATE	DRAWN	EC
D	REMOVED 1X F03020-02 & H010007. ADDED 1X 28001146-1	17/05/2021	JB	11/07/2019	JM	7202
E	FITTING 1X F03020-02 AS PER ECN 8200004. REF. ACED WITH 02002073	21/06/2022	JAM	11/07/2019	JM	7202
F	ADDED FASTENERS FOR TABLE VALUE	21/06/2022	JAM	24/05/2022	JP	7298
G	BLOCK PCB1 SCREEN. CORING CHANGED AS PER ECN 7408	16/09/2024	SKS	04/09/2024	JPR	7408
H	UPDATED DRAWING AS PER ECN 7690	12/12/2025	PIA	12/12/2025	JPR	7690

ITEM NO.	PART NUMBER	DESCRIPTION	QTY
1	H03113	REACTION CELL, TUBE FOR POLISH & ANALYTICAL ENDS	1
2	H03104	MOUNTING LOCK, LAMP AND OZONE CELL	1
3	H03107	COLLET TUBE, OZONE CELL	1
4	O00028	O-RING, 3/8"ID X .39" W. SILICONE	1
5	H03106	MOUNTING LOCK, LAMP, OZONE	2
6	O00024	O-RING, 3/8"ID X .07" W. SILICONE	2
7	H03112	GLAZETZ WINDOW 1/2"	2
8	C020077	LAMP UV, OZONE GAS ANALYZER	1
9	C020073	TERMINATOR ASSY ENCASMENT	2
10	H03101	BENCH MOUNTING OZONE CELL 1	1
11	O00006	PCAL LAMP DRIVER GAS ANALYZER	1
12	H03102	COVER TUBE, OZONE CELL	1
13	H03108	COLLET COVER, OZONE CELL	1
14	FAS-M42P-22	M4 FLAT WASHER	11
15	F050011	M3 X 8 SERINS PANHEAD PHILIPS SCREW WITH FLAT AND SPRING WASHER	5
16	FAS-M8S5-2	M3 X 4 GRUB SCREW KNURLED CUP POINT	1
17	H00007	GASLET PRESSURE SENSOR	1
18	FAS-M42P-20	M3 SPRING WASHER	5
19	O00008	O-RING, VITON	1
20	FAS-M42S-7	M4X20 PANHEAD PHILIPS SCREW	4
21	FAS-M4SS-28	M4X20 PAN HEAD PHILIPS SCREW SS	2
22	FAS-M4SS-10	M4X20 PAN HEAD PHILIPS SCREW	2
23	FAS-M42P-21	M4 SPRING WASHER	10
24	FAS-M4SS-6	SCREW M4X20 PAN HEAD PHILIPS WITH FLAT AND SPRING WASHER	2
25	H000062	SPRING COMPRESSION, 0.2430 x 0.650 mm	1
26	FAS-M8S5-4	M3X12 PAN HEAD PHILIPS SCREW	4
27	O00013	O-RING 6/320 X 1/16" WITON	2
28	O00004	PCAL PRESSURE GAUGE, GAS ANALYZER	1
29	H0004-06	GASLET PANEL	1
30	2820146-1	FITTING CYMA MALE ELONG TUB - 1/8"BT	1
31	C00007-02	PCAL TUBES FOR ISOLATED OZONE COLLET, RETAINER BLOC, O3	1
32	H03115	MOUNTING BLOCK, SENSOR AND OZONE CELL	1
33	H03114	MOUNTING BLOCK, CELL	1
34	F030098	M3 X 8 SERINS PANHEAD PHILIPS SCREW WITH FLAT AND SPRING WASHER	4
35	FAS-M4SS-15	M4X20 PANHEAD PHILIPS SCREW	3
36	H03107-01	FILTER, SILICONE W/ O-RING GROOVE	1
37	F03020-01	FERROULE, 1/4" I.D. SPLIT COMPRESSION LUBR	1
38	F03020-01	FITTING NO. 200 X 23 MM LONG	1
39	T000026	SE, 200 X 23 MM LONG	1
40	F03020-01	MALE CONNECTION, 1/4" I.D. 1/8"BT	1

DO NOT SCALE THIS DRAWING
ALL DIMENSIONS ARE IN MILLIMETERS UNLESS OTHERWISE SPECIFIED

acoem
4037 BENTLEY DRIVE, RYLAND KNOWLEDGE, AUSTRALIA, 3180

SHEET SCALE: N/A
SHEET 1 OF 2

TITLE: OPTICAL BENCH ASSY, PHOTOMETER, SERINUS CAL
PART NO.: H013100-01

9.15 Bullet Valve - (PN: H010058)

EC	DRAWN	DATE	CHECK	DATE	DESCRIPTION	REV.
7068	ND	20/04/2015	JM		INITIAL ISSUE	A
7068	ND	24/04/2015	JM		FLATS FOR FASTENING UPGRADED AND INDICATED FLATS CAN BE USED FOR FASTENING	B
	JPR	18/03/2026	SKS	18/03/2026	SHEET FORMAT CHANGED	C

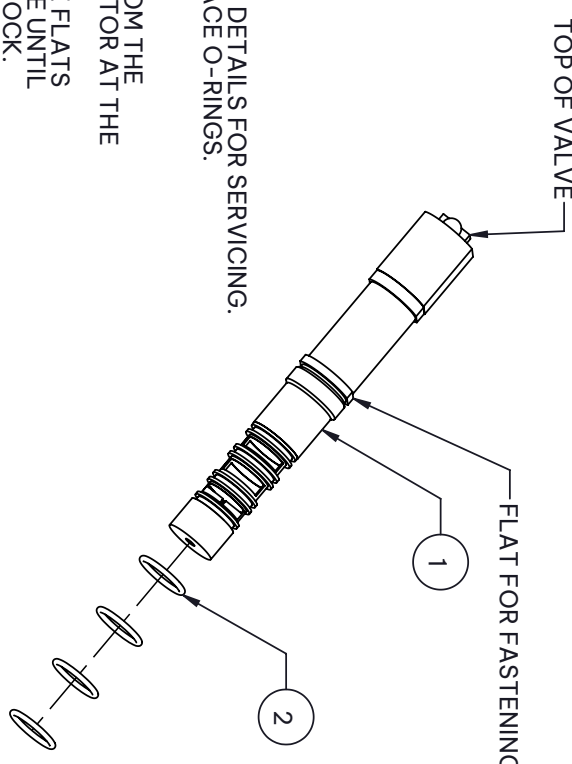

TOP OF VALVE

FLAT FOR FASTENING

1

2

NOTES:
 1. ITEM 2 SHOWS REPLACEMENT O-RING DETAILS FOR SERVICING.
 2. FOLLOW THE STEPS BELOW TO REPLACE O-RINGS.

STEPS TO REPLACE O-RINGS:

1. DISCONNECT THE POWER CABLES FROM THE VALVE BY DISENGAGING THE CONNECTOR AT THE TOP OF THE VALVE.
2. USE AN ADJUSTABLE WRENCH ON THE FLATS INDICATED TO TURN ANTI-CLOCKWISE UNTIL DISENGAGED FROM THE MAINFOLD BLOCK.
3. USE A 2mm FLAT SCREW DRIVER TO REMOVE THE 4 O-RINGS FROM AROUND THE 3 WAY VALVE.
4. REPLACE O-RINGS WITH 0010046 (ITEM 2).
5. USE THE ADJUSTABLE WRENCH TO TURN CLOCKWISE UNTIL FASTENED INTO THE BLOCK.

ITEM NO.	PART NUMBER	DESCRIPTION	QTY.
1	H010058	VALVE, BULLET, 3 WAY, 10mm, SS	1
2	O010046	O-RING, 7.5x1.0mm, VITON	4

DO NOT SCALE THIS DRAWING	 <small>CREATING ENVIRONMENTS OF POSSIBILITY</small> <small>19-21 BRENCK PARK DRIVE</small> <small>FERRIERE QUAY, VIC. AUSTRALIA, 3156</small>	<small>SHEET SCALE: SHEET SIZE:</small> N.T.S. A4	<small>MATERIALS:</small> REFER NOTES	<small>TITLE:</small> VALVE BULLET, 3 WAY, 10mm, SS
ALL DIMENSIONS ARE IN MILLIMETERS, UNLESS OTHERWISE SPECIFIED		<small>THE INFORMATION CONTAINED IN THIS DRAWING IS THE SOLE PROPERTY OF ACOEM AUSTRALIA/ASIA (CONCEPTS PTY LTD) AND BE USED WITHOUT THE WRITTEN PERMISSION OF ACOEM AUSTRALIA/ASIA IS PROHIBITED.</small>	<small>SHEET 1 OF 1</small>	<small>PART NO.:</small> H010058

This page is intentionally blank.

Appendix A. Advanced Protocol

The Advanced protocol allows access to the full list of instrument parameters.

A.1 Command Format

All commands and responses sent to and from the Instrument will be in the following packet format to ensure data is reliable.

Table 27 – Packet Format

1	2	3	4	5	6 ... 5+n	6+n	7+n
STX (2)	Serial ID	Command	ETX (3)	Message Length (n)	Message	Checksum	EOT (4)

Where:

<STX> ASCII Start of Text = 0x02 hex.

Serial ID The Serial ID assigned in the **Main Menu → Communications Menu → Serial Communication Menu.**

<ETX> ASCII End of Text = 0x03 hex.

Checksum The XOR of the individual bytes except for STX, ETX, EOT and Checksum.

Message length Must be in the range 0 to 32. Responses from the instrument can have a message Length of 0 to 255.

<EOT> ASCII End of Transmission = 0x04 hex.

Examples

A basic request for Primary gas data would be as follows:

Table 28 – Example: Primary Gas Request

Byte Number	1	2	3	4	5	6	7	8
Description	STX	ID	Command	ETX	Message Length	Primary Gas Conc	Checksum	EOT
Value	2	0	1	3	1	50	50	4
Checksum Calculation		0	$0 \oplus 1 = 1$		$1 \oplus 1 = 0$	$0 \oplus 50 = 50$	50	

And a sample response:

Table 29 – Example: Primary Gas Response

Byte Number	1	2	3	4	5	6	Continued in next table.
Description	STX	ID	Command	ETX	Message Length	Primary Gas Conc	
Value	2	0	1	3	5	50	
Checksum Calculation		0	$0 \oplus 1 = 1$		$1 \oplus 5 = 4$	$4 \oplus 50 = 54$	

Table 30 – Example: Primary Gas Response (continued)

Byte Number	7	8	9	10	11	12
Description	IEEE representation of 1.00				Checksum	EOT
Value	63	128	0	0	50	4
Checksum Calculation	$54 \oplus 63 = 9$	$9 \oplus 128 = 137$	$137 \oplus 0 = 137$	$137 \oplus 0 = 137$	137	

A.2 Commands

A.2.1 Communication Error

Where:

Command byte	0
Message byte 1	0
Message byte 2	0..7

If the command byte of a response is 0, this indicates an error has occurred. The message field will be 2 bytes long, where the 2nd byte indicates the error according to the following table.

Table 31 – List of Errors

Error #	Description
0	Bad Checksum received
1	Invalid Parameter Length
2	Invalid Parameter
3	Internal Data Flash Erase in Progress unable to return data for a few seconds
4	Unsupported Command.
5	Another process is collecting data - unable to service request.
6	MemStick No Connected
7	MemStick Busy

A.2.2 Get IEEE Value

Where:

Command byte	1
Message byte 1	Index from List of Parameters
Message byte 2..32	Additional indexes (optional)

This command requests the value of an instrument parameter. The message field byte contains the index of the parameter requested, as described in the List of Parameters.

Up to 32 indexes can be supplied in a single request. The response has 5 bytes for each parameter requested - the first byte is the parameter index and the next four are the IEEE representation of the current value.

Example

A request with a message field of 50, 51, 52 to a Serinus S40 would return a 15 byte message as shown below:

Table 32 – Example: Get IEEE Response data

1	2	3	4	5	6	7	8	9	10	11	12	13	14	15
50	NO reading				51	NOx reading				52	NO2 reading			

A.2.3 Set Calibration Mode

Where:

Command byte	4
Message byte 1	85
Message byte 2 - 5	The IEEE representation of 0, 1, 2, or 3 0 puts the instrument into Measure mode (0,0,0,0) 1 puts the instrument into Cycle mode (63,128,0,0) 2 puts the instrument into Zero mode (64,0,0,0) 3 puts the instrument into Span mode (64,64,0,0)

This command puts the instrument into a calibration mode (the same as going to the Calibration menu and choosing a Cal. Mode).

Example

A request with a command of 4 and a message field of 85,64,64,0,0 would place the instrument into Span mode.

A.2.4 Set Calibration

Enters a new calibration value: the same as entering Span Calibrate or Zero Calibrate on the calibration menu.

Where:

Command byte 18

Message byte 1 0, 1, 2, or 3 where

0 = Span

1 = Zero (first zero gas)

2 = Zero (second zero gas)

3 = Zero (Third zero gas)

Message byte 2 - 5 The IEEE representation of the calibration value.

A.2.5 Serinus Calibrator

The Serinus Cal command byte is 19. Each individual Serinus Cal operation is controlled by the first message byte (the sub-command). The corresponding byte value is indicated in parenthesis next to each sub-command name and listed as the first parameter byte value.

A.2.5.1 General Comments

All Serinus Calibrator commands use the following constants and formats.

A.2.5.1.1 Gas Index

Gasses are referred to by index. Whenever a command asks for a gas index, use the following values:

Table 33 – Gas Indexes

Gas		Index
Air	AIR	1
Ammonia	NH3	2
Butane	C4H10	3
Carbon Dioxide	CO2	4
Carbon Monoxide	CO	5
Ethane	C2H6	6
Helium	HE	7
Hydrogen Sulfide	H2S	8
Methane	CH4	9
Nitric Oxide	NO	10
Nitrogen	N2	11
Nitrogen Dioxide	NO2	12

Gas		Index
Oxygen	O2	13
Ozone	O3	14
Propane	C3H8	15
Sulfur Dioxide	SO2	16
Custom	User defined	17 - 26
Internal	Internal Air Source (if that option is installed)	27
External	External Air Source (only applies to a 3011)	28

A.2.5.1.2 Unit Index

Whenever a command asks for a unit index, use the following values:

Table 34 – Unit Indexes

Unit	Index
%	0
ppm	1
ppb	2
ppt	3

A.2.5.1.3 Port Index

Whenever a command asks for a port index, use the following values:

Table 35 – Port Indexes

Port	Index
None	0
Diluent 1	1
Diluent 2	2
Source 1	3
Source 2	4
Source 3	5
Source 4	6
Source 5	7
Source 6	8
Source 7	9
Source 8	10

A.2.5.1.4 IEEE

Any value marked IEEE is a standard IEEE 4-byte representation of a floating point value.

A.2.5.1.5 Reading and Writing Values

Refer to the Serinus Cal Parameters table for details on which values can be read and set via GetIEEEValue and SetIEEEValue.

A.2.5.2 Sub Commands

Each sub-command is detailed below.

A.2.5.2.1 Mode (1)

Sets the operational mode of the instrument. Used to start or stop points and sequences.

Table 36 – Mode Control

Parameter	Value	Byte
Sub-Command	1	1
Mode	0..3	2
Function	Varies	3*

* Conditional

The Mode is one of the following values.

0 = Stop

1 = Idle

2 = Point

3 = Sequence

Stop shuts down all operation and ignores both manual and DI input signals.

Idle stops the current point or sequence but allows manual and DI input signals.

Point runs a point. A point number between 0 and 32 must be supplied as the Function parameter; 0 is the manual point (normally a copy of the last point run).

Sequence runs a sequence. A sequence number between 1 and 16 must be supplied as the Function parameter.

A.2.5.2.2 Purge (2)

Controls the purge operation of the instrument.

Table 37 – Purge Control

Parameter	Value	Byte
Sub-Command	2	1
Operation	0..5	2
Purge Time	0..15	3*

* Conditional

The Operation is one of the following values.

0 = Stop

1 = Immediate

2 = Time

3 = Disable

4 = On Change

5 = On Start

Stop terminates a purge if one is occurring.

Immediate begins a purge immediately (the same as a manual purge).

Time is the number of seconds to do a purge. Setting this to 0 is the same as disabling the purge. The purge time value is in the Purge Time parameter (in seconds). Other modes do not accept a Purge Time parameter.

Disable stops the system from doing purges.

On Change means the system will purge when a point calls for a different gas standard.

On Start means the system will purge every time the system starts a point.

A.2.5.2.3 Port (3)

Define what standards and diluents are attached to the ports.

Table 38 – Port Definition

Parameter	Value	Byte
Sub-Command	3	1
Port Index	Port Index	2
Attachment	Gas Index or 1..10	3

The Port Index is the port to define the supply for.

Attachment is either the gas (for diluents) or the gas standard (for sources). Gas is specified by a Gas Index; the standard is numbered 1..10.

A.2.5.2.4 Standard (4)

Define a gas standard.

Table 39 – Gas Standard Definition

Parameter	Value	Byte
Command	4	1
Standard	1..10	2
Name	Text	3 - 8
Serial	Text	9 - 14
Expiry Day	1..31	15
Expiry Month	1..12	16
Expiry Year	0..63	17
Balance Gas	Gas Index	18
Gas 1	Gas Index	19
Units	Unit Index	20
Conc	IEEE	21 - 24
Gas 2*	Gas Index	25
Units*	Unit Index	26
Conc*	IEEE	27 - 30
Gas 3*	Gas Index	31
Units*	Unit Index	32
Conc*	IEEE	33 - 36
Gas 4*	Gas Index	37
Units*	Unit Index	38
Conc*	IEEE	39 - 42
Gas 5*	Gas Index	43
Units*	Unit Index	44
Conc*	IEEE	45 - 48
Gas 6*	Gas Index	49
Units*	Unit Index	50
Conc*	IEEE	51 - 54

* Optional

Standard is the index of the gas standard. Up to 10 can be defined.

Name is six ascii characters. If less than six are required, set the remaining characters to NULL (0).

Serial number is six ascii characters.

Expiry day, month, and year specify the expiry date. This has no effect on the firmware but is included for user records.

Balance Gas is the dominant gas in the standard.

Gas 1..6 are the gas names and concentrations (in ppm). Only the first gas must be defined; the rest are optional.

Units are the units the concentration value is expressed in. Thus, a standard that was 50% CO2 could be described as 4,0,50 or 4,1,500000.

Concentrations are in standard IEEE floating point format and limited to 0.0 to 100% (or 1,000,000 for ppm, etc.). Values below 0 will be clipped to 0 and above 100% will be clipped to 100%.

A.2.6 Point (5)

Define a point. Different types of points require different parameters; unused parameters should be set to zero in this command. For example, an O3 Generator point does not need a gas standard; thus, the six bytes of the Standard field should be set to 0. Refer to the Serinus Calibrator documentation to determine which fields are necessary for a given type of point.

A note on error conditions: when the user define points from the instrument menu it does not allow the user to select impossible levels of gas, Ozone, or flow, or to select gasses that are not defined in the named standard. However, during remote operation none of these checks are applied. It is up to the user to only define valid points; any invalid points will generate an error condition when they are run.

Table 40 – Point Definition

Parameter	Range	Byte
Sub-Command	5	1
Point	0..32	2
Name	Text	3 - 8
Input Mask	0xFF	9
Input Pattern	0xFF	10
Output Mask	0xFF	11
Output Pattern	0xFF	12
Operation	0..5	13
Diluent	Gas Index	14
Standard	Text	15 - 20
Gas	Gas Index	21
Units	Unit Index	22
Gas Target	IEEE	23 - 26
Units	Unit Index	27
Ozone Target	IEEE	28 - 31
Flow	IEEE	32 - 35

Point is the index of the point. 0 is the “Manual” point and 1..32 are the named points. Note that the Manual point is overwritten whenever a named point is run.

Name is six ascii characters. If less than six are required, set the remaining characters to NULL (0).

Input Mask and Pattern are bytes that set the Digital Input control signals. Each bit in Mask indicates that the following bit in Pattern is part of the signal that runs the point. If the user is not using Digital Input, set Mask and Pattern to 0.

Out Mask and Pattern are the same as the input, but control how the Digital Output lines are set. Some of these lines may be reserved by the instrument for alarms, in which case the state of the alarm will control that bit.

Operation is the type of point.

0 = Gas dilution

1 = Zero point

2 = Source Control

3 = Titration

4 = O3 Generator

5 = O3 Gen/Photometer

Diluent is a gas index.

Standard is six ascii characters. The gas standard is specified by name rather than index; at the time the point is run the instrument will search for the named standard and use it if it is attached to any port.

Gas is a gas index as defined by Table 32.

Units are the units the gas target value is expressed in.

Gas Target is the target concentration of gas in ppm.

Units are the units the Ozone target value is expressed in.

Ozone Target is the target concentration of Ozone in the above units.

Flow is the target flow in sccm.

A.2.6.1.1 Sequence (6)

Define a sequence. A sequence must contain at least one set of State/Function/Period parameters, and may contain up to sixteen. Thus the command can be as little as 16 bytes or as many as 76 bytes.

Table 41 – Sequence Definition

Parameter	Range	Byte
Sub-Command	6	1
Sequence	1..16	2
Name	Text	3 - 8

Parameter	Range	Byte
Input Mask	0xFF	9
Input Pattern	0xFF	10
Output Mask	0xFF	11
Output Pattern	0xFF	12
State*	0..3	13
Function*	1..64 or 1..16	14
Period*	0..65535	15 - 16

* May be repeated up to 15 additional times.

Sequence is the index of the sequence.

Name is six ascii characters. If less than six are required, set the remaining characters to NULL (0).

Input Mask and Pattern are bytes that set the Digital Input control signals. Each bit in Mask indicates that the following bit in Pattern is part of the signal that runs the sequence. If the user is not using Digital Input, set Mask and Pattern to 0.

Out Mask and Pattern are the same as the input, but control how the Digital Output lines are set. Some of these lines may be reserved by the instrument for alarms, in which case the state of the alarm will control that bit.

State is the action to be taken at that point in the sequence. Idle terminates the sequence; point and sequence run the sequence indicated in Function for the duration indicated in Period; and Repeat starts the sequence over at the first state.

0 = Idle

1 = Point

2 = Sequence

3 = Repeat

Function is a point or sequence index. Points range from 1..64 and sequences range from 1..16. If the State is IDLE or REPEAT then this field should be 0.

Period is the duration in minutes to run a point, or the number of times to repeat a sequence. If the State is IDLE or REPEAT then this field should be 0.

A.2.6.1.2 Ozone Cal (7)

Perform an Ozone calibration on a Serinus 2000 or 3000.

Table 42 – Ozone Calibration

Parameter	Range	Byte
Sub-Command	7	1
Calibration	0..5	2

Parameter	Range	Byte
Value*	IEEE	3 - 6

* Conditional

Calibration is one of the following operations:

Table 43 – Calibration Mode Indexes

Calibration	Value	Description
Status	0	Returns a single byte that indicates the status of the current calibration. 0 = No calibration in progress 1..10 = Current step of Automatic calibration 11 = Manual calibration is waiting to start 12 = In a manual calibration
Last	1	Returns a single byte that indicates success (1) or failure (0) of the last calibration.
Stop	2	Stop any Ozone calibration currently in progress.
Automatic	3	Begin an automatic calibration (3000 only).
Manual	4	Begin a manual calibration (2000 or 3000). The remote must follow with 5 more Ozone_Cal Value commands, supplying the Ozone concentrations at each point.
Value	5	Supplies the value measured at the current step of the manual calibration. For this command the next 4 bytes must be an IEEE float

Value is the Ozone concentration (in ppm) measured by an external instrument.

A.2.6.1.3 Manual Flow (8)

This command allows the MFCs to be directly controlled. Typically, an external program controls the MFCs, measures the flows, calculates the MFC coefficients, and then writes those results using SetIEEEValue. All of the MFCs can be controlled separately, thus allowing several MFCs to be calibrated at once.

The Manual Flow command supports four different operations: Mode, Port, Flow, and Gas.

Table 44 – Mode Selection

Parameter	Range	Byte
Sub-Command	8	1
Operation	0	2
Value	0..1	3

Mode enters or exits manual mode. While in manual flow mode all points and sequences are interrupted. While not in manual mode, all other manual flow commands are ignored.

Value is one of the following:

0 = Exit manual mode.

1 = Enter manual mode.

Table 45 – Diluent Port Selection

Parameter	Range	Byte
Sub-Command	8	1
Operation	1	2
Index	Port Index (0...3)	3

Port opens or closes a port.

Index is a port index value (see the Port Index table). Only one diluent port can be opened at a time. Setting the diluent ports to zero disables the respective MFCs. ON instruments without the optional second diluent port, selecting it has no effect.

Table 46 – Source Port Selection

Parameter	Range	Byte
Sub-Command	8	1
Operation	2	2
Index	Port Index (0, 3...10)	3

Port opens or closes a port.

Index is a port index value (see the Port Index). Only one source port can be opened at a time. Setting the source ports to zero closes all ports and disables the respective MFCs.

Table 47 – Flow

Parameter	Range	Byte
Sub-Command	8	1
Operation	3	2
MFC	1..4	3
Value	IEEE	4 - 7

Flow sets a flow for a given MFC.

NOTE: This command does not set any valves! Thus, to run flow through the optional Source MFC, the user must bypass the optional source select valve (V5) with plumbing.

MFC indicates which mass flow controller is to be set.

1 = Diluent

2 = Optional diluent

3 = Source

4 = Optional source

Value is the flow in sccm. A value of 0.0 will shut off the MFC.

Table 48 – Gas Selection

Parameter	Range	Byte
Sub-Command	8	1
Operation	4	2
Value	Gas Index	3

Gas indicates the gas being supplied for the calibration. This is only used to scale the flow values displayed on the Manual Flow Menu, so for remote calibrations it is not necessary.

Value is a Gas Index, normally AIR.

A.2.6.1.4 Gas (9)

Define a custom gas.

Table 49 – Custom Gas Definition Sub Command

Parameter	Value	Byte
Sub-Command	9	1
Index	1..10	2
Name	Text	3 - 8
Structure	1..4	9
Temperature	FLOAT	10 - 13
Density	FLOAT	14 - 17
Pure MFC	FLOAT	18 - 21

Index is the index of the custom gas. Up to 10 can be defined.

Name is six ascii characters. If less than six are required, set the remaining characters to NULL (0).

Structure is number indicating the size of the molecule.

Table 50 – Molecular Structure Index

Structure	Value
Monoatomic	1
Diatomic	2
Triatomic	3
Polyatomic	4

Temperature is the temperature constant.

Density is the density constant.

Pure MFC is the MFC fact for the gas if the bottle contained nothing but that gas.

A.3 List of Parameters

Note: Parameters in this list are for Serinus Cal series instruments and may not be applicable to other models.

All of these parameters may be logged to the USB Flash drive or requested via the GetIEEEValue command or set via the SetIEEEValue command.

Table 51 – Advanced Protocol Parameter List

#	Description	Notes
1	Cal/Zero Valve	0 = Zero, 1 = Cal
2	Internal Span Valve	0 = Off, 1 = On
3	+Analog Supply	Positive analog supply voltage
4	Gas 5 Avg.	Average of the readings (for Gas5) of the last n minutes where n is the averaging period E.g. Nx
5	Pregain	S30H linearization coefficient gain
6	Sample/Cal Valve	0 = Sample, 1 = Cal/Zero
7	NOx Measure Valve	0 = NO, 1 = NOx
8	NOx Bypass Valve	0 = NO, 1 = NOx
9	NOx Backgnd Valve	0 = Off, 1 = On
10	Valve Sequencing	0 = Off, 1 = On
11	LCD Contrast Pot	0 = Lightest, 255 = Darkest
12	SO2 Ref Zero Pot	S50 Reference zero pot
13	CO Input Pot	S30 Input pot
14	CO Reference Test Pot	Not Used
15	CO Test Measure Pot	Not Used
16	High Volt Adjust Pot	Zero
17	SO2 Lamp Adjust Pot	S50 Lamp adjustment Pot
18	O3 Lamp Adjust Pot	S10 Lamp adjustment Pot
19	O3 Meas. Zero Pot (C)	S10 Signal zero measure (coarse)
20	O3 Meas. Zero Pot (F)	S10 Signal zero measure (fine)
21	PMT Fan Pot	Optical Bench fan speed control pot
22	Rear Fan Pot	Chassis Fan speed control pot
23	Pump Fine Pot	Internal Pump speed fine pot
24	Pump Coarse Pot	Internal Pump speed coarse pot
25	Analog input 0	SO2 Reference signal
26	Analog input 1	CO Reference signal

27	Analog input 2	O3 Reference signal
28	Analog input 3	SO2 & O3 Lamp current
29	Analog input 4	Flow block pressure
30	Analog input 5	Cell pressure
31	Analog input 6	Ambient pressure
32	Analog input 7	Raw ADC calibration input
33	Analog input 8	Reserved
34	Analog input 9	Concentration data
35	Analog input 10	Reserved
36	Analog input 11	Reserved
37	Analog input 12	Raw analog to digital count for external analog input 0. 0 - 5V= 0 - 32766 A/D counts
38	Analog input 13	Raw analog to digital count for external analog input 1. 0 - 5V= 0 - 32766 A/D counts
39	Analog input 14	Raw analog to digital count for external analog input 2. 0 - 5V= 0 - 32766 A/D counts
40	Analog input 15	Reserved
41	CO Meas Zero Pot (C)	S30 Measure ZERO coarse adjustment Pot
42	CO Meas Zero Pot (F)	S30 Measure ZERO fine adjustment Pot
43	SO2 Input Pot	SO2 Measure Signal Gain Pot
44	SO2 Ref. Gain Pot	SO2 Reference Signal Gain Pot
45	SO2 Meas. Zero Pot	SO2 Measure zero pot
46	O3 Input Pot	O3 Input signal gain pot
47	Diagnostic Test Pot	The Diagnostic mode adjustment pot for all the analysers except for S30
48	NOx Input Pot	PMT signal input gain control FOR NOx
49	PGA Gain	1, 2, 4, 8, 16, 32, 64, 128
50	Gas 1 Inst.	Primary gas concentration currently displayed on the front screen E.g. NO
51	Gas 2 Inst.	Secondary gas concentration currently displayed on front screen E.g. NOx
52	Gas 3 Inst.	Calculated gas concentration currently displayed on front screen E.g. NO2
53	Gas 1 Avg.	Average of the readings (for Gas1) of the last n minutes where n is the averaging period
54	Gas 2 Avg.	Average of the readings (for Gas2) of the last n minutes where n is the averaging period
55	Gas 3 Avg.	Average of the readings (for Gas3) of the last n minutes where n is the averaging period
56	Instrument Gain	Current calibration value (default is 1.0)
57	Serial ID	Multidrop or Bayern-Hessen gas id

58	Bayern-Hessen ID	For multigas instruments only																		
59	Decimal Places	2 - 5																		
60	Noise	Instrument noise																		
61	Gas 1 Offset	An offset applied to Gas 1																		
62	Gas 3 Offset	An offset applied to Gas 3																		
63	Flow Temperature	Temperature of the flow block																		
64	Lamp Current	Lamp current in mA E.g 35mA																		
65	+5V Supply	Digital Supply voltage (should always read close to 5 volts)																		
66	Conc. Voltage	Concentration Voltage																		
67	High Voltage	High Voltage reading for PMT																		
68	Ozonator	0 = Off, 1 = On																		
69	Control Loop	0 = Off, 1 = On (default is On)																		
70	Instrument ID	XXXXXX																		
71	Gas Flow	Units in slpm																		
72	Gas Pressure	Units in torr																		
73	Ambient Pressure	Units in torr																		
74	+12V Supply	The 12 volt Power supply voltage																		
75	Cell Temperature	Cell Temperature																		
76	Conv. Temperature	Converter Temperature																		
77	Chassis Temperature	Chassis Temperature																		
78	Manifold Temp.	Temperature of the mixing manifold (all models except 1000)																		
79	Cooler Temperature	Cooler Temperature																		
80	Mirror Temperature	Mirror Temperature																		
81	Lamp Temperature	Lamp Temperature																		
82	O3 Gen. Lamp Temp.	O3 Lamp Temperature																		
83	Instrument Status	<p>Each bit in this 4-byte word represents a different condition (not all conditions apply to every instrument model):</p> <table border="1"> <thead> <tr> <th>BIT</th> <th>Condition if set</th> </tr> </thead> <tbody> <tr> <td>0</td> <td>Currently in warmup process</td> </tr> <tr> <td>1</td> <td>Volumetric units (otherwise gravimetric units)</td> </tr> <tr> <td>2</td> <td>Performing a background</td> </tr> <tr> <td>3</td> <td>Currently in Span mode</td> </tr> <tr> <td>4</td> <td>Currently in Zero mode</td> </tr> <tr> <td>5</td> <td>Instrument Out of Service (or in Diagnostic mode, PTF compensation or control loop disabled, or Comms debugging enabled)</td> </tr> <tr> <td>6</td> <td>High Voltage failure</td> </tr> <tr> <td>7</td> <td>System power failure (not actually possible to report)</td> </tr> </tbody> </table>	BIT	Condition if set	0	Currently in warmup process	1	Volumetric units (otherwise gravimetric units)	2	Performing a background	3	Currently in Span mode	4	Currently in Zero mode	5	Instrument Out of Service (or in Diagnostic mode, PTF compensation or control loop disabled, or Comms debugging enabled)	6	High Voltage failure	7	System power failure (not actually possible to report)
BIT	Condition if set																			
0	Currently in warmup process																			
1	Volumetric units (otherwise gravimetric units)																			
2	Performing a background																			
3	Currently in Span mode																			
4	Currently in Zero mode																			
5	Instrument Out of Service (or in Diagnostic mode, PTF compensation or control loop disabled, or Comms debugging enabled)																			
6	High Voltage failure																			
7	System power failure (not actually possible to report)																			

		8	Reference voltage failure
		9	Cell temperature failure
		10	Cooler failure
		11	Converter failure
		12	Correlation wheel failure
		13	Lamp source failure
		14	Flow fault
		15	Any system error (the red instrument panel light is ON)
84	Reference Voltage	Units in Volts	
85	Calibration State	This variable has two different sets of values:	
		Set Calibration State	Get IEEE Value
		0 = MEASURE	0 = MEASURE
		1 = CYCLE	1 = ZERO
		2 = ZERO	2 = SPAN
		3 = SPAN	
86	Primary Raw Conc.	(For S40, before NOx background and gain)	
87	Secondary Raw Conc.	Only for multigas instruments (For S40, before NOx background and gain)	
88	S40 Backgnd Conc.	NOx Background Concentration (For S40, before gain)	
89	Cal. Pressure	Calibration Pressure	
90	Conv. Efficiency	Converter Efficiency	
91	Multidrop Baud Rate	0 = 1200 bps 1 = 2400 bps 2 = 4800 bps 3 = 9600 bps 4 = 14400 bps 5 = 19200 bps 6 = 38400 bps	
92	Analog Range AO 0	Maximum range value for analog output	
93	Analog Range AO 1		
94	Analog Range AO 2		
95	Output Type AO 0	Output Type	
96	Output Type AO 1	1 = Voltage	
97	Output Type AO 2	0 = Current	
98	Anlg Ofst/Rng AO 0	Voltage Offset /Current Range	
99	Anlg Ofst/Rng AO 1	0 = 0% or 0 - 20mA	
100	Anlg Ofst/Rng AO 2	1 = 5% or 2 - 20mA	

		2 = 10% or 4 - 20mA
101	F/Scale Volt AO 0	5.0 Volt Calibration value
102	F/Scale Volt AO 1	
103	F/Scale Volt AO 2	
104	Z Adj Volt AO 0	0.5 Volt Calibration value
105	Z Adj Volt AO 1	
106	Z Adj Volt AO 2	
107	-Analog Supply	Negative analog supply
108	Digital Outputs	A single byte expressing the most recent state of the digital outputs
109	Digital Inputs	A single byte expressing the most recent state of the digital inputs
110	Instrument State	0 = SAMPLE FILL 1 = SAMPLE MEASURE 2 = SAMPLE FILL AUX 3 = SAMPLE MEASURE AUX 4 = SAMPLE FILL AUX2 5 = SAMPLE MEASURE AUX2 6 = BACKGROUND FILL 7 = BACKGROUND MEASURE 8 = BACKGROUND PURGE 9 = BACKGROUND FILL AUX 10 = BACKGROUND MEASURE AUX 11 = ZERO FILL 12 = ZERO MEASURE 13 = ZERO FILL AUX 14 = ZERO MEASURE AUX 15 = ZERO FILL AUX2 16 = MEASURE AUX2 17 = BACKGROUND FILL ZERO 18 = BACKGROUND MEASURE ZERO 19 = SPAN FILL 20 = SPAN MEASURE 21 = SPAN FILL AUX 22 = SPAN MEASURE AUX 23 = SPAN FILL AUX2 24 = SPAN MEASURE AUX2 25 = BACKGROUND FILL SPAN 26 = BACKGROUND MEASURE SPAN 27 = BACKGROUND PURGE SPAN 28 = ELECTRONIC ZERO ADJUST 29 = INSTRUMENT WARM UP 30 = BACKGROUND ADJUST FILL 31 = BACKGROUND ADJUST MEASURE

111	CO Lin. Factor A	CO Linearisation Factor A
112	CO Lin. Factor B	CO Linearisation Factor B
113	CO Lin. Factor C	CO Linearisation Factor C
114	CO Lin. Factor D	CO Linearisation Factor D
115	CO Lin. Factor E	CO Linearisation Factor E
116	Instrument Units	0 = ppm 1 = ppb 2 = ppt 3 = mg/m ³ 4 = µg/m ³ 5 = ng/m ³ 6 = %
117	Backgnd Meas. Time	In seconds.
118	Sample Fill Time	These parameters can be changed, but only temporarily; restarting the instrument will restore them to their default values.
119	Sample Measure Time	
120	Aux Measure Time	
121	Aux Smpl. Fill Time	
122	Backgnd Fill Time	
123	Zero Fill Time	
124	Zero Measure Time	
125	Span Fill Time	
126	Span Measure Time	
127	O3 Gen. Coeff D	O3 Generator Coefficient D
128	Backgnd Pause Time	In seconds
129	Bkgnd Intrleav Fact	
130	Cal. Pressure 2	Calibration Pressure for 2 nd gas
131	2nd Instrument Gain	Unused (always reports 1.0)
132	Background voltage	Units in Volts
133	MFC 1 Coeff A	Serial MFC coefficients MFC 1 = Diluent MFC 2 = Optional Diluent MFC 3 = Source MFC 4 = Optional Source
134	MFC 2 Coeff A	
135	MFC 3 Coeff A	
136	MFC 4 Coeff A	
137	MFC 1 Coeff B	
138	MFC 2 Coeff B	
139	MFC 3 Coeff B	
140	MFC 4 Coeff B	
141	MFC 1 Coeff C	
142	MFC 2 Coeff C	

143	MFC 3 Coeff C	
144	MFC 4 Coeff C	
145	Cycle Time	In minutes
146	CO Cooler Pot	CO Cooler voltage adjustment POT
147	CO Source Pot	CO Source voltage adjustment POT
148	CO Test Meas. Pot	Diagnostics use only
149	CO Test Ref. Pot	Diagnostics use only
150	O3 Ref Average	S10 Background Average
151	PTF Correction (gas 1)	Pressure Temperature Flow Compensation Factor for first gas
152	PTF Correction (gas 2)	Pressure Temperature Flow Compensation Factor for second gas in dual gas analysers.
153	Inst. Cell Pressure	Instantaneous cell pressure
154	Manifold Pressure	Manifold Pressure in S40 instruments
155	Cell Press. (gas 1)	Cell Pressure for Gas 1
156	Cell Press. (gas 2)	Cell Pressure for Gas 2
157	Cell Press. (Bgnd)	Cell Pressure when in Background
158	Background	0 = the instrument is measuring a gas sample 1 = the instrument is measuring background air
159	Gas To Measure	S51 only; see Measurement Settings Menu 0 = Measure both gasses 1 = Measure SO2 only 2 = Measure H2S only
160	Valve States	Diagnostic use only
161	Temperature Units	0 = "°C" 1 = "°F" 2 = "K"
162	Pressure Units	0 = "torr" 1 = "psi" 2 = "mbar" 3 = "atm" 4 = "kPa"
163	Averaging Period	0 = "1 Min" 1 = "3 Mins" 2 = "5 Mins" 3 = "10 Mins" 4 = "15 Mins" 5 = "30 Mins" 6 = "1 Hr" 7 = "4 Hrs" 8 = "8 Hrs" 9 = "12 Hrs"

		10 = "24 Hrs"
164	Filter Type	0 = NO FILTER 1 = KALMAN FILTER 2 = 10 SEC FILTER 3 = 30 SEC FILTER 4 = 60 SEC FILTER 5 = 90 SEC FILTER 6 = 300 SEC FILTER 7 = ADPTIVE FILTER
165	NO2 Filter enabled	0 = Disabled, 1 = Enabled
166	Background Interval	0 = 24 Hrs 1 = 12 Hrs 2 = 8 Hrs 3 = 6 Hrs 4 = 4 Hrs 5 = 2 Hrs 6 = Disable
167	Service (COM1) Baud	Serial baud rate
168	Multidrop (COM2) Baud	0 = 1200 bps 1 = 2400 bps 2 = 4800 bps 3 = 9600 bps 4 = 14400 bps 5 = 19200 bps 6 = 38400 bps
169	Service Protocol	0 = EC9800
170	Multidrop Protocol	1 = Bayern-Hessen 2 = Advanced 3 = Modbus
171	AO1 Over Range	The Upper Concentration Range when Over-Ranging is enabled
172	AO2 Over Range	
173	AO3 Over Range	
174	AO1 Over-Ranging	0 = Over Ranging Disabled
175	AO2 Over-Ranging	1 = Over Ranging Enabled
176	AO3 Over-Ranging	2 = Over Ranging enabled and currently active
177	Heater Set Point	Cell Heater Set Point units in °C
178	High Volt Adjust Pot	Undefined
179	PMT Test LED Pot	PMT Test LED intensity controller POT
180	Last Power Failure	Time Stamp of the Last power fail (4 byte time stamp) Bit 31:26 ---- Year (0 - 99) Bit 25:22 ---- Month (1 - 12) Bit 21:17 ---- Date (1 - 31)

		Bit 16:12 ---- Hour (00 - 23) Bit 11:06 ---- Min (00 - 59) Bit 05:00 ---- Sec (00 - 59)
181	Inst Manifold Press.	Manifold Pressure in S40 instruments (instantaneous)
182	Cell Press. (Gas 5)	Cell Pressure for Gas 5 (Nx)
183	Gas 4 <i>Inst.</i>	Calculated gas concentration currently displayed on front screen E.g. NH3
184	Gas 4 Avg.	Average of the readings (for Gas 4) of the last n minutes where n is the averaging period E.g. NH3
185	Gas 5 Inst.	Calculated gas concentration currently displayed on front screen E.g. Nx
186	NH3 Conv. Efficiency	
187	Cell/Lamp Duty Cycle	
188	Mirror T. Duty Cycle	
189	Flow Temp Duty Cycle	
190	Cooler T. Duty Cycle	
191	Conv Temp Duty Cycle	
192	CO Conv T Duty Cycle	
193	F/Scale Curr AO 0	20 mA Calibration value
194	F/Scale Curr AO 1	
195	F/Scale Curr AO 2	
196	Z Adj Curr AO 0	4 mA Calibration value
197	Z Adj Curr AO 2	
198	Z Adj Curr AO 2	
199	Ext Analog Input 0	The value of the external analog input after the multiplier and offset have been applied
200	Ext Analog Input 1	
201	Ext Analog Input 2	
202	Conv Set Point	Converter Set Point
203	Cal. Pressure 3	Calibration Pressure 3
204	PTF Correction (gas 3)	Pressure Temperature Flow Compensation Factor for third gas in multi-gas instruments.
205	Dilution Ratio	The current dilution ratio (default is 1.0)
206	Traffic Light	State of the status light: 0 = Green 1 = Amber 2 = Off (normally impossible) 3 = Red
207	Network Protocol	0 = EC9800 1 = Bayern-Hessen 2 = Advanced

		3 = Modbus
208	Gas 4 Offset	A offset applied to Gas 4
209	O3 Gen. Fine Pot	Ozone generator control, DAC controlled. DAC: 0..64535
210	O3 Gen. Lamp Current	Units in mA
211	O3 Gen. Coarse Pot	Repeat of parameter 209
212	Logging Period	The data logging period, in seconds (1.. 86400)
213	O3 Gen. Coeff A	Ozone generator coefficients
214	O3 Gen. Coeff B	Note that Coeff D is parameter 127
215	O3 Gen. Coeff C	
216	MFC 1 Voltage	Flow voltages
217	MFC 2 Voltage	Uses the same mapping as the MFC coefficients
218	MFC 3 Voltage	
219	MFC 4 Voltage	
220	Diluent Flow	SCCM
221	Source Flow	SCCM
222	Ozone Flow	SCCM
223	Output Flow	SCCM
224	Gas 1 Conc.	Delivered gas concentrations
225	Gas 2 Conc.	
226	Gas 3 Conc.	
227	Gas 4 Conc.	
228	Gas 5 Conc.	
229	Gas 6 Conc.	
230	Ozone Conc.	
231	Gas 1 Id	Gas ID number
232	Gas 2 Id	0 = AIR
233	Gas 3 Id	1 = NH3
234	Gas 4 Id	2 = C4H10
235	Gas 5 Id	3 = CO2
236	Gas 6 Id	4 = CO
237	Diluent Id	5 = C2H6
		6 = HE
		7 = H2S
		8 = CH4
		9 = NO
		10 = N2
		11 = NO2
		12 = O2
		13 = O3

		14 = C3H8 15 = SO2
238	Diluent Port	0..1
239	Source Port	0..8
240	Mode	<p>0 = Stop 1 = Idle 2 = Point 3 = Sequence 4 = Suspend 5 = Skip 6 = Rewind 7,8 = Reserved 9 = Manual</p> <p>Normally Skip and Rewind can never be read, as the instrument processes those states and leaves them instantly. Skip, Rewind, and Suspend can only be written while the system is running a sequence; otherwise, these values will be interpreted as Idle.</p> <p>Stop and Idle can be written at any time. Writing any other value (other than sequence commands during a sequence) will be interpreted as Idle.</p> <p>To start a point or sequence, use the Point or Sequence parameter. Writing point or sequence to the mode parameter will be interpreted as Idle.</p> <p>Manual is an internal state set when the instrument is operating manual flows or MFC calibrations. The reserved states are also internal states that should never appear.</p>
241	Point	<p>Current or last point (0..64), where 0 is the manual point.</p> <p>Writing this value will cause the instrument to begin running that point. An illegal point number puts the instrument into Idle.</p>
242	Sequence	<p>Current or last sequence (1..16).</p> <p>Writing this value will cause the instrument to begin running that sequence. An illegal sequence number puts the instrument into Idle.</p>
243	Operation	<p>0 = Gas Dilution 1 = Zero Point 2 = Source Control 3 = Titration 4 = O3 Generator 5 = O3 Gen/Photometer</p> <p>The current or last point operation. This value cannot be written; to change a point definition use the Serinus Calibrator commands. Note that not all operations are available on all Serinus calibrators.</p>
244	Time Remaining	Current point time remaining in minutes
245	MFC Factor Diluent	MFC factor for current diluent
246	MFC Factor Source	MFC factor for current gas standard

247	MFC 1 Size	MFC capacity in SCCM
248	MFC 2 Size	Uses the same mapping as the MFC coefficients
249	MFC 3 Size	0 means the MFC is not installed
250	MFC 4 Size	
251	Manual Timeout	Sets the manual timeout for points and flows not controlled by a sequence (0..24 hours)
252	Ozone Adjusted	Ozone value before filtering (same as 128 on a Serinus)
253	PCT Active	<p>True if the Photometer Correction Titration is enabled. This occurs after a photometer Ozone point has been running long enough to reach stability, and expires five minutes after the point stops running,</p> <p>Writing a 1 to this value will enable the PCT, so that if a titration point is launched within five minutes it will use the PCT value for the Ozone generator. To force a PCT this value must be written within five minutes before the point is started.</p>
254	PCT Value	The DAC value for the current or last photometer corrected titration point. To use this value in a titration it must be written before the point is started.

Appendix B. EC9800 Protocol

The Serinus implements a subset of the 9800-instrument protocol. Only the basic commands of reading the concentration value and setting the instrument calibration state (measure, span or zero) are supported.

B.1 Command Format

All commands are sent as ASCII strings. Fields are delimited by commas and the command ends with the normal return key (i.e. the TERMINATOR is either a <CR> or a <LF>). The DEVICE I.D. is the Serial ID assigned in the **Main Menu** → **Communications Menu** → **Serial Communication Menu**. If the instrument is not being used in a multi-drop connection, the DEVICE I.D> can be replaced with the string “???”.

B.2 Commands

B.2.1 DCONC

Function: Sends the current instantaneous concentration data to the serial port.

Format: DCONC, {<DEVICE I.D.>} {TERMINATOR}

Device response: {GAS} <SPACE> {STATUS WORD} <CR><LF>

The GAS value is the concentration value in the current instrument units, expressed as a floating point number (i.e. 12.345). The STATUS WORD indicates the instrument status in hex (i.e. A01F) using the following format:

Bit 15 = SYSFAIL (MSB)

Bit 14 = FLOWFAIL

Bit 13 = LAMPFAIL

Bit 12 = CHOPFAIL

Bit 11 = CVFAIL

Bit 10 = COOLERFAIL

Bit 9 = HEATERFAIL

Bit 8 = REFFAIL

Bit 7 = PS-FAIL

Bit 6 = HV-FAIL

Bit 5 = OUT OF SERVICE

Bit 4 = Instrument is in zero mode

Bit 3 = Instrument is in span mode

Bit 2 = Unused

Bit 1 = SET→PPM selected, CLEAR→MG/M3

Bit 0 = reserved (LSB)

B.2.2 DSPAN

Function: Commands the instrument to enter span mode.

Format: DSPAN, {<DEVICE I.D.>} {TERMINATOR}

Device response: <ACK> if the instrument is able to perform the command, <NAK> if not.

B.2.3 DZERO

Function: Commands the instrument to enter the zero mode.

Format: DZERO, {<DEVICE I.D.>} {TERMINATOR}

Device response: <ACK> if the instrument is able to perform the command, <NAK> if not.

B.2.4 ABORT

Function: Commands the instrument to abort the current span/zero mode and return to measure mode.

Format: ABORT, {<DEVICE I.D.>} {TERMINATOR}

Device response: <ACK> if the instrument is able to perform the command, <NAK> if not.

B.2.5 RESET

Function: Reboots the instrument (software reset).

Format: RESET, {<DEVICE I.D.>} {TERMINATOR}

Device response: <ACK>.

Appendix C. Bayern-Hessen Protocol

The Serinus implements a limited subset of the Bayern-Hessen Network protocol. Only the ability to set the instrument calibration state (measure, span or zero) and read the gas concentrations are supported.

C.1 Command Format

```
<STX><text><ETX>< bcc1><bcc2>
```

Where:

<STX> ASCII Start of Text = 0x02 hex.

<Text> ASCII text maximum length of 160 characters.

<ETX> ASCII End of Text = 0x03 hex.

<bcc1> ASCII representation of block check value MSB. (That is, the character “3” for 3, the character “F” for 15, etc.)

<bcc2> ASCII representation of block check value LSB.

The block check algorithm begins with 0 and exclusive-OR’s each ASCII character from <STX> to <ETX> inclusive. This block check value is converted to ASCII format and sent after the <ETX> character.

Examples

This is an example of a valid Bayern-Hessen data request for an instrument that has a Serial ID of 97 (Serial ID assigned in the **Main Menu** → **Communications Menu** → **Serial Communication Menu**):

```
<STX>DA097<EXT>3A
```

The block check calculation is best shown by the following example:

Table 52 – Bayern-Hessen Data

Character	Hex Value	Binary	Block Check
<STX>	02	0000 0010	0000 0010
D	44	0100 0100	0100 0110
A	41	0100 0001	0000 0111
0	30	0011 0000	0011 0111
9	39	0011 1001	0000 1110
7	37	0011 0111	0011 1001
<ETX>	03	0000 0011	0011 1010

The binary value 0011 1010 corresponds to the hex value 3A. This value in ASCII forms the last two characters of the data request message.

Note: The I.D. of 97 is sent as the sequence 097. All I.D. strings must have three digits and must always be padded with ASCII zero characters.

This is an example of a valid command to put the unit in the manual span mode if the instrument has an ID of 843:

<STX>ST843 K<ETX>52

The block check operation is best shown with the following table:

Table 53 – Block Check Operation

Character	Hex Value	Binary	Block Check
<STX>	02	0000 0010	0000 0010
S	53	0101 0011	0101 0001
T	54	0101 0100	0000 0101
8	38	0011 1000	0011 1101
4	34	0011 0100	0000 1001
3	33	0011 0011	0011 1010
<SPACE>	20	0010 0000	0001 1010
K	4B	0100 1011	0101 0001
<ETX>	03	0000 0011	0101 0010

The binary block check value is 0101 0010 which is the hex value 52 as shown at the end of the command string.

C.2 Commands

C.2.1 DA

Return the current instantaneous concentration.

Command Format

<STX>{DA}{<kkk>}<ETX>< bcc1><bcc2>

Where:

- kkk Device's ID. This field is optional, but if provided it must be padded with zeros to be 3 characters long. The value must match one of the following: the instrument's Bayern-Hessen ID, 000, or ??? (three question marks).
- bcc1 First byte of the block check calculation.
- bcc2 Second byte of the block check calculation.

Device response

The instrument responds with a variable length string, depending on how many measured gasses have been assigned an ID above 0. The text between the [] will be repeated once for each reported gas.

```
<STX>{MD}{cc}[<SP><kkk><SP><+nnnn+ee><SP><ss><SP><ff><SP><mmm><SP>eeeeee<SP>]<ETC><bcc1><bcc2>
```

Where:

<SP>	Space (0x20 hex).
cc	The number of gasses reported (0..5). The text in between the [] will be repeated once for each gas reported.
kkk	The Bayern-Hessen instrument ID.
+nnnn+ee	Gas concentration.
ss	Status byte (see table below for individual bits).
ff	Failure byte (see table below for individual bits).
mmm	Gas ID.
eeeeee	Acoem instrument ID (Ecotech ID in firmware).
bcc1	First byte of the block check calculation.
bcc2	Second byte of the block check calculation.

Table 54 – Status Bit Map

Status Bit	Meaning if set to 1
0	Instrument off (this value is always set to 0).
1	Out of service.
2	Zero mode.
3	Span mode.
4	-
5	-
6	Units: 1 = Volumetric, 0 = Gravimetric.
7	Background mode (S30 and S50 family only).

Table 55 – Failure Bit Map (Positive Logic)

Failure Bit	Meaning if set to 1
0	Flow sensor failure.
1	Instrument failure. Note that while the In Maintenance mode reports as an instrument failure with a red light on the front panel, for Bayern-

Failure Bit	Meaning if set to 1
	Hessen this particular error is merely a status instead of a failure.
2	-
3	Lamp failure (S40 family only).
4	-
5	Cell heater failure (S30, S40 and S50 family only).
6	-
7	-

C.2.2 ST

Set the instrument mode.

Command Format

<STX>{ST}{< kkk>}<SP>{command}<ETC><bcc1><bcc2>

Where:

kkk Device's Serial ID. This field is optional, but if provided it must be padded with zeros to be 3 characters long. The value must match one of the following: the instrument's Bayern-Hessen ID, 000, or ??? (three question marks).

Command M, N or K for Measure, Zero or Span mode.

bcc1 First byte of the block check calculation.

bcc2 Second byte of the block check calculation.

Device response

The device does not issue a response to this command.

Appendix D. ModBus Protocol

The Serinus supports a limited Modbus implementation. The only function codes supported are 3 (read holding register) and 16 (write multiple registers). The Serial ID is assigned in the **Main Menu → Communications Menu → Serial Communication Menu**.

D.1 Command Format

<Slave address><Function code><Start register (MSB)><Start register (LSB)><Register count (MSB)><Register count (LSB)><Write byte count><Write data><CRC (MSB)><CRC (LSB)>

Where:

Slave address	The instrument Serial ID. If the request is being made via TCP, this field is omitted.
Function code	3 (read) or 16 (write).
Start register	Specifies an Advanced Protocol IEEE index (refer to Table 51 to see what values are available and what index to specify for them). The ModBus index is calculated from the Advanced Protocol index via the following formula: $\text{Modbus Index} = \text{Advanced Protocol Parameter List number} \times 2 + 256$
Register count	A single read command may request from 2 to 124 registers, which is to say from 1 to 62 values. The first index is specified by Start register; all following indexes are in sequential order. To read values that are not sequential requires using another read command. Note that the number of registers must be even, as each value is returned as a floating point value (4 bytes) and each register is a word (2 bytes). A write command can only write a single IEEE value at a time. Thus, for write commands this value must be 2.
Write byte count	This field is only supplied for a write request; it indicates the amount of bytes of data that will follow, and must be set to 4 (since only one value can be written at a time).
Write data	This field is only supplied for a write request. It is the value to be written, expressed in IEEE format. The “Endian” structure can be selected on the Modbus Serial Communications menu. Big Endian means that the MSB byte of the IEEE value is at the right end of the four bytes; Little Endian means it is at the left.
CRC	Calculated by the standard Modbus CRC method. If the request is being made via TCP, this field is omitted.

D.2 Commands

D.2.1 Read Holding Registers

The response to a read request is in the following format:

<Slave address>3<Register count (MSB)><Register count (LSB)><Data><CRC (MSB)><CRC (LSB)>

Where:

Slave address	As general command format.
Register count	As general command format.
Data	4 to 248 bytes of data, representing 1 to 62 floating point numbers in IEEE format. The “Endian” structure can be selected on the Modbus Serial Communications menu. Big Endian means that the MSB byte of the IEEE value is at the right end of the four bytes; Little Endian means it is at the left.
CRC	As general command format.

D.2.2 Write Holding Register

The only supported use for this command is to set the instrument into a calibration state.

Where:

Start register MSB	1
Start register LSB	170
Register count	2
Write Data bytes	The IEEE representation of 0, 1, 2, or 3 0 puts the instrument into Measure mode (0,0,0,0) 1 puts the instrument into Cycle mode (63,128,0,0) 2 puts the instrument into Zero mode (64,0,0,0) 3 puts the instrument into Span mode (64,64,0,0)

The response to a write request is to return the first six bytes of the initiating write request.

D.2.3 Error

An error will be returned in the following format:

<Slave address><Function code><Exception code><CRC (MSB)><CRC (LSB)>

Slave address	As general command format.
Function code	The initiating command’s function code + 128; so either 131 (read) or 144 (write).
Exception code	The error code (see table below).

CRC As general command format.

Table 56 – Modbus Error Codes

Value	Error
1	Illegal Function
2	Illegal Data Address
3	Illegal Data Value
4	Slave Device Failure

This page is intentionally blank.

Appendix E. Gascal Protocol

The Serinus Cal has a number of in built serial functions that will respond when interrogated. All commands are prefixed by a digit 0..7 corresponding to the Serial ID (see **Serial Communications Menu**, Section 3.5.38). This system allows multiple Serinus Cals to be connected to and controlled by the same DTE controller.

Note: All commands are in upper case. In this list, lower-case letters are placeholders, e.g., “n” refers to a single digit number, “nn” refers to a two-digit number (preceded by 0 if necessary), “nnn” refers to an integer of any length, and “n.n” and “c0,c1,c2” refer to floating point numbers of any length.

All commands sent to the Serinus Cal must terminate with a carriage return (CR). Unless otherwise stated, all responses sent from the Serinus Cal conclude with a carriage return and line feed (CR LF).

Table 57 – Native Serial Commands

Command	Description	Response
iMFCn?	Outputs polynomial coefficients for MFC n=1..4, where result = $c2*v^2 + c1*v + c0$ 1 = Diluent 2 = Optional Diluent 3 = Source 4 = Optional Source	c0,c1,c2
iMFCn=c0,c1,c2	Inputs polynomial coefficients for MFC n=1..4 1 = Diluent 2 = Optional Diluent 3 = Source 4 = Optional Source	OK
iSETFLOWn=	Sets flow for MFC n=1..4 1 = Diluent 2 = Optional Diluent (Note: on the Gas Cal this set the flow for Ozone production; on the Serinus cal that is the same as setting the Diluent) 3 = Source 4 = Optional Source	OK
PURGE TIME?	Returns purge time in seconds	nnn
PURGE TIME=time	Sets purge time in seconds	OK
iMANUAL=ON	Turns ON Manual mode. This will begin running the last point loaded with iSETPOINT.	OK
iMANUAL=OFF	Turns off Manual mode (selects Idle mode)	OK
iT?	Outputs manual timeout (minutes)	nnn
iT=nnn	Inputs manual timeout (minutes)	OK

Command	Description	Response
iSETPOINTnn	Makes point nn the current point (i.e., loads its parameters into the Manual operation screen).	OK
iOZONE=c0,c1,c2	Sets Ozone generator coefficients	OK
iOZONE?	Returns Ozone generator coefficients	c0,c1,c2
iOZONES=n.n	Sets the current manual point's Ozone target (in ppm). For this to have any effect, iSETPOINT must have previously loaded an Ozone point.	OK
iVInn?	Outputs a/d voltage for a specific source. 0 = source MFC 1 = optional source MFC 2 = diluent MFC 3 = optional diluent MFC 4 = Ozone lamp current 5 = Ozone lamp temperature 7 = positive 12V supply 8 = positive 5V supply 10 = positive analog supply 11 = negative analog supply 13 = chassis temperature	n.n
iSTATUS?	Outputs status and any alarms	IDLE or POINTnn n, where nn is the current point and n is a bit field with the following meanings: Bit 3 = Ozone temp fail Bit 6 = source or diluent flow fail Bit 7 = bit 3 or bit 6
iVER?	Outputs software version	n.nn.nnnn
iREADn	Outputs a value based on n 0 = gas concentration of first gas in the gas standard for the current point (ppm) 1 = Ozone concentration (ppm) 2 = diluent flow (sccm) 3 = source flow (sccm)	n.n
iC?	Reports primary gas concentration (the same as iREAD0)	n.n

Appendix F. Beer-Lambert Law

The Beer-Lambert equation, shown below, is used to calculate the concentration of Ozone from the ratio of the two light intensities measured:

$$\frac{I}{I_0} = e^{-acd}$$

Equation 1 – Beer-Lambert Law

Where:

- I is the light intensity measured with Ozone in the gas sample.
- I_0 is the light intensity measured with no Ozone in the gas sample.
- a is the Ozone absorption coefficient at 253.7 nm (1.44×10^{-5} m²/mg).
- c is the mass concentration of Ozone in mg/m³.
- d is the optical path length in m.



acoem.com

User manual subject to change without notice. Images used are for illustrative purposes only.
All trademarks and registered trademarks are the property of their respective owners.
© 2026 Acoem and all related entities. All rights reserved.