

OPERATION MANUAL

MODEL 6400

Visibility Sensor

6400-9800

Rev A

12VDC



**Met One
Instruments**

POWERED BY ACOEM

Met One Instruments, Inc.

200 NE Greenfield RD.

Grants Pass, OR 97526

Telephone: (541) 471-7111

Facsimile: (541) 471-7116

metone.com



POWERED BY ACOEM

Met One Instruments, Inc. is now part of the ACOEM international group of companies.

Met One Instruments has been designing and manufacturing class-leading meteorological, ambient air sensing, and air quality monitoring instrumentation since its inception in 1989. Its line of robust industrial-grade meteorological equipment, air particulate monitoring equipment, and indoor air quality monitoring systems have set the standard for the industry. Headquartered in Grants Pass, OR, Met One Instruments, Inc. is fueled by a dedicated expert team who is diligently working to advance the technology required to ensure continued improvements in human and environmental health now and for generations to come.

Acoem is committed to helping organizations and public authorities find the right balance between progress and preservation – safeguarding businesses and assets and maximizing opportunities while conserving the planet’s resources. Headquartered in Limonest, France, Acoem delivers unrivaled inter-operable AI-powered sensors and ecosystems that empower our customers to make enlightened decisions based on accurate and timely information.

In 2021, ACOEM acquired Met One Instruments, marking a pivotal moment when two industry leaders in the air quality monitoring sectors converged – creating a single, stronger and more future-focused provider of holistic environmental monitoring solutions. Now, Met One Instruments Powered by ACOEM has opened new possibilities through an extensive offering of class leading, multi-parameter environmental monitoring and industrial reliability solutions. These integrated measurement systems, technologies, and services deliver comprehensive solutions for a range of applications, including environmental research, regulatory compliance, and industrial safety and hygiene.

For more information about Met One Instruments Powered by ACOEM, please visit: metone.com

For more information about ACOEM, please visit: acoem.com

6400 Operation Manual - © Copyright 2026 Met One Instruments, Inc. All Rights Reserved worldwide. No part of this publication may be reproduced, transmitted, transcribed, stored in a retrieval system, or translated into any other language in any form without the

Table of Contents:

1.0	Table of Figures:	4
1.1	Introduction:	6
1.2	Principle of Operation:	8
1.3	Safety Precautions:	9
1.4	Equipment List:	10
1.5	Specifications:	11
1.5.1	Visibility Sensor Model 6400.....	11
1.5.2	Optional Ambient Light Sensor (ALS):	11
1.6	Site Selection:	12
2.0	Unpacking:	13
2.1	Installation of Visibility Sensor:.....	14
2.2	Installation of the optional Ambient Light Sensor.....	14
2.3	Supply Voltage:.....	16
2.4	Communications:.....	17
2.5	Relay and Analog Output:.....	18
2.5.1	Relay and Analog Output Configuration:.....	18
2.6	Ambient Light Sensor (ALS)-optional:	19
2.6.1	ALS Configuration:.....	20
2.7	Window/Hood Heater:.....	20
2.7.1	Window/Hood Heater Configuration:.....	20
2.8	Operational Check:.....	21
3.0	Firmware Commands of the Model 6400 Visibility Sensor:	22
3.1	The FM or F? Command – Command List:	23
3.2	The F0 Command – Serial #/Firmware:	24
3.3	The F1 Command – Toggle Time Constant Averaging:.....	24
3.4	The F2 Command – LED Down Counter:.....	25
3.5	The F3 Command – New LED Down Counter:	25
3.6	The F7 Command – Toggle IR Emitter:.....	26
3.7	The F8 Command – Toggles TX Power Correction.....	26
3.8	The FA Command – A/D Converter:	27
3.9	The FB Command – Analog Configuration:	28
3.10	The FC Command – Configuration Parameters:	29
3.11	The FE Command - ALS:.....	33
3.12	The FF Command – Ambient Temperature:.....	34
3.13	The FH Command – Hood and Electronics Heaters:.....	34
3.14	The FI Command – Re-initialization:	35
3.15	The FJ Command – Pause/Resume:	35
3.16	The FK Command – Relay On/Off:	37
3.17	The FL Command – Sensor Poll:	37
3.18	The FN Command – Report Configuration:	39
3.19	The FR Command – Sensor Reset:.....	41
3.20	The FS Command - Span State Calibration:.....	41
3.21	The FT Command - Self Test:.....	42
3.22	The FU Command – Toggle Hood/Electronics Heater:.....	43
3.23	The FV Command – Toggle Window Heater:.....	44

3.24	The FW Command – Window Heater:	44
3.25	The FZ Command - Zero State Calibration:	45
3.26	The Password and Super User Privileges:	46
4.0	Maintenance of the Visibility Sensor:	47
4.1	Maintenance Schedule for the Model 6400 Visibility Sensor:	47
4.2	Fuse Location and Replacement:	48
5.0	Calibration of the Visibility Sensor:	49
6.0	Special Configuration Options:	52
6.1	Data Ready:	52
6.2	V7 Poll Response:	52
7.0	Visibility Sensor Configuration Parameter Definitions:	54
8.0	Manufacturers Information:	61

1.0 Table of Figures:

Figure 1:	Model 6400 Visibility Sensor	5
Figure 2:	Model 6300 Ambient Light Sensor	6
Figure 3:	Equipment	9
Figure 4:	Unpacking the Sensor	12
Figure 5:	Installation of Visibility Sensor	14
Figure 6:	Installation Kit	14
Figure 7:	DC Power Cable Wiring	15
Figure 8:	Communications Cable Wiring	16
Figure 9:	Analog Voltage and Relay Cable	17
Figure 10:	ALS Cable	18
Figure 11:	Message on power-up	20
Figure 12:	Result of FM or F? List of Commands	23
Figure 13:	Result of F0 Command	23
Figure 14:	Result of F1 Command	23
Figure 15:	Result of F2 Command	24
Figure 16:	Result of F3 Command	24
Figure 17:	Result of F7 Command	25
Figure 18:	Result of F8 Command	25
Figure 19:	Result of FA Command	26
Figure 20:	Result of FB Command	27
Figure 21:	Result of FC Command	29
Figure 22:	Result of FE Command	31
Figure 23:	Result of FF Command	32
Figure 24:	Result of FH Command	32
Figure 25:	Result of FJ Command	33

Figure 26: Result of FK Command	34
Figure 27: Result of FL Command.....	35
Figure 28: Result of FN Command	37
Figure 29: Result of FR Command.....	38
Figure 30: Result of FT Command.....	39
Figure 31: Result of FU Command	40
Figure 32: Result of FV Command	41
Figure 33: Window Heater Diagnostics.....	41
Figure 34: Hood Heater Warning	42
Figure 35: Result of typing “Ctrl-V” and correctly entering the Password.....	43
Figure 36: Maintenance Schedule	44
Figure 37: Fuses Function and Size.....	45
Figure 38: 92001 Calibration Plate mounting	46

1.1 Introduction:

The Model 6400 Visibility Sensor is a compact, low cost, high performance instrument used to measure the visibility in wide range of applications.

The Met One Instruments Model 6400 Visibility sensor is a low cost, high performance instrument that is used to measure visibility. This manual is designed to describe the installation, operation and maintenance of the sensor. This instrument has the ability to output visibility, extinction coefficient and proportional analog signals. A digital RS232 signal is available continuously. The analog voltage and current are proportional to a user specified range.

Visibility measurement with a forward scatter sensor requires special attention to the placement of the sensor at the installation site. The careful selection of the site is one of the critical parameters in obtaining accurate measurements. While Met One Instruments is able to offer general site selection guidelines, we assume no responsibility for poor data quality resulting from less than adequate sensor placement.

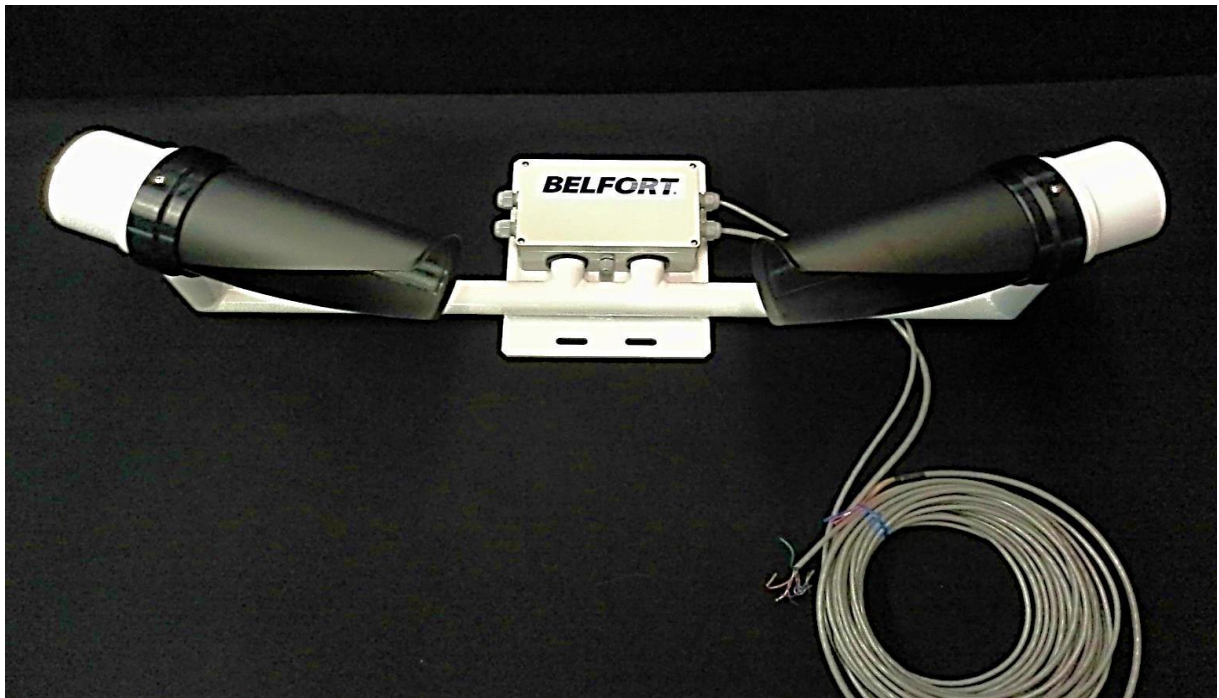

Figure 1: Model 6400 Visibility Sensor

The Model 6400 visibility Sensor can be ordered with an attached Ambient Light Sensor.

The Model 6300 Ambient Light Sensor (ALS) measures the luminance of a 6° cone of sky.

The visibility sensor powers the ALS and communicates with the ALS through a five-foot long cable.



Figure 2: Model 6300 Ambient Light Sensor

1.2 Principle of Operation:

Principles of Operation of the Met One Instruments Model 6400 Forward Scatter Visibility Sensor

The study of human vision has shown that Transmittance is the correct parameter to characterize the degradation within the specified field of vision. Transmittance is defined as the fraction of incident light at a specified wavelength that passes through the sample or in the case of the Visibility Sensors a volume of air.

(Note 1)

The Forward Scatter Visibility Sensor measures a small portion of emitted light at the specific wavelength that is scattered out of a light beam at a specified angle by the particles and aerosols within the air volume. By comparison, a Transmissometer will measure the amount of light that is not scattered out of the beam path by the particles and aerosols within the air volume.

The output value calculated by both instruments is the Extinction Coefficient. The Extinction Coefficient is the measurement of the scatter or absorption of the emitted light by the particles and aerosols within the air volume. Forward-scatter meters have a linear relationship between optical signal and extinction coefficient. Their signal output is proportional to the extinction coefficient. This Extinction Coefficient value is then used to determine the level of visibility of the air volume.

The Model 6400 is a Forward Scatter Visibility Sensor. This sensor's transmitter emits an infrared 880nm wavelength light beam from a 330 mw LED into the sample volume. The light source is modulated to provide excellent rejection of background noise and variations in background light intensity. The receiver will measure the amount of IR light that is forward scattered into the receiver by the particles and aerosols within the sample volume. The Extinction Coefficient is calculated from the amount of detected IR light at the receiver. The Visibility is then calculated from the Extinction Coefficient using the formula " $3/\text{Extco value}$ " = visibility in kilometers. This value is then converted to the desired distance measurement.

The absolute accuracy of the Model 6400 is a result of the accuracy of the visibility calibration standards. Our calibration reference standards were originally developed through extensive testing of the 6200 series instruments against NOAA NWS transmissometer at the Sterling VA facility in the late 1980s and the 6000 Reference Standards through extensive testing in 2003-2004 with the FAA for RVR applications. We have maintained factory standards since then. We have since taken advantage of every opportunity to re-verify and refine our standards for the 6200, 6000, 6500 and 6400 series of visibility instruments.

Note 1) Excerpts taken from ICAO Specification-- Manual of Runway
Visual Range Observations and Reporting Practices, Doc9328.

1.3 Safety Precautions:

Safety Precautions will be inserted in this document whenever appropriate. Warnings and Cautions are used to indicate dangerous conditions. Notes are used to highlight important steps in the procedure.

Warning

Warning notices are given when there is danger to personnel working with equipment. This is danger from high voltage. When any operation requires the removal of a cover exposing supply voltage, care must be taken to prevent contacting high voltage.

Caution

Cautions are given that could damage the equipment. The instrument contains sensitive semiconductors that could be damaged by static discharge. When handling these devices, wear a properly connected wrist strap and store devices in anti-static material.

Note

Notes are used to emphasize an essential operating or maintenance procedure, condition, or statement that must be highlighted. They pertain to proper operating conditions rather than danger to personnel or equipment.

1.4 Equipment List:

A complete Model 6400 Visibility Sensor consists of a visibility unit with its cables. There are no external enclosures required other than user supplied power and communications junction boxes.

This instrument is mounted on a single mast with an integral mounting plate and U-Bolts.

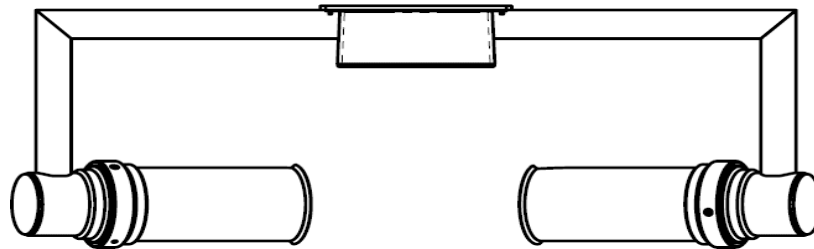

Sensor with Electronics PCB Enclosure

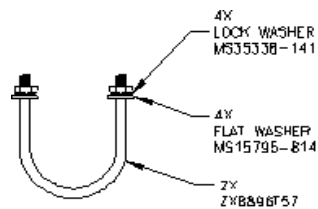
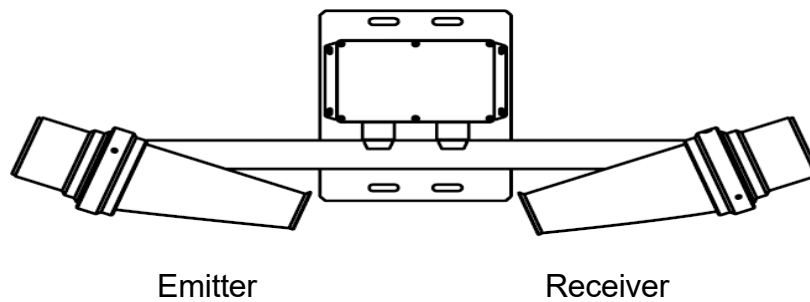

INSTALLATION KIT

FIC2-5.2j.dwg

Visibility Sensor U-Bolts

Figure 3: Equipment

1.5 Specifications:

1.5.1 Visibility Sensor Model 6400

Visibility Range	20 feet to 50 miles (6 m to 80 km)
Accuracy	+/- 10%
Scatter Angle	42° nominal
Digital I/O	RS232/485 Full Duplex, User selectable BAUD rate 300,1200,2400,4800,9600,19200,38400 BAUD), no parity, 8 data bits, one stop bit
Analog Voltage Output	0v to 1v, 0v to 5v, 0v to 10v
Analog Current Output	4 to 20 ma
Dimensions	
Visibility Sensor	38" w x 13" h x 16" d
Mast Diameter	1 1/2 to 3 1/2 inches (38 to 89mm)
Weight	17.5 lbs. (7.9 Kg)
Temperature Range Visibility Detection	-40°F to +130°F (-40°C to +55°C)
Humidity	0 to 100 % relative humidity
Power Requirements	+12 VDC +.2v -.1v at 280 ma or 3.4 Watts
With window heaters ON	Additional 550 ma or 6.6 Watts
With hood heaters and electronics heaters ON	Additional 1.66 amps or 20 watts
With ALS attached	Additional 500ma or 6 watts

1.5.2 Optional Ambient Light Sensor (ALS):

Range:	0 FL to 40,000 FL
Field of View:	6.0°
Update rate:	30 seconds.
Averaging:	30 second average.
A/D integration time:	Adapted to luminance level for optimum accuracy.
Sampling rate: integration	Maximum rate allowed by A to D time.

Accuracy: below 2	5% from 2 FL to 50,000 FL, 0.1 FL FL.
Power consumption:	6 watt at 12v DC +.5 -.1 VDC.
Diagnostics:	Hood heater and window fouling.

1.6 Site Selection:

Carefully choose the location of the instrument. Careful placement can make the difference between an accurate measurement and a measurement that does not represent the area of interest.

NOTE: General Guidelines for placement of Visibility sensor

Do not locate the instrument in low lying areas where fog tends to collect, unless this is the area of interest.

Do not locate the instrument on high rises where fog tends to blow off.

Do not locate the instrument near sources of contamination, such as smoke stacks, air vents, air conditioning units, etc.

Locate the unit at least (3 meters) away from any obstruction such as a building, radio tower, etc.

Do not install any equipment directly below the instrument.

Minimize possible interference from direct sunlight by pointing the receiver northward (southward in the southern hemisphere)

Locate the unit within 50 feet of the RS232 communications device.

2.0 Unpacking:

The Model 6400 Visibility Sensor is a precision meteorological instrument. Care has been taken to prevent damage during transit. Unpacking requires the removal of all packing materials as well as care to prevent damage during assembly and installation.

Visibility Sensor

Care should be taken in handling and removal of the instrument. There are no protective materials other than the visible packing materials used to cover the instrument. Carefully unpack the instrument.

The visibility sensor is fully assembled & factory calibrated. Store the instrument in a dry, clean environment.

It is recommended that the packing material and the shipping box be retained in case the unit should need to be returned to the factory for any reason.

The main electronics board is accessible in the electronics enclosure.

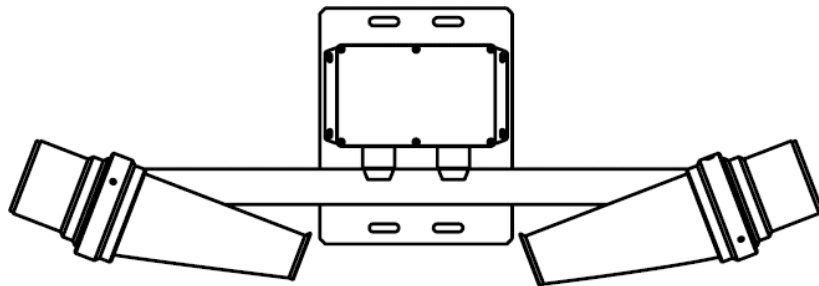

Figure 4: Unpacking the Sensor

2.1 Installation of Visibility Sensor:

The Model 6400 Visibility Sensor consists of one instrument mounted on a vertical mast with the use of two U-bolts.

Installation of the Visibility Sensor

The visibility sensor is equipped with an integral mounting plate which can be used to mount the sensor to a 1½ to 3½ inch mast or rail with U-bolts. This plate can accommodate U-Bolts with a maximum diameter of 0.35inch. The instrument should be mounted at a height that provides the best reading for the site.

NOTE: This would include but not be limited to: terrain, prevailing winds, nearby bodies of water, nearby structure(s), vegetation, local codes, blocking the view of motor vehicle operators or other factor important to the installation.

It is highly recommended that stainless steel U-bolts be used for mounting. The sensor should be mounted such that the receiver is away from other sources of light. This would include the sun, vehicles, and other optical sensors. All wiring connections use weather tight glands.

Refer to Figure 5 and 6. Position the sensor at the desired height. Place the U-bolts through the holes in the mounting plate. Place the proper nuts and washers on the U-bolt. Tighten.

Installation Kit

An Installation Kit includes two U-Bolts to mount the instrument to a vertical mast.

2.2 Installation of the optional Ambient Light Sensor

A mounting clamp is provided on the back of the ALS enclosure for mounting to a 1.5 to 2 inch diameter pole.

The ALS should be oriented to look at the northern sky 6.0° above the horizon.

Use a level indicator set the ALS to its proper mounting angle.

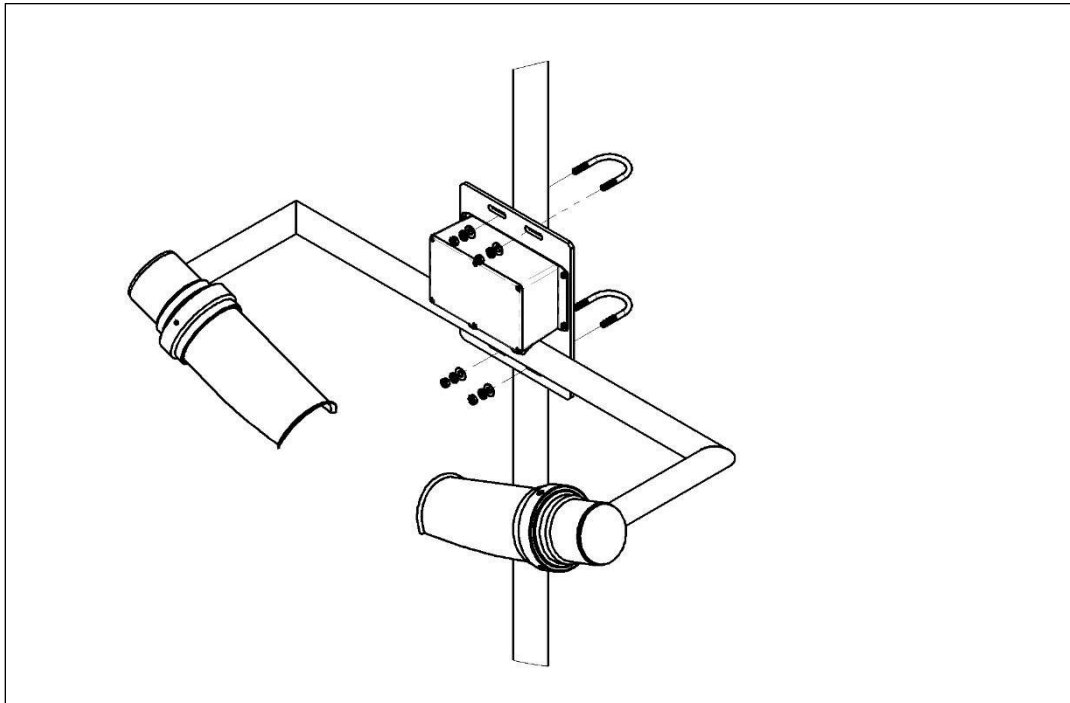
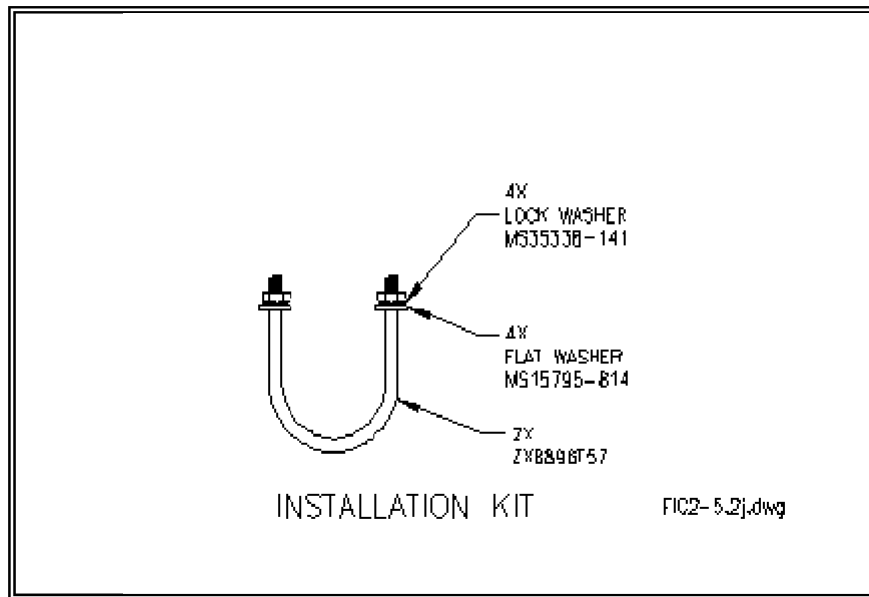

Figure 5: Installation of Visibility Sensor

Figure 6: Installation Kit



2.3 Supply Voltage:

The Model 6400 Visibility Sensor comes with attached power, communications, and analog relay cables.

The Model 6400 Visibility sensor electronics requires +12 VDC +.5 -.1 VDC at 6 watts.

The Model 6400 Visibility Heaters require +12v VDC +.5 -.1 VDC at 30 watts when on.

Note – When connecting the sensor to a DC power source, comply with all local electrical codes.

CAUTION

Do not apply main power until the instrument is fully connected to its power source and monitoring equipment.

Wiring List

Wire	From	To	Color	Signal
1	P1-1		Brown	Heater Power
2	P1-2		White	Heater Return
3	P1-3		Red	+12v Power
4	P1-4		Black	12v Return
5	P1-5		Green	Earth

Figure 7: DC Power Cable Wiring

2.4 Communications:

The Model 6400 Visibility Sensor comes with attached 25' (7.5 meter) power and communication cables.

Note: Improper connections may prevent proper communication.
Serial cable description for the Model 6400 Visibility Sensor:

Cable #64038

Wiring List

From	Color	Signal
P1-1	Red	RS232 RX
P1-2	Brown	RS232 TX
P1-3	Green	Data Ready
P1-4	Drain	RS232 Return
P1-5	Black	RS485 A
P1-6	White	RS485 B
P1-7	Blue	RS485 Y
P1-8	Orange	RS485 Z

Figure 8: Communications Cable Wiring

The instrument outputs a serial string of ASCII characters with the sensor information, status and various instrument measurements.

See the FL command for the serial output string definition.

2.5 Relay and Analog Output:

The 6400 Visibility sensor has Analog 4 to 20 ma current output, 0 to 1v, 0 to 5v or 0 to 10v voltage output ranges and a Relay form C contact. These three functions are in the same cable.

The voltage output requires configuration parameters to be set to desired ranges.

The relay output requires configuration parameters to be set to the desired visibility set points.

Cable #64043

Wiring List

Wire	From	To	Color	Signal
1	P1-1		Green	4-20 ma Out
2	P1-2		White	4-20 ma Return
3	P1-3		Blue	Analog Volt Out
4	P1-4		Drain	Analog Volt Return
5	P2-1		Black	Relay Normally Open
6	P2-2		Red	Relay Common
7	P2-3		Brown	Relay Normally Closed

Figure 9: Analog Voltage and Relay Cable

2.5.1 Relay and Analog Output Configuration:

To enable the Analog Voltage, enter Y to enable the following parameter.

Enable Analog output? (Y/N) [Disabled]

To set the voltage output to report Visibility or Visibility Extinction coefficient, enter the proper entry.

Analog output in Visibility/Exco? (V/E)[Visibility]

To set the upper Analog Visibility Clamping limit for the Analog Voltage output, enter the desired range.

Analog out limit (Vis in Mi) [10.00]

To set the upper voltage range for the Analog Voltage output, enter the desired voltage.

Output voltage range [10]

To setup the Relay operation, set the following parameters.

Fog Relay ON Delay (in minutes) [10.00]
 Fog Relay OFF Delay (in minutes) [5.00]
 Fog Threshold (vis, in Km) [16.0900]
 Fog Variability (vis, in Km) [1.6090]
 Relay Normally On (Y/N)? [No]

2.6 Ambient Light Sensor (ALS)-optional:

If there is an optional ALS attached to the Model 6400, its connection cable is shown below.

The ALS is connected at the factory. It is not field installable.

Cable #64042

Color	P2	Function
Red	5	+12v DC
Black	6	+12v Return
Orange	1	ALS_TX/6400_RX
Brown	2	ALS_TX/6400_TX
Drain	3	TX/RX Return

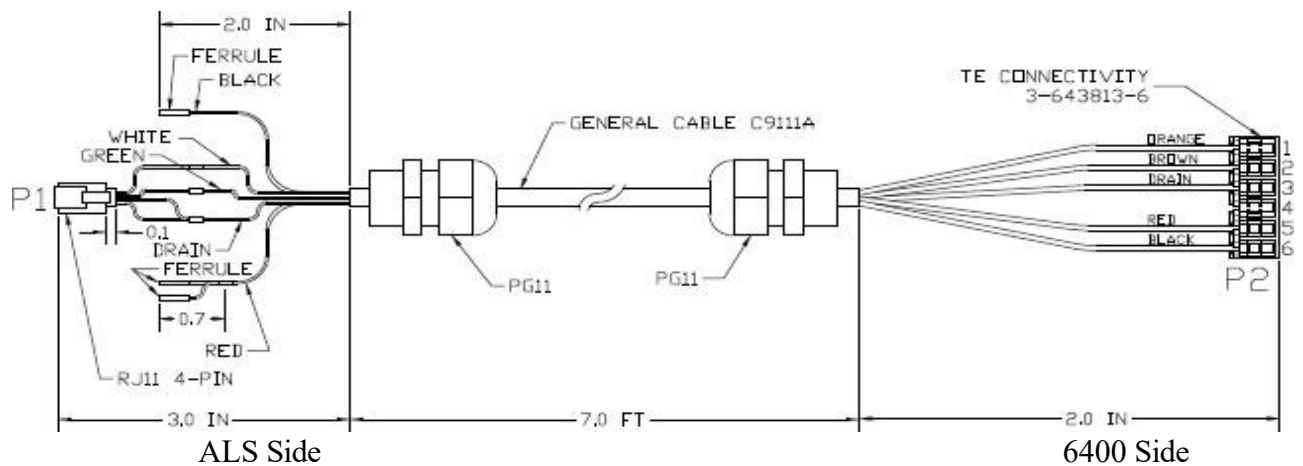

Figure 10: ALS Cable

2.6.1 ALS Configuration:

To enable the ALS operation, enter Y to enable the following configuration parameter.

Enter Y to Enable ALS (Y/N): [Disabled]

The ALS output can be reported by entering the FE command.

To enable the ALS output message appended to the Visibility output message, set the following configuration parameter.

Enter Y to append ALS message to end of the 6400 output message (Y/N):
[Disabled]

2.7 Window/Hood Heater:

WARNING

The hoods of the Visibility sensor are heated. When the temperature is below 6°C, the heaters and hoods may be uncomfortable to the touch.

2.7.1 Window/Hood Heater Configuration:

The Heater Turn ON set points for the Hood and Window heaters are configurable parameters.

The values shown below are the default values.

Enter the temperature for the Hood Heaters to turn on if temperature is below.

Hood Heater Set Point in degrees F [42.0000]

(Any Ambient Temperature below 42 deg F will cause the Hood heater to turn on.)

Enter the temperature for the Window Heaters to turn on if temperature is below.

Window Heater Set Point in degrees F [42.0000]

(Any ambient Temperature below 42 deg F will cause the Window heaters to turn on.)

Enter Y to Enable the Heater Status to be appended to the end of the FL output message.

Enable Heater Status in Serial Output (Y/N) [Disabled]

2.8 Operational Check:

The Model 6400 Visibility Sensor is an instrument that continually measures the prevailing visibility at the selected site.

The Model 6400 will automatically output data, or can be polled for data.

The digital data is accessed via the RS232 interface which is also used for the sensor configuration parameters. Refer to the section 3.0 for a description of Visibility Sensor commands.

The model 6400 Visibility Sensor must undergo an operational check before the instrument is put into service.

Connect the instrument to power source and appropriate communications equipment. Note that RS232 communication can be achieved using a PC with a terminal emulator program.

- 1) Verify the setup of the RS232 terminal to match it to the parameters specified on the Sensor nameplate. Example: 9600 BAUD, no parity, 8 data bits, 1 stop bit.
- 2) Apply power to the instrument.
- 3) This power-up message will appear on the terminal:

Belfort Instrument Model 6400 Visibility Sensor: Version 1.16 (1/4/17)

Copyright 2017 -- Belfort Instrument Company, Baltimore, MD 21224

Initializing...

Figure 11: Message on power-up

The version of firmware reported at power up may differ from the version shown here.

3.0 Firmware Commands of the Model 6400 Visibility Sensor:

The Model 6400 Visibility Sensor is controlled by an integral firmware program. The commands are available for use by the user. All commands begin with a command letter “F”. These commands control the operation of the Visibility Sensor.

All commands are in a two character format. The first character is the letter 'F', to identify this as a Visibility Sensor command and the second character selects the desired function. The Sensor's command parser is case insensitive, (e.g. 'F' is the same as 'f'), and so case doesn't matter. Each command is entered by typing only the two characters of the desired command, the ENTER key is not needed. During Sensor configuration, the ENTER key will be used.

NOTE: Set the RS232 terminal emulator to send only a carriage return for the ENTER key,
NOT carriage return / line feed.

WARNING - The calibration and performance of the instrument can be affected by operator commands via RS232. Provided with each instrument is a printout of its' configuration as it left the factory. It is highly recommended that the configuration printout be duplicated and stored for later reference in case the configuration data in the sensor is corrupted.

The following commands should **NOT** be used by the operator:

F1, F2, F3, F7, F8, F9, FI,

Note: Use of the commands listed above may erase or change calibration and/ or set up values. Improper sensor operation can result. These commands ALL require “Super-User” privileges to invoke, which is password protected (see section 3.26 about the Password).

The commands which may be used by the operator are:

F?, FM, F0 (F zero), FA*, FC*, FJ*, FK*, FL, FN, FR*, FT,

Commands marked with an asterisk ‘*’, require “Super-User” privileges to invoke, which is password protected (see section 3.26 about the Password).

3.1 The FM or F? Command – Command List:

The **FM** or **F?** commands will output a list of all of the firmware commands. See below:

The V commands shown in the list below are commands that the normal user should not use.

Table of Commands -----

f? - Get this menu.
fM - Get this menu.
f0 - Firmware revision.
f1 - Toggle "Avg_enabled" (Super User only).
f2 - Set temporary LED DownCounter (Super User only).
f3 - Store temporary LED DownCounter to EEPROM (Super User only).
f7 - Toggle the TX Enable ON/OFF (Super User only).
f8 - Toggle "TxPwrAdj" (Super User only).
Copyright 2017 -- Belfort Instrument Company, Baltimore, MD 21224
Press a key when ready...
fA - Read A/D volts (Super User only).
fB - Adjust/Clear the Analog Output DAC (Super User only).
fC - Configure the FOG Sensor (Super User only).
fE - Poll the ALS.
fF - Display Ambient Temperature in Degrees F or C.
fH - Hood and electronics heating report.
fI - Initialize EEPROM (Super User only).
fJ - Toggle data streaming ON/OFF (Super User only).
fK - Toggle the FOG relay ON/OFF (Super User only).
fL - POLL the sensor for measurement data.
fN - Show Configuration information.
fR - Reset the Sensor. (Super User only).
fS - Perform Span Calibration (Super User only).
fT - Run selftest.
fU - Take control of the Hood Heater, toggle on and off.
fV - Take control of the Window Heater, toggle on and off.
fW - Window heating report.
fZ - Perform Zero Calibration (Super User only).
Copyright 2017 -- Belfort Instrument Company, Baltimore, MD 21224
Press a key when ready...
6230A emulation commands:

v0 - Roll Call/Initialization -- Polled
v1 - Extinction Coefficient
v2 - Fixed Data Output
v7 - Poll for BMO message.
vA - "SAMOS" Output Message.
vL - Extended Output Message

vN - Extended Output Message
vT - Extended Diagnostics.
Copyright 2017 -- Belfort Instrument Company, Baltimore, MD 21224

Figure 12: Result of FM or F? List of Commands

3.2 The F0 Command – Serial #/Firmware:

The **F0** command reports the sensor's serial number and firmware revision.

The first character returned is the letter 'F' indicating that this is a Visibility Sensor. The second character is the Sensor's PASS/FAIL status. Then there is a space followed by the firmware revision. Then another space followed by the sensor's serial number. After the serial number, is a space followed by the check sum of the message in Hexadecimal.

FP v1.16 S/N:00001 E3

Figure 13: Result of F0 Command

3.3 The F1 Command – Toggle Time Constant Averaging:

Pressing the F1 key will toggle the Time constant Averaging off if currently on or on if currently off.

Time-constant averaging disabled.

Time-constant averaging enabled.

Figure 14: Result of F1 Command

3.4 The F2 Command – LED Down Counter:

The F2 command is a super User command used as part of the factory calibration of a sensor.

The F2 command should not be accessed by the normal user. Changing the LED Down Counter value will corrupt the calibration.

Enter the LED Down Counter (1-82) [60]:

Figure 15: Result of F2 Command

3.5 The F3 Command – New LED Down Counter:

The F3 command is a super User command used as part of the factory calibration of a sensor.

This command requires “Super-User” privileges to invoke, which is password protected (see section 3.26 about the Password).

The F3 command should not be accessed by the normal user. Changing the LED Down Counter value will corrupt the calibration.

New LED Down Counter = 60.
Writing settings to the EEPROM..... Done.

Figure 16: Result of F3 Command

3.6 The F7 Command – Toggle IR Emitter:

The F7 command will toggle the IR emitter from its current state.

This command requires “Super-User” privileges to invoke, which is password protected (see section 3.26 about the Password).

If the emitter is ON then the toggle will be to turn the emitter OFF. If the emitter is OFF then the toggle will be to turn the emitter ON. ON is the emitter’s normal operational state.

If the emitter is turned off, it will remain off until either it is turned back ON or the power is cycled.

TX:ON

TX:OFF

Figure 17: Result of F7 Command

3.7 The F8 Command – Toggles TX Power Correction

The command toggles between TX Power Correction enabled and disabled. TX Power Correction should always be enabled.

This command requires “Super-User” privileges to invoke, which is password protected (see section 3.26 about the Password).

TxPwrAdj Disabled

TXPwrAdj Enabled

Figure 18: Result of F8 Command

3.8 The FA Command – A/D Converter:

The **FA** command displays the voltages at each A/D converter input.

This command requires “Super-User” privileges to invoke, which is password protected (see section 3.26 about the Password).

The A/D converter channels are listed in order from 0 to 7. The voltages are expressed in units of volts. This is used for debugging purposes and may not be useful to the operator.

It should be noted that all channels may not be used in this configuration of the model 6400. The actual values will vary from the values shown below.

A/D Channel 0 volts = 0.00
A/D Channel 1 volts = 0.00
A/D Channel 2 volts = 1.96
A/D Channel 3 volts = 3.01
A/D Channel 6 volts = 2.50
A/D Channel 7 volts = 2.48

Figure 19: Result of FA Command

3.9 The FB Command – Analog Configuration:

The **FB** command will allow access to change the analog voltage and current configuration.

This command requires “Super-User” privileges to invoke, which is password protected (see section 3.26 about the Password).

It is not recommended that the customer access this command or vary the calibration of the voltage and current parameters.

Enter FB.

Response to FB command:

Enter a V to set the voltage output or an I to set the current

Response to I following FB:

Enter "L" to set the 4 mil value, "H" to set the 20 mil value or "Q" to Quit.

Response to V following FB:

Enter "L" to set the zero voltage value,
"H" to set the high voltage value or "Q" to Quit.

Response to H or L following FBI or FBV:

Please enter the data to write,
"Q" to quit, or "U" for step Up, or "D" for step Down, or "S" for Save.

Figure 20: Result of FB Command

3.10 The FC Command – Configuration Parameters:

The **FC** command allows the operator to configure the sensor. The first response is a report of the present state of the sensor's configuration. Note that this report can be obtained by itself by using the **FN** command. This is a Super User Command that requires a password.

This command requires "Super-User" privileges to invoke, which is password protected (see section 3.26 about the Password).

The values shown in the FC and FN commands are examples of the lists. Actual Values can be different from what is shown.

The FC commands outputs the full table of parameters, then repeats the table one line at a time for editing.

FOG Sensor Configuration:

Sensor Serial Number:	00001
Enable Secondary ID (Y/N)?	[Disabled]
Secondary ID	[65 = 'A']
Update Rate (in seconds)	[1]
Enable Polled Mode (Y/N)?	[Disabled]
Calibration Zero	[0.00000]
Calibration Span	[1.00000]
Tx Power Detect Calibration	[8000.0000]
Tx LED Down-Counter	[60]
Time Constant (in seconds)	[57]
Fog Relay ON Delay (in minutes)	[10.00]
Fog Relay OFF Delay (in minutes)	[5.00]
Fog Threshold (vis, in Km)	[16.0935]
Fog Variability (vis, in Km)	[1.6093]
Sensor Serial Number	[1]
Sensor Baud Rate	[9600]
Visibility Units	[kilometers]
Calibration ExtCo	[1208.9875]
Relay Normally On (Y/N)?	[No]
Enable Verbose Mode (Y/N)?	[Disabled]
Enable Time-Constant Averaging (Y/N)?	[Enabled]
Enable Visibility Clamping (Y/N)?	[Enabled]
Visibility Range Limit (in Km)	[48.2804]
Enable Tx Power Correction (Y/N)?	[Enabled]
Enable Short Message (Y/N)?	[Disabled]
Wavelength Correction Factor	[0.0000]
Wavelength Correction Exponent	[0.0000]
Enable 6000 Response Format (Y/N)?	[Disabled]
Enable 6230A Emulation (Y/N)?	[Disabled]

6230A Emulation Message Type

[Normal]

BMO Type ID	[0]
Enable RTS Before Transmit (Y/N)?	[Enabled]
RTS Delay Before Transmit (in ms)	[4]
Enable 'V7' Poll Response (Y/N)?	[Disabled]
SetRS232? (Y/N)	[Enabled]
Enter Y to Enable ALS (Y/N):	[Enabled]
Enter Y to append ALS message to end of the 6400 output message (Y/N):	[Disabled]
Enable Analog output? (Y/N)	[Disabled]
Analog output in Visibility/Exco? (V/E)	[Visibility]
Analog out limit (Vis in Km)	[16.09]
Output voltage range	[10]
Report Ambient Temp (Y/N)	[Enabled]
Temperature Units in degrees C (Y/N)	[Disabled]
Hood Heater Set Point in degrees F	[42.0000]
Window Heater Set Point in degrees F	[42.0000]
Minimum total window heater resistance	[15.4000]
Maximum total window heater resistance	[24.0000]
Minimum Collector hood heater resistance	[6.7000]
Maximum Collector hood heater resistance	[10.5000]
Minimum Base hood heater resistance	[7.9000]
Maximum Base hood heater resistance	[12.3000]
Enable Heater Status in Serial Output (Y/N)	[Disabled]

Figure 21: Result of FC Command

After the configuration status report, the operator will be prompted for any changes to each configuration parameter. If the operator does not wish to change a specific parameter, just press ENTER to skip to the next one. To backup one line in the parameter list, enter the ^ key or the backspace key. If the desired parameter has been passed over by accident, press ESC, and start the **FC** command over again. After typing the new value of the desired parameter, press ENTER to save it, or press ESC to abort this entry and quit the configuration function. It is also possible to avoid traversing the entire list after changing only one (or more) parameters by pressing ESC **AFTER** saving the last changed parameter (save by pressing ENTER when typing the new value).

Sensor Serial Number: 00157

Type in a new value for each item, or "ENTER" to leave it alone.

Enable Secondary ID (Y/N)?	[Disabled]
Secondary ID	[65 = 'A']
Update Rate (in seconds)	[1]
Enable Polled Mode (Y/N)?	[Disabled]
Calibration Zero	[0.00084]

Calibration Span	[3.41191]
Tx Power Detect Calibration	[38.4240]
Tx LED Down-Counter	[60]
Time Constant (in seconds)	[57]
Fog Relay ON Delay (in minutes)	[10.00]
Fog Relay OFF Delay (in minutes)	[5.00]
Fog Threshold (vis, in Km)	[16.0900]
Fog Variability (vis, in Km)	[1.6090]
Sensor Serial Number	[157]
Sensor Baud Rate	[9600]
Visibility Units	[kilometers]
Calibration ExtCo	[246.0000]
Relay Normally On (Y/N)?	[No]
Enable Verbose Mode (Y/N)?	[Disabled]
Enable Time-Constant Averaging (Y/N)?	[Enabled]
Enable Visibility Clamping (Y/N)?	[Enabled]
Visibility Range Limit (in Km)	[50.0000]
Enable Tx Power Correction (Y/N)?	[Enabled]
Enable Short Message (Y/N)?	[Disabled]
Wavelength Correction Factor	[0.0000]
Wavelength Correction Exponent	[0.0000]
Enable 6000 Response Format (Y/N)?	[Disabled]
Enable 6230A Emulation (Y/N)?	[Disabled]
6230A Emulation Message Type	[Normal]
BMO Type ID	[0]
Enable RTS Before Transmit (Y/N)?	[Disabled]
RTS Delay Before Transmit (in ms)	[4]
Enable 'V7' Poll Response (Y/N)?	[Disabled]
SetRS232? (Y/N)	[Enabled]
Enter Y to Enable ALS (Y/N):	[Disabled]
Enter Y to append ALS message to end of the 6400 output message (Y/N):	[Disabled]
Enable Analog output? (Y/N)	[Disabled]
Analog output in Visibility/Exco? (V/E)	[Visibility]
Analog out limit (Vis in Mi)	[10.00]
Output voltage range	[10]
Report Ambient Temp (Y/N)	[Disabled]
Temperature Units in degrees C (Y/N)	[Disabled]
Hood Heater Set Point in degrees F	[43.0000]
Window Heater Set Point in degrees F	[130.0000]
Minimum total window heater resistance	[15.4000]
Maximum total window heater resistance	[24.0000]
Minimum Collector hood heater resistance	[6.7000]
Maximum Collector hood heater resistance	[10.5000]
Minimum Base hood heater resistance	[7.9000]
Maximum Base hood heater resistance	[12.3000]

Enable Heater Status in Serial Output (Y/N)[Disabled]

After leaving the data entry portion of configuration, the configuration status report will be shown with the updated values.

3.11 The FE Command - ALS:

If the optional ALS is connected to the Visibility Sensor, the **FE** command reports the Ambient Light Sensor's values.

The Model 6400 Visibility Sensor can have a Model 6300 Ambient Light Sensor attached. The visibility sensor will retrieve the ALS values from the ALS sensor and hold them in its volatile memory.

When the FE command is received by the visibility sensor, it will report the last values received from the ALS.

06.13254665,0.001322434,80

Figure 22: Result of FE Command

The format of the ALS message is XXXXXXXXXXXX,XXXXXXXXXXXX,XX. As shown, the ALS message consists of three numbers separated by commas. The first two numbers are in floating point format and the third number is a two-digit integer.

The first number is the measured sky luminance. The measurement value is in units of foot-lambert.

The second number is the window-fouling value. A window-fouling value higher than 0.05 indicated that the ALS window should be cleaned to ensure that the luminance measurement remains within specified accuracy. Excessive fouling of the ALS window may cause the luminance reading to be unacceptably low.

The third number is the ALS window/hood heater status. The two-digit heater status is either 00 or 80. A heater status of 80 indicates proper ALS window/hood heater operation. An ALS window/hood heater status of 00 indicates that the window/hood heater is defective.

If there is no ALS attached, the result of FE command will be an N/A in place of the value message.

If there is an ALS attached and its first internal value averaging time period is not completed, the response to the FE command will be all 0's in the three ALS message fields: 00000000000,00000000000,00.

As soon as the averaging time period is over, the ALS will output the proper values.

3.12 The FF Command – Ambient Temperature:

Entering the FF command will cause the sensor to measure and report the Ambient Temperature.

The temperature measurement requires 1 minute of measurements. If the temperature command is issued before the 1 minute average time has completed, the temperature will be reported as not available.

Ambient Temperature = 65.8 Degrees F

Figure 23: Result of FF Command

3.13 The FH Command – Hood and Electronics Heaters:

Entering the FH command will cause the sensor to test and report the operational status of the Hood and Electronics heaters. The diagnostics report the hood and electronics heater current and heater wattage. The Window Heater output message is as follows:

Heater Power DC volts: 11.80
Heater Power RMS volts: 11.80

Hood and Electronics Heating:

Unit	DC amps	RMS amps	Watts	Ohms
Transmitter	1.25	1.25	14.7	9.4
Receiver	1.39	1.39	16.3	8.5

Figure 24: Result of FH Command

3.14 The FI Command – Re-initialization:

The FI command will re-initialize the configuration in the instrument non-volatile memory to factory default values. All calibration and user specific configuration parameters will be lost.

The user should NOT execute this command.

3.15 The FJ Command – Pause/Resume:

The **FJ** command Enables or Disables the **Polled mode** configuration parameter. This allows the operator to quickly stop RS-232 data output if needed without changing the EEPROM. This is a Super User Command that requires a password.

This command requires “Super-User” privileges to invoke, which is password protected (see section 3.26 about the Password).

This command does not modify the value of the **Polled mode** parameter in EEPROM. The value of the **Polled mode** parameter will return to its’ normal state if the sensor is rebooted or if either the **FC**, or **FN** command are used.

The FJ command will act as a pause / resume function. The data stream is stopped with the first FJ command. If the FJ command is given again, the instrument will begin to send data.

```
P,00001, 0, 44.48614120, 20.64200163, 0.00550,Mi, 338.99693
```

Stopped sending data.

(No data sent)

Start to send data.

```
P,00001, 0, 44.48685646, 20.64457178, 0.00550,Mi, 338.99109
```

```
P,00001, 0, 44.48516846, 20.64327717, 0.00550,Mi, 338.99391
```

```
P,00001, 0, 44.48614120, 20.64200163, 0.00550,Mi, 338.99693
```

```
P,00001, 0, 44.48498726, 20.64074516, 0.00550,Mi, 338.99970,UNR
```

```
P,00001, 0, 44.48498726, 20.64074516, 0.00550,Mi, 338.99970,OVR
```

Figure 25: Result of FJ Command

3.16 The FK Command – Relay On/Off:

The **FK** command allows the operator to manually switch the relay ON and OFF for testing. This is a Super User Command that requires a password.

This command requires “Super-User” privileges to invoke, which is password protected (see section 3.26 about the Password).

This command “toggles” the state of the relay. If the relay is ON, the **FK** command will turn it OFF. If the relay is OFF, the **FK** command will turn it ON. The effect of this command lasts for only 5 seconds. When 5 seconds have passed since the **FK** command was entered, the relay will return to normal functioning.

Relay: ON
Relay: OFF

Figure 26: Result of FK Command

3.17 The FL Command – Sensor Poll:

The **FL** command is used to Poll the Sensor for measurement data. This command works whether or not "Polled mode" is enabled. If "Polled mode" is disabled, the Sensor will send measurement data automatically at time intervals specified by the "update_rate". "Polled mode" can be enabled or disabled and "update_rate" can be changed via the **FC** command.

Note that "update_rate" can be set to a maximum of 255 seconds.

P,00001,	0,	44.48685646,	20.64457178,	0.00550,Mi,	338.99109									
P,00001,	0,	44.48685646,	20.64457178,	0.00550,Mi,	338.99109									
P,00001,	0,	44.48685646,	20.64457178,	0.00550,Mi,	338.99109,UNR									
P,00001,	0,	44.48685646,	20.64457178,	0.00550,Mi,	338.99109,000...00,000...000,80,1010,OVR,									
^	^	^	^	^	^	^	^	^	^	^	^	^	^	^
A	B	C	D	E	F	G	H	I	J	K	L	M		

Figure 27: Result of FL Command

The data returned by the **FL** command is delimited by commas to facilitate importing the data into a spreadsheet or data base. The 9 columns of data are identified by letters above, and are described by letter below.

- (A) Sensor status, PASS = 'P', FAIL='F'.
- (B) Sensor serial number.
- (C) FOG Relay state, 0 = OFF, 1 = ON (Status).
- (D) Received Signal - % of full scale.
- (E) Transmitter Power Detect value (Not used by operator) - % of full scale.
- (F) Visibility in units specified in the configuration data.
- (G) Visibility units.
- (H) Extinction Coefficient (ExtCo) in units of Km^{-1} .
- (I) ALS Ambient Light Value in foot-lamberts. If enabled.
- (J) ALS Window Fouling value. If enabled.
- (K) ALS Heater Status. If enabled.
- (L) Visibility Sensor Heaters Status. If enabled.
- (M) Over-range (OVR), Under-range (UNR) warning.

The Sensor may occasionally report OVR or UNR at very high or low visible levels. Neither of these indications should be cause for alarm unless the Sensor NEVER shows a normal report. If neither condition exists, the field will be empty. (The 3 *'s are to indicate 3 characters field size).

There are several configuration parameters that will enable additional information to be appended to the end of the FL command serial response.

To add the ALS message to the serial string, set the following parameter to Y for Enable.

Enter Y to append ALS message to end of the 6400 output message
(Y/N):[Disabled]

To add the Window and Hood heater status to the serial string, set the following parameter to Y for Enable.

Enable Heater Status in Serial Output (Y/N) [Disabled]

1010,

The last field is the heater status. It consists of 4 digits, each a 0 or 1.

The first digit is 0 if the hood heaters are turned off and 1 if the hood heaters are turned on.

The second digit is not used.

The third digit is 0 if the window heaters are turned off and 1 if the window heaters are turned on.

The fourth digit is not used.

3.18 The FN Command – Report Configuration:

The **FN** command allows the operator to view the present state of the sensor's configuration.

The values shown in the FC and FN commands are examples of the lists. Actual Values can be different from what is shown. The configuration can be changed with the **FC** command.

FOG Sensor Configuration:

Sensor Serial Number:	00001
Enable Secondary ID (Y/N)?	[Disabled]
Secondary ID	[65 = 'A']
Update Rate (in seconds)	[1]
Enable Polled Mode (Y/N)?	[Disabled]
Calibration Zero	[0.00000]
Calibration Span	[1.00000]
Tx Power Detect Calibration	[8000.0000]
Tx LED Down-Counter	[60]
Time Constant (in seconds)	[57]
Fog Relay ON Delay (in minutes)	[10.00]
Fog Relay OFF Delay (in minutes)	[5.00]
Fog Threshold (vis, in Km)	[16.0935]
Fog Variability (vis, in Km)	[1.6093]
Sensor Serial Number	[1]
Sensor Baud Rate	[9600]
Visibility Units	[kilometers]
Calibration ExtCo	[1208.9875]
Relay Normally On (Y/N)?	[No]
Enable Verbose Mode (Y/N)?	[Disabled]
Enable Time-Constant Averaging (Y/N)?	[Enabled]
Enable Visibility Clamping (Y/N)?	[Enabled]
Visibility Range Limit (in Km)	[48.2804]
Enable Tx Power Correction (Y/N)?	[Enabled]
Enable Short Message (Y/N)?	[Disabled]
Wavelength Correction Factor	[0.0000]

Wavelength Correction Exponent [0.0000]
 Enable 6000 Response Format (Y/N)? [Disabled]
 Enable 6230A Emulation (Y/N)? [Disabled]
 6230A Emulation Message Type [Normal]
 BMO Type ID [0]
 Enable RTS Before Transmit (Y/N)? [Enabled]
 RTS Delay Before Transmit (in ms) [4]
 Enable 'V7' Poll Response (Y/N)? [Disabled]
 SetRS232? (Y/N) [Enabled]
 Enter Y to Enable ALS (Y/N): [Enabled]
 Enter Y to append ALS message to end of the 6400 output message
 (Y/N):[Disabled]

Enable Analog output? (Y/N) [Disabled]
 Analog output in Visibility/Exco? (V/E)[Visibility]
 Analog out limit (Vis in Km) [16.09]
 Output voltage range [10]
 Report Ambient Temp (Y/N) [Enabled]
 Temperature Units in degrees C (Y/N) [Disabled]
 Hood Heater Set Point in degrees F [42.0000]
 Window Heater Set Point in degrees F [42.0000]
 Minimum total window heater resistance [15.4000]
 Maximum total window heater resistance [24.0000]
 Minimum Collector hood heater resistance [6.7000]
 Maximum Collector hood heater resistance [10.5000]
 Minimum Base hood heater resistance [7.9000]
 Maximum Base hood heater resistance [12.3000]
 Enable Heater Status in Serial Output (Y/N)[Disabled]

Figure 28: Result of FN Command

****Note that some of the above values will vary from the values in your unit.**

3.19 The FR Command – Sensor Reset:

The **FR** command resets the sensor. This is reboot has the same function as a power cycle.

This is a Super User Command that requires a password (see section 3.26 about the Password).

```
sys_reset()
```

Belfort Instrument Model 6400 Visibility Sensor: Version 1.16 (1/4/17)

Copyright 2017 -- Belfort Instrument Company, Baltimore, MD 21224

Initializing...

Figure 29: Result of FR Command

3.20 The FS Command - Span State Calibration:

Span State calibration is used to compensate for changes in the instrument due to time. Span calibration should be performed annually or whenever a transmitter board (PCB) or receiver board (PCB) is changed. This is a Super User Command that requires a password.

This command requires “Super-User” privileges to invoke, which is password protected (see section 3.26 about the Password).

Allow the instrument to operate for 45 to 60 minutes before beginning calibration. Do not reset or disconnect power from instrument before beginning calibration.

1. Attach the RS232 terminal to the Model 6400 Visibility Sensor
2. Carefully inspect the scatter plate for cleanliness and clean as needed with any commercial glass cleaner. Remove smudges, fingerprints, etc. If the Scatter plate has been badly scratched contact the factory before use.

CAUTION

DO NOT USE HARSH SOLVENTS CONTAINING ACETONE, TRICHLORO-ETHANE, METHYL-ETHYL-KETONE, ETC. TO CLEAN THE SCATTER PLATE! Harsh solvents can cause the plastic scatter plate elements to melt and will invalidate the calibration.

3. Carefully hang the scatter plate on the sensor by "hooking" the top bracket over the top of the sensor's cross arm. Center the scatter plate on the cross arm, equal distant from the edge of each hood to the plate.
4. Enter the FN command at the RS-232 terminal and verify that the value of Cal_ExtCo is equal to the value marked on the scatter plate's label.
5. Enter the FS command. When the sensor asks for verification before starting the calibration routine, type the letter Y to accept or ESC (the escape key) to abort. After the SPAN calibration routine has begun, it will run for three minutes allowing the sensor to reach a stable Span state after which it will run for two more minutes making periodic adjustments to the slope as it attempts to minimize the error. At the end of the SPAN calibration routine, the operator will be prompted to accept the new Span factor value. **Note:** If the operator does not respond within three minutes, the sensor aborts the calibration (discarding the value generated) and returns to Normal Run Mode. When the new Span factor value is accepted, it is stored in EEPROM, and it affects all subsequent sensor readings.
6. Remove scatter plate and store in clean safe area.

3.21 The FT Command - Self Test:

The **FT** command performs sensor self-test. It then reports the sensor PASS / FAIL status, the PASS / FAIL status of the RAM, PROM, and EEPROM components, and it reports how long the sensor has been running since last startup.

```
FP 00005 PPPP 11 [0: 4:14:41:54] 96
```

Figure 30: Result of FT Command

```
FP 00005 PPPP 11 [0: 4:14:41:54] 96
^^  ^  ^^^^ ^^      ^  ^
AB  C  DE FG HI      J   K
```

The 12 data fields are identified by letters above, and are described by letter below.

- (A) Sensor identifier, 'F' for FOG
- (B) Sensor PASS / FAIL status
- (C) Sensor serial number
- (D) RAM status (P=PASS or F=FAIL)
- (E) PROM status (P=PASS or F=FAIL)
- (F) EEPROM status (P=PASS or F=FAIL)
- (G) LED status (P=PASS or F=FAIL)
- (H) 1 HOOD HEADER STATUS, 1=ON, 0=OFF
- (I) 1 WINDOW HEADER STATUS, 1=ON, 0=OFF
- (J) Time since last startup in Years, Days, Hours, Minutes, Second's
- (K) Message checksum in Hexadecimal

3.22 The FU Command – Toggle Hood/Electronics Heater:

The **FU** command toggles the state of the Hood and Electronics heater.

If the heaters are already on, the first FU command will turn them off for a period of 1 minute. If the next FU command comes in before the 1 minute time period expires, the heaters will be turned off.

If the heaters are off, the first FU command will turn them on for a period of 1 minute. If the next FU command comes in before the 1 minute time period expires, the heaters will be turned on.

Hood Heater ON.

Hood Heater Off.

Figure 31: Result of FU Command

3.23 The FV Command – Toggle Window Heater:

The **FV** command toggles the state of the Hood and Electronics heater.

If the heaters are already on, the first FV command will turn them off for a period of 1 minute. If the next FV command comes in before the 1 minute time period expires, the heaters will be turned on.

If the heaters are off, the first FV command will turn them on for a period of 1 minute. If the next FV command comes in before the 1 minute time period expires, the heaters will be turned on.

Window Heater ON

Window Heater Off.

Figure 32: Result of FV Command

3.24 The FW Command – Window Heater:

Entering the FW command will cause the sensor to test and report the operational status of the Window heaters. The diagnostics report the window heater current and heater wattage. The Window Heater output message is as follows:

Supply volts: 11.06

Window Heating:

Unit	Amps	Watts	Ohms
Window heat	0.505	5.58	21.9

Figure 33: Window Heater Diagnostics

3.25 The FZ Command - Zero State Calibration:

The **FZ** command performs the zero state calibration. This is performed with the opaque filter in the calibration kit. The ZERO calibration corrects the sensor for changes in offset (this primarily affects high visibility readings). Either calibration routine may be aborted before completion by typing the ESC key.

This command requires “Super-User” privileges to invoke, which is password protected (see section 3.26 about the Password).

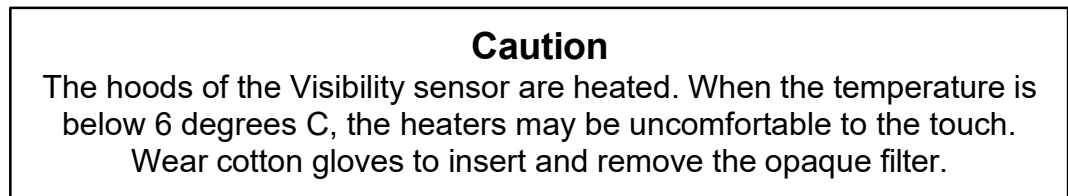

Figure 34: Hood Heater Warning

NOTE

Allow the instrument to operate for 45 to 60 minutes before beginning calibration. Do not reset or disconnect power from instrument before beginning calibration.

1. Connect the model 6400 to an RS232 terminal.
2. Place the opaque filter onto the receiver window (left Hood facing Sensor). Press in firmly to insure that no light will enter the window.
3. Type FZ and flow instructions on the RS232 terminal screen.
4. Type Y to verify that you wish to perform the zero calibration or ESC to escape
5. Wait 3 minutes for the calibration routine to reach zero state.
6. Another 2 minutes is required to produce a new Zero offset value
7. After the calibration is complete, type Y to accept the results. Accepting the values writes the zero value to the EEPROM.

NOTE: If you do not enter Y or N within 3 minutes, the sensor will reset and the old zero value will remain in effect.

8. Remove Opaque filter.

NOTE: Failure to remove the Opaque filter will cause the instrument to report the maximum visibility continuously.

3.26 The Password and Super User Privileges:

The “Super User” privileges allow the operator to modify the configuration and calibration of the Visibility Sensor. Since that affects the way the Sensor works, a Password is needed to become a “Super User”.

The operator will need to communicate with the Sensor using the RS-232 link. The operator may become Super User at any time by typing **Ctrl-V**. That is, press AND HOLD the “**Ctrl**” key, then press the “**V**” key. The Sensor will then ask for a password.

The Password is: **foggy**

The password must be entered in ALL LOWERCASE letters.

Password? -> *****

Password accepted, Operator is now Super User.

Figure 35: Result of typing “Ctrl-V” and correctly entering the Password

Results of typing “Ctrl-V” and correctly entering the Password “foggy”.

To disengage to the super user status type “Ctrl-V” and then hit enter. It should be noted that if the user types “Ctrl-V” and then enters any word other than the password, the super user status is disengaged.

Also, a power cycle or software reset will disengage the super user status.

4.0 Maintenance of the Visibility Sensor:

The visibility sensor requires periodic maintenance. This must be performed to insure proper operation of the instrument.

Met One Instruments suggests that the initial maintenance be conducted 3 months after installation. The time frame should be adjusted depending on the individual sites. Factors may be, but are not limited to, insects at the sites, weather conditions, dust, blowing debris, deposits from water spray, or other factors.

Periodically inspect the sensor for dirt, spider webs, birds' nests or other obstructions. When necessary, carefully clean the protective glass windows in the Receiver and Transmitter with a commercially available glass cleaner.

There are no user serviceable components in the sensor. Should a failure occur, return the sensor to Met One Instruments for repair.

The visibility sensor is fully calibrated at the factory. Field service is available with the use of a calibration kit.

4.1 Maintenance Schedule for the Model 6400 Visibility Sensor:

The Model 6400 Visibility Sensor requires periodic maintenance. A standardized maintenance schedule has been developed based on standard conditions. This schedule should be modified depending on the conditions at the instrument site.

MODEL 6400 Visibility SENSOR MAINTENANCE SCHEDULE

Visibility Sensor

Every 3 Months:.....Inspect and clean optics

Every 3 Months:.....Inspect Cables

Every 1 Year:.....Check Calibration

Figure 36: Maintenance Schedule

4.2 Fuse Location and Replacement:

The Model 6400 contains fuses that are located in the enclosure mounted on the mounting plate. Should an over current condition cause a fuse to open, the enclosure cover can be removed and the fuses tested and replaced with the same type and fuse rating.

****Caution** should be taken when the cover is removed and the electronics PCB is exposed.

The +12v should be disconnected before the fuses are replaced.

F1 Heater Voltage----7 amp
F2 Heater Return----7 amp
F3 +12v Return ---3 amp
F4 12v Return --- 3 amp

Figure 37: Fuses Function and Size

If replacing open fuses do not return the sensor to operation, contact Met One Instruments for support.

5.0 Calibration of the Visibility Sensor:

The Visibility Sensor in the Model 6400 Visibility Sensor may require periodic annual calibration. This is performed with the resident firmware and calibration kit.

FIELD CALIBRATION

Calibration of the sensor can be performed in the field using the 92001 Calibration Kit. For calibration to be performed, the operator must be able to connect an RS-232 terminal (or laptop PC with terminal emulator) to the RS-232 connections of the sensor. The operator must also be able to physically access the sensor in order to attach the calibration components to the sensor during the procedure. The calibration cannot be performed in foggy conditions, or in winds greater than 10Kts. Visibility must be 1 mile or better to perform calibration. High winds cause the scatter plate to move during the calibration which yields incorrect readings and invalidates the calibration. Before beginning calibration, the sensor windows should be inspected and cleaned if there is any noticeable fouling from dirt, etc.

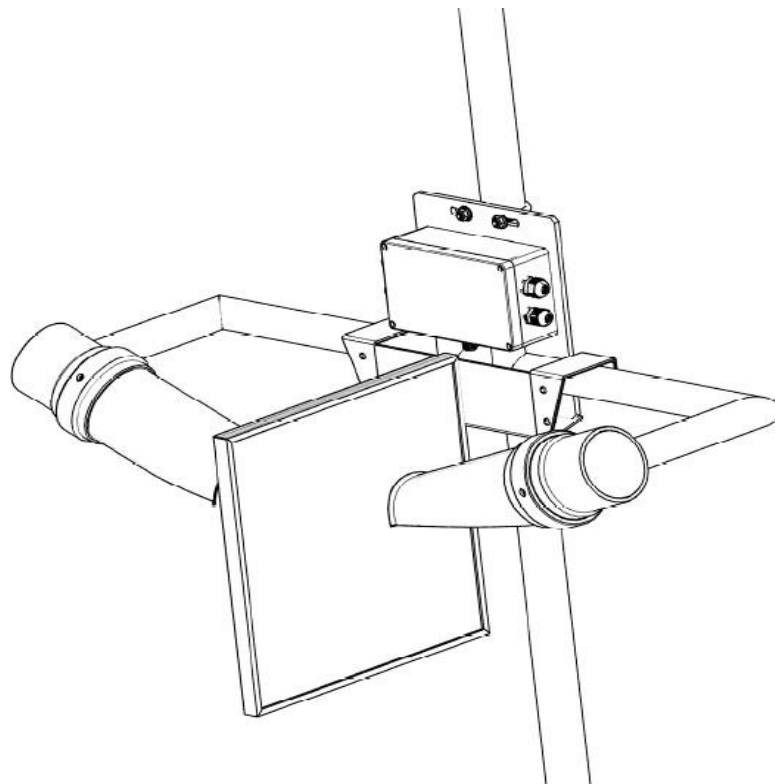

Figure 38: 92001 Calibration Plate mounting

Calibration is performed in two steps, ZERO CALIBRATION and SPAN CALIBRATION.

The ZERO calibration corrects the sensor for changes in offset (this primarily affects high visibility readings). The SPAN calibration corrects the sensor for changes in the slope or gain of the sensor (this primarily affects the low visibility readings). Either calibration routine may be aborted before completion by typing the ESC key.

NOTE

Allow the instrument to operate for 45 to 60 minutes before beginning calibration. Instrument should operate continuously from warm up to calibration.

ZERO CALIBRATION Procedure

To perform the ZERO calibration, push the black foam OPAQUE FILTER up into the Receiver hood. Be certain that the Receiver window is completely blocked, then enter the FZ command at the RS-232 terminal. When the sensor asks for verification before starting the calibration routine, type the letter Y to accept or ESC (the escape key) to abort. After the ZERO calibration routine has begun, it will run for three minutes allowing the sensor to reach a stable Zero state after which it will run for two more minutes taking an average of the zero offset. At the end of the ZERO calibration routine, the operator will be prompted to accept the new Zero offset value. If the operator does not respond within three minutes, the sensor aborts the calibration (discarding the value generated) and returns to Normal Run Mode. When the new Zero offset value is accepted, it is stored in EEPROM, and it affects all subsequent sensor readings. **DO NOT FORGET TO REMOVE THE OPAQUE FILTER AFTER ZERO CAL!** Failure to remove the opaque filter results in a sensor which always reports high visibility regardless of actual conditions.

SPAN CALIBRATION

To perform SPAN calibration, first make certain that the opaque filter is NOT in the receiver hood. Carefully inspect the scatter plate for cleanliness and clean as needed with any commercial glass cleaner. Remove smudges, fingerprints, etc. If the Scatter plate has been badly scratched contact the factory before use. **DO NOT USE HARSH SOLVENTS CONTAINING ACETONE, TRICHLORO-ETHANE, METHYL-ETHYL-KETONE, ETC. TO CLEAN THE SCATTER PLATE!** Harsh solvents can cause the plastic scatter plate elements to melt and will invalidate the calibration.

Carefully hang the scatter plate on the sensor by "hooking" the top bracket over the top of the sensors cross arm. Center the scatter plate on the cross arm, equal distant from the edge of each hood to the plate. Enter the FN command at the RS-232

terminal and verify that the value of Cal_ExtCo is equal to the value marked on the scatter plate's label. Enter the FS command. When the sensor asks for verification before starting the calibration routine, type the letter Y to accept or ESC (the escape key) to abort. After the SPAN calibration routine has begun, it will run for three minutes allowing the sensor to reach a stable Span state after which it will run for two more minutes making periodic adjustments to the slope as it attempts to minimize the error. At the end of the SPAN calibration routine, the operator will be prompted to accept the new Span factor value. If the operator does not respond within three minutes, the sensor aborts the calibration (discarding the value generated) and returns to Normal Run Mode. When the new Span factor value is accepted, it is stored in EEPROM, and it affects all subsequent sensor readings.

DON'T FORGET TO REMOVE THE SCATTER PLATE AND CAREFULLY PUT IT AWAY IN A SAFE PLACE.

6.0 Special Configuration Options:

6.1 Data Ready:

The Model 6400 has the ability to signal to external equipment, that it is about to send data. This Data Ready output is an RS232 Level signal that will toggle from inactive state (-5 to -10vdc) to active state (+5v to +10vdc), a configurable amount of time before its output message is sent.

To enable the Data Ready signal output, the following configuration variable needs to be enabled using the FC command.

Enable RTS Before Transmit (Y/N)? [Disabled] Enter "Y" to enable Data Ready

To configure the time between Data Ready signal and data is output, enter the desired delay into the following variable:

The default value is 4 ms.

RTS Delay before Transmit (in ms) [4] Enter the desired value then press "Enter".

Press ESC key to save variables **AFTER** the last parameter has been changed.

6.2 V7 Poll Response:

The Model 6400 can be configured to respond to a Polled message consisting of the following string of characters:

V7 cr, lf

The string is Upper case V, followed by a 7, followed by a CR and LF with no spaces between any of the characters.

The instrument will respond with the polled visibility value message as follows:

xxxxx cr lf

The message string is xxxxx five digits of visibility clamped to the max visibility value in the configuration file, followed by a CR and LF with no spaces between any of the 3 fields.

To enable the V7 Poll response reported in meters, the following configuration variable needs to be enabled using the FC command.

Enable Polled Mode (Y/N)? [Disabled] Enter "Y" to enable Polled Mode.

The Visibility can be expressed in the following units:

- 0: miles
- 1: Nmiles
- 2: feet
- 3: meters
- 4: kilometers

Enter the desired units by number. [3] Enter "3" for value expressed in meters.

Enable 'V7' Poll Response (Y/N)? [Disabled] Enter "Y" to enable V7 Polled message.

Enable Visibility Clamping (Y/N)? [Disabled] Enter "Y" to enable Visibility Clamping of max value.

Visibility Range Limit (in Mi) [115.1545] Enter the desired Max Visibility value to be reported then press the "Enter" key.

Press ESC key to save the changes **AFTER** the last parameter has been changed.

7.0 Visibility Sensor Configuration Parameter Definitions:

Enable Secondary ID? (Y/N)

Enables the visibility sensor to respond to a secondary address character if in polling mode. Ordinarily, the device only responds to the primary ID character of 'F' as the address character preceding a command character (e.g., FL, F1, etc.). The secondary address is specified by the "Secondary ID" parameter, described immediately below. The default condition is "Secondary ID Disabled". This parameter is useful for multi-drop operation.

Secondary ID

When "Secondary ID Enable" is true, this parameter gives the secondary address character to which the unit will respond (in addition to the primary ID character of 'F'). Valid values are A-E, G-U, and W-Z. When entering this parameter, the decimal ASCII character code of the desired secondary address character must be entered (e.g., 65 for 'A', 66 for 'B', etc.). This parameter is useful for multi-drop operation.

Update_rate (in seconds)

This is the rate at which the instrument will output its Visibility Message. Default value is 1 second.

Enable Polled Mode? (Y/N)

This parameter controls whether or not the unit will automatically output visibility messages (at the specified "update rate"). (It is somewhat of a misnomer, because an "FL" poll is always accepted; this parameter relates only to whether or not the unit will automatically output messages.) If polled mode is enabled, the unit will not automatically output visibility messages. The default is "disabled" (i.e., automatic messages are generated at the "update rate".)

Calibration Zero

This is the calibrated value that the instrument uses to establish the maximum visibility level. This value should not be changed except during a calibration procedure. Calibration requires factory calibrated scatter plate. Default value is 0.0.

Calibration Span

This is the calibrated value that the instrument uses to establish the minimum visibility level. This value should not be changed except during a calibration procedure. Calibration requires factory calibrated scatter plate. Default value is 1.0.

Tx Power Detect Calibration

This is a value obtained during calibration. It is used for detecting LED failure during normal operation, and for adjusting (scaling) the receiver value if enabled. The default value (prior to calibration) is 8000. If the transmit power detect level is less than 1/5 of the "Tx Power Detect Cal" value during normal operation, it is assumed that the LED

has failed and that condition is so indicated in the output message. If "TX Pwr correction" is enabled (see below), this value is used to scale the receiver value, as follows: receiver value is multiplied by "Tx Power Detect Cal" value divided by Tx value.

Tx LED Down-Counter

The "TX LED down count" configures a delay between the toggling of the emitter and the cycle of the A/D converter. Varying the delay is useful for verifying collector electronics performance, but it must be kept at the optimum setting of 60 for normal operation.

Time constant (in seconds)

Used as a filter. Faster =noisy, slower =quieter. This value is the number of seconds over which TX and receiver readings are averaged. Its default value is 57 seconds. If set to less than 1 second, 1 second is assumed. Reported data will be averaged using this time constant, unless "time constant averaging" is disabled (see below).

FOG relay ON delay (in minutes)

FOG relay OFF delay (in minutes)

The idea is to activate the relay (observing "normally on" versus "normally off") when visibility deteriorates below a certain point (i.e., the "fog threshold" minus one half of the "fog thres var"), but only after it's been at this point or less for the "relay on delay" time. Then, when conditions improve to at least the "fog threshold" value PLUS one half of the "fog thres var", the relay is de-activated after a delay of at least the "relay off delay" time. The default for the "relay on time" is 10 minutes. The default for the "relay off time" is 5 minutes.

FOG_threshold (Vis in Mi)

FOG_thres_var (Vis in Mi)

Once each second, the current visibility is checked. Assuming the relay is not active and the visibility is equal to or greater than the configured "fog threshold" minus one half of the configured "fog thres var", nothing happens. Once the visibility goes below that point, a timer is started with the number of seconds configured in the "Fog relay on delay" time. If visibility remains below the threshold minus one half of the "thres var" for the total "on delay" time, then the relay is activated. Once visibility goes equal to or above the "threshold" minus half of the "thres var", a timer is started equal to the number of seconds configured in the "Fog relay off delay" time. When visibility improves to the point of being greater than the "fog threshold" PLUS one half of the "thres var", the relay is de-activated, but only if the "off delay" time has expired, else it waits until the "off delay time" expires as long as visibility remains above or equal to the "threshold" PLUS one half of the "thres var".

The idea is to activate the relay (observing "normally on" versus "normally off") when visibility deteriorates below a certain point (i.e., the "fog threshold" minus one half of the "fog thres var"), but only after it's been at this point or less for the "relay on delay" time. Then, when conditions improve to at least the "fog threshold" value PLUS one

half of the "fog thres var", the relay is de-activated after a delay of at least the "relay off delay" time.

The default for FOG_threshold is 10 miles. The default for FOG_thres_var is 1 mile.

Sensor Serial number

Instrument serial number set at time of manufacture.

Sensor Baud rate

This is the communication baud rate that the instrument will use to report to the monitoring device. This is the only communications parameter value that can be changed. Valid selections are 150, 300, 1200, 2400, 4800, 9600, 19200, and 38400 baud.

Vis units [miles,km]

This gives the unit of distance measurement for the instrument's measured visibility. The possibilities are: 0 for "miles", 1 for "nautical miles", 2 for "feet", 3 for "meters", and 4 for "kilometers". The default value is 0 (miles).

Cal_ExtCo

This is the Extinction Coefficient value of the Scatter plate used during the calibrated procedure. This value should be re-entered from the scatter plate at the time of every calibration. The default value is 1208.9875.

Relay Normally ON? (Y/N)

This value determines the idle state of the Fog Alarm Relay. If "Y" (enabled) then the idle state of the relay is energized and the normally open contacts are closed. If "N" (disabled) then the idle state of the relay is de-energized and the normally open contacts are open. The default setting is "N" (disabled).

Enable Verbose Mode (Y/N)

"Y" enables the unit to report when it automatically initiates a self-test, and the results of the self-test. Ordinarily, automatic self-tests are silent. The default setting is "N" (disabled).

Time Constant Averaging (Y/N)

"N" will disable Time Constant Averaging. Reported values will then be non-averaged values (i.e., instantaneous readings). This setting is used for diagnostic troubleshooting purposes only. The customer should not change this value to "Disabled". The default setting is "Y" (enabled).

Visibility Clamping? (Y/N)

If enabled, the maximum reported Visibility Range will be clamped to not exceed the value saved in the "Visibility Range Limit" parameter (see below). The default setting is "N" (disabled).

Visibility Range Limit

This parameter defines the maximum visibility reported when “Visibility Clamping” (see above) is enabled. It applies only when “Visibility Clamping” is enabled. The default value is 100 nautical miles (approximately 115 statute miles).

TX Pwr correction? (Y/N)

If enabled, the receiver value is scaled by a formula involving the Tx power and Tx calibration value, as follows: Receiver value is multiplied by “Tx Power Detect Cal” value divided by Tx value. See related parameter “Tx Pwr Detect Cal”, described above. The default condition for this parameter is “Y” (enabled).

Enable Short Message (Y/N)

If enabled, the unit reports less data in its visibility report message. Only the following items are reported when this parameter is enabled: system status, serial number, relay status, visibility, visibility units, and extinction coefficient. The default condition for this parameter is “N” (disabled).

WaveLenCorFactor

WaveLenCorExp

These two parameters work in tandem to provide a wavelength correction factor and exponent to be applied to the measured extinction coefficient. The default for both parameters is 0.0, and both must be in the range of -100.0 to 100.0, inclusive. No correction is done if the wavelength correction factor is 0.0 (thus, by default, no correction is applied). When the wavelength correction factor is other than 0.0, the measured extinction coefficient is adjusted per the following formula:

$$\text{ExtCo} = \text{ExtCo} + (\text{wavelen_cor_factor} * (\text{pow}(\text{ExtCo}, \text{wavelen_cor_exp})))$$

(the “pow()” function raises its first operand (ExtCo) to the power of the second operand (wavelen_cor_exp).)

Enable 6000 Response Format (Y/N)

This parameter enables or disables 6000 emulation mode. When enabled, the output message will be the Model 6000 output message.

Enable 6230A Emulation (Y/N)

This parameter enables or disables 6230A emulation mode. When enabled, certain 6230A commands will be processed. Similar to the 6000, 6230A commands consist of two characters: an address character and a command character. For the 6230A, the address character is always a ‘V’ (like the ‘F’ address character for the 6000). The default state of this parameter is “N” (disabled).

6230A Emulation Message Type (Y/N)

This parameter applies only if 6230A emulation mode is enabled (see above), and defines the type of visibility message that will be output. Valid values are 0 (for

“normal”), 1 (for “ESAWS”), 2 (for “SAMOS”), 3 (for “Terminal”), 4 (for “Marine”), and 5 (for “AF2000”). The default value is 0 (“normal”).

BMO Type ID

This parameter defines the “type ID” data that will be output in a 6230A “Marine” format message. It applies only if 6230A emulation mode is enabled (see above), and if the 6230A message type is set to 4 (“Marine”). Values are limited to 0-99; the default is 0.

Enable RTS Before Transmit (Y/N)

The Model 6400 has the ability to signal to external equipment, that it is about to send data. This Data Ready output is an RS232 Level signal that will toggle from inactive state (-5 to -10vdc) to active state (+5v to +10vdc), a configurable amount of time before its output message is sent.

To enable the Data Ready signal output, the configuration variable needs to be enabled using the FC command.

RTS Delay Before Transmit (in ms)

To configure the time between Data Ready signal and data is output, enter the desired delay into the variable RTS Delay before Transmit (in ms). The default value is 4 ms.

Enable 'V7' Poll Response (Y/N)

The Model 6400 can be configured to respond to a Polled message consisting of the following string of characters “V7 cr, lf”. The string is Upper case V, followed by a 7, followed by a CR and LF with no spaces between any of the characters.

The instrument will respond with the polled visibility value message “xxxxx cr lf”. The message string is xxxxx five digits of visibility clamped to the max visibility value in the configuration file, followed by a CR and LF with no spaces between any of the 3 fields.

To enable the V7 Poll response reported in meters, the following configuration variable needs to be enabled using the FC command.

Set RS232 (Y/N)

This parameter selects RS-232 mode or RS-485 (RS-422) mode on the serial port. “Y” sets RS-232 mode, and “N” sets RS-485 (RS-422) mode. The default is RS-232.

Enter Y to Enable ALS (Y/N)

If an ALS is attached, this parameter will enable the visibility sensor to read the ALS value and report that value.

Enter Y to append ALS message to end of the 6400 output message (Y/N)

If an ALS is attached, this parameter will enable the visibility sensor to append the ALS value to the end of the visibility output message.

Enable Analog output? (Y/N)

This is an “Enable” or “Disable” control of the hardware analog output. Default is “Enabled”. The hardware analog output level will not be updated if this is disabled.

Analog output in Visibility?

This parameter controls whether the “analog output limit” (see below) is expressed in terms of the extinction coefficient (i.e., inverse kilometers), or in the currently-selected units of visibility. It applies only if the analog output is enabled (see above). If enabled, the “analog output limit” is taken to be in the currently-selected units of visibility. The default is “enabled” (i.e., the “analog output limit” is in terms of visibility).

Analog out limit, Vis in Mi

This parameter gives the upper-limit value of the analog output. It applies only if the analog output is enabled (see above). The value is expressed in the currently-selected units of visibility if the “analog output in visibility” parameter is enabled (see above), and in units of inverse kilometers (i.e., relative to the extinction coefficient) otherwise. The analog output is clamped to this value if the measured visibility or extinction coefficient (as appropriate) exceeds the specified value. The default for this parameter is 10 miles.

Output voltage range

This parameter sets the output voltage range. Valid values are 1, 5, and 10 volts. The default is 10 volts.

Report Ambient Temp (Y/N)

This parameter when enabled will cause the sensor measured ambient temperature to be added to the output message string.

Temperature Units in degrees C (Y/N)

This parameter will change the temperature to be reported in degrees C. All reported temperature will be in degrees C in all commands.

Hood Heater Set Point in degrees F [43.0000]

This parameter is the temperature for the Hood Heaters to turn on if the ambient temperature is below the set point.

Window Heater Set Point in degrees F [130.0000]

This parameter is the temperature for the Window Heaters to turn on if the ambient temperature is below the set point. The default is for the window heaters to be on all the time.

Enable Heater Status in Serial Output (Y/N)[Disabled]

This parameter if enabled will cause the Heater Status to be added to the end of the output message string.

Minimum total window heater resistance [15.4000]

Maximum total window heater resistance [24.0000]

These two parameters are the lower and upper window heater resistance limits for the testing of the window heaters.

Minimum Collector hood heater resistance [6.7000]

Maximum Collector hood heater resistance [10.5000]

These two parameters are the lower and upper collector side hood heater resistance limits for the testing of the collector hood heater.

Minimum Base hood heater resistance [7.9000]

Maximum Base hood heater resistance [12.3000]

These two parameters are the lower and upper emitter side hood heater resistance limits for the testing of the emitter hood heater.

8.0 Manufacturers Information:

CONTACT

Met One Instruments
200 NE Greenfield Rd.
Grants Pass, Oregon
97526 USA
Phone: (541) 471-7111
www.metone.com
service.moi@acoem.com